

# Energy Research Program

## Public Report

### Program Strategy:

Climate and Energy Funds

### Program Management:

Austrian Research Promotion Agency

## Final Report



August 29, 2022

# IEA HEV Task 30 – Assessment of Environmental Effects of Electric Vehicles

FFG project number: 865135

# e!Mission.at – 4 call for proposals

National Climate and Energy Fund - Administered by the Austrian Research Promotion Agency (FFG)



**Acknowledgments:** *The Management of the IEA HEV Task 30 “Assessment of Environmental Effects of Electric Vehicles” was financed by the common fund of the IEA Technology Cooperation Programme (TCP) on Hybrid and Electric Vehicles (HEV) within the framework of the International Energy Agency (IEA).*

*We want to thank the partners in Task 30 for their contributions and the successful cooperation*

- *Pierre-Olivier Roy, CIRAIG (CA)*
- *Simone Ehrenberger, DLR (DE)*
- *Gabriela Benveniste Pérez, Víctor José Ferreira Ferreira, IREC (ES)*
- *Ock Taeck Lim, Ulsam University (KR)*
- *Tugce Yuksel, Sabanci Universitesi (TR)*
- *Jarod Kelly, Amgad Elgowainy, ARGONNE (US)*

Call	4. Ausschreibung Energieforschungsprogramm
Project start	01/01/2018
Project end	31/06/2022
Project duration	54 month
Institution	JOANNEUM RESEARCH Forschungsgesellschaft mbH (LIF.02-18.AF.002-01 IEA Task 30 Environment)
Contact person	Dr. Gerfried Jungmeier
Adress	Waagner-Biro-Strasse 100
Phone	+43 316 876 7630
Fax	+43 316 876 9 7630
E-mail	gerfried.jungmeier@joanneum.at
Webpage	<a href="http://www.joanneum.at">www.joanneum.at</a> <a href="https://ieahev.org/tasks/30/">https://ieahev.org/tasks/30/</a>

# IEA HEV Task 30

–

# Assessment of Environmental Effects of Electric Vehicles

**Authors:**

Gerfried Jungmeier, Sebastian Seebauer, Maria Hingsamer, Martin Beermann, Christian Aichberger



## Content

### Summary

### Zusammenfassung

1	Aim of the activity.....	15
1.1	Motivation.....	15
1.2	Goal and Scope .....	15
1.3	Approach.....	16
1.4	Cooperations and Partners.....	17
1.4.1	IEA HEV TCP.....	17
1.4.2	Membership to the HEV TCP .....	18
1.4.3	Governance and Management .....	18
1.4.4	Tasks .....	19
1.4.5	Partners in Task 30 .....	20
1.4.6	National Project Advisory Board.....	21
2	Results.....	22
2.1	Overview .....	22
2.2	Expert Workshop on Water Issues .....	22
2.2.1	Introduction .....	22
2.2.2	Results.....	23
2.2.2.1	Overview .....	23
2.2.2.2	Main Drivers .....	23
2.2.2.3	Water Inventory.....	24
2.2.2.4	Most Relevant Water Issues for LCA of EV and ICE .....	24
2.2.2.5	Water Footprint .....	24
2.2.2.6	Water Issues in Electricity Production .....	25
2.2.2.7	Water Issues in Value Chain of EVs and ICE .....	25
2.2.2.8	Research Questions on Water Issues & EVs.....	26
2.2.2.9	Possible Activities of IEA HEV Task 30 .....	26
2.3	Expert Workshop on Effects on Air.....	27
2.3.1	Introduction .....	27

2.3.2	Results .....	27
2.3.3	Identified Key issues .....	30
2.3.4	Future Developments on LCA of EVs .....	32
2.4	Expert Workshop on Resources, Waste and Land Use (incl. LCA Autonomous Vehicles).....	32
2.4.1	Introduction .....	32
2.4.2	Results on Resources and Waste .....	33
2.4.2.1	LCA of Battery Production .....	33
2.4.2.2	LCA of Battery Recycling .....	34
2.4.2.3	LCA of Electric Motor Recycling (Magnets) .....	34
2.4.2.4	LCA of Power Electronics Recycling .....	34
2.4.2.5	Results on Land Use .....	35
2.4.2.6	Results on Autonomous Vehicles .....	37
2.5	Expert Workshop on Impact Assessment.....	38
2.5.1	Introduction .....	38
2.5.2	Impact Assessment .....	38
2.5.3	Mid-point Indicators .....	40
2.5.4	End-point Indicators .....	42
2.5.5	Assessment Methodologies for Local and Regional Impacts.....	42
2.5.5.1	Human Toxicity Potential.....	42
2.5.5.2	Abiotic Depletion Potential.....	43
2.5.5.3	Water .....	43
2.5.5.4	Biodiversity.....	44
2.5.6	Selection of Indicators in LCA for EVs and ICEs .....	45
2.5.7	Framework .....	45
2.5.8	Current Minimum Requirements.....	46
2.5.9	Future Advanced Requirements.....	47
2.5.10	Conclusion and Outlook .....	47
2.6	Rebound Effects of EVs and Possible Implication on LCA.....	48
2.6.1	Introduction .....	48
2.6.2	Types and Dynamics of Rebound.....	48

2.6.3	Magnitude of Rebound Effects .....	50
2.6.4	LCA of EVs and Rebound Effects.....	52
2.6.5	Recommendations .....	53
2.6.6	References.....	54
2.7	Evaluation of the Environmental Benefits of the Global EV-Fleet in 38 Countries.....	58
2.7.1	Goal and Scope .....	58
2.7.2	Basic Data and Assumptions.....	60
2.7.3	Results .....	62
2.7.4	Conclusions.....	70
2.7.5	References.....	70
2.8	Issues on Dynamic LCA of Vehicle Fleets .....	71
2.8.1	Introduction .....	71
2.8.2	Methodological Aspects .....	71
2.8.3	LCA of Supplying Additional Renewable Electricity – Example Austria.....	73
2.8.4	GHG Emissions of BEV Introduction in Austria.....	75
2.8.5	Scenarios for a Climate Neutral Passenger Vehicle Fleet in Austria 2040/2050 .....	77
2.9	Dissemination Activities.....	81
3	Conclusions .....	84
3.1	Lessons Learnt.....	84
3.1.1	Overview .....	84
3.1.2	Methodology for Environmental Assessment: LCA not WtW .....	84
3.1.3	System Boundary .....	85
3.1.4	Systematic of Transportation Systems .....	86
3.1.5	Main Factors Influencing LCA Results.....	87
3.1.6	Possible Impacts and Impact Assessment Methodologies.....	88
3.1.7	Minimum Requirement on Impact Assessment.....	89
3.1.8	Main Water Issues in LCA of ICE and EV.....	90
3.1.9	Recommendations for LCA of BEV, PHEV and ICE .....	90
3.1.10	Potential Rebound Effects of EVs.....	92
3.1.11	Dynamic LCA and Vehicle Fleets for Climate Neutrality 2050 .....	93

3.2 Outlook.....93

**Annexes**

1. Expert Workshop on Water Issues
2. Expert Workshop on Effects on Air
3. Expert Workshop on Resources, Waste and Land Use (incl. LCA Autonomous Vehicles)
4. Expert Workshop on Impact Assessment

**List of Figures**

Figure 1: System boundaries for life cycle assessment of EVs ..... 15

Figure 2: Approach of Task 30 ..... 17

Figure 3: Countries and institutions in Task 30 ..... 21

Figure 4: Main water issues in LCA of ICE and EV ..... 26

Figure 5: Estimated ranges of GHG Emissions from battery system per km ..... 30

Figure 6: Cradle-to-Gate environmental impacts of 1 kWh NMC111 battery ..... 33

Figure 7: Mind map on “Land Use – Resources – Waste in LCA of EVs” ..... 36

Figure 8: From Inventory Analysis to the Impact Assessment in LCA ..... 39

Figure 9: System boundaries between direct, indirect, and economy-wide rebound. .... 49

Figure 10: LCA system boundary ..... 59

Figure 11: Vehicle fleet worldwide 2014 – 2018 [7, 8]..... 60

Figure 12: Country Factsheets on estimated environmental impacts of current EV-fleet – Example Austria..... 64

Figure 13: Estimated range of GHG emissions of electricity at charging point in IEA HEV countries in 2018 ..... 65

Figure 14: Estimated range of GHG emissions of electricity at charging point in Non IEA HEV countries in 2018 ..... 65

Figure 15: Estimated range of GHG emissions reduction of EVs substituting ICE vehicles in IEA HEV countries in 2018 ..... 66

Figure 16: Estimated range of GHG emissions reduction of EVs substituting ICE vehicles in Non IEA HEV countries ..... 67

Figure 17: Estimated range of increasing GHG reduction of EVs substituting ICE vehicles globally (2014 – 2018) ..... 68

Figure 18: Estimated range of change in cumulative primary energy consumption of EVs substituting ICE vehicles globally (2014 – 2018) ..... 68

Figure 19: Timing of cumulated environmental effects of three systems with the same lifetime ..... 72

Figure 20: Timing of environmental effects of a BEV using renewable electricity substituting an ICE vehicle ..... 73

Figure 21: Renewable electricity generation in Austria (references are given in working document)..... 74

Figure 22: GHG emissions of renewable electricity generation in Austria ..... 75

Figure 23: Change of GHG emissions of BEV fleet substituting ICE fleets in Austria ..... 77

Figure 24: Development of passenger vehicle fleet for climate neutrality 2050 .....79

Figure 25: Passenger vehicle energy consumption .....79

Figure 26: LCA based GHG-emissions of passenger vehicle fleet for climate neutrality 2050 .....80

Figure 27: LCA based total primary energy demand of passenger vehicle fleet for climate neutrality 2050 .....80

Figure 28: Cumulated results 2020 – 2050: BEV and e-Fuel .....81

Figure 29: Lesson learnt #1: LCA is the only methodology for Environmental Assessment .....85

Figure 30: Lesson learnt #2: System boundaries .....86

Figure 31: Lesson learnt #3: Systematic of transportation systems .....87

Figure 32: Lesson learnt #5: GHG emissions and primary energy demand as minimum requirement in Impact assessment .....90

Figure 33: Lesson learnt #8: Main global impacts and documentation requirements .....92

**List of Tables**

Table 1: Direct rebound in personal automotive transport.....51

Table 2: Main vehicle data.....61

Table 3: Environmental data of vehicles .....61

Table 4: Equivalent factors of environmental impacts .....61

Table 5: Estimated change of environmental effects of global EV fleet in 2018 .....69

### Summary

Electric vehicles (EVs) have the potential to substitute conventional vehicles to contribute to the sustainable development of the transportation sector worldwide, for example by reducing greenhouse gas (GHG) emissions, fossil energy consumption and particulate emissions. There is international consensus that the improvement of the sustainability of EVs can only be analysed based on life cycle assessment (LCA), which includes the production, the operation, and the end of life (EoL) management of the vehicles and the fuel cycle. All environmental impacts must include the whole value chain and - if relevant - interactions from recycling in the dismantling phase to the production phase, if recycled material is used to produce new vehicles.

The aim of Task 30 (2016 – 2022) was to analyse and assess environmental effects of EVs on water, land use, resources and air based on LCA in a cooperation of the participating countries in the International Energy Agency (IEA) in the Technology Program (TCP) on Hybrid and Electric Vehicles (HEV). With an eye on the three phases of LCA, such as production, operation and dismantling of EVs, various environmental effects of EVs on water, land use, resources and air, among others, are analysed and assessed. Thereby a strong accent is put on the comparison of environmental effects between pure battery EVs (BEVs) and plug-in hybrids (PHEVs) on one hand and conventional internal combustion engine (ICE) vehicles using gasoline and diesel on the other side.

The following partners in 7 countries cooperate in Task 30 with their own financing: Spain: IREC – Catalonia Institute for Energy Research, Canada: CIRAIK - International Reference Centre for the Life Cycle of Products, Processes and Services, Germany: DLR - Deutsches Zentrum für Luft- und Raumfahrt (German Aerospace Center), Republic of Korea: Ulsan University, Turkey: Sabanci Universitesi, USA: Argonne and Austria: JOANNEUM RESEARCH. Beside global warming and primary energy consumption also other impacts like water issues, land use, resource consumption, local particulate matter (PM) and NO<sub>x</sub>-emissions are addressed by life cycle based comparisons. Task 30 has further developed methods, compiled basic data for LCA, discussed case studies and documented the results in detail and made them available.

The results are:

- Expert Workshop on Water Issues
- Expert Workshop on Effects on Air
- Expert Workshop on Resources, Waste and Land Use (incl. LCA Autonomous Vehicles)
- Expert Workshop on Impact Assessment
- Rebound Effects of Electric Vehicles and Possible Implication on Environmental Effects in LCA
- Evaluation of the Environmental Benefits of the Global EV-Fleet in 38 Countries
- Issues on Dynamic LCA of Vehicle Fleets and
- Dissemination activities

The 10 lessons learnt summarize the results:

1. Environmental effects can only be analysed based on Life Cycle Assessment (LCA), other methods like Well-to-Wheel (WtW) are not adequate as all stages in the lifetime of a transportation system must be covered.
2. The system boundaries in LCA must cover all phases in the lifetime of a vehicles and the supply of energy: production, operation and end of life.
3. The considered transportation systems must be characterised by the type of vehicle, propulsion system, fuel/energy carrier, type of primary energy, state of technology and country/region.
4. The main factors influencing the LCA based environmental effects of EVs are: source of electricity generation and its future development up to 2030/2050, lifetime mileage, energy consumption of vehicle (incl. heating,

cooling, auxiliaries), electric driving share for PHEV, battery covering production (country, production capacity, source of electricity), battery capacity and end of life (material recycling or reuse in 2<sup>nd</sup> life).

5. In LCA, the way from Inventory Analysis to Impact Assessment is via mid- and end-point indicators. With regard to the geographical scope of the different impacts, the mid-point indicators are grouped for global, regional and local impacts, where global impacts are most relevant in LCA.
6. The minimum requirement in the impact assessment to compare different vehicles are the GHG emissions in CO<sub>2</sub>-equivalent with its share of CO<sub>2</sub>, CH<sub>4</sub> and N<sub>2</sub>O and primary energy demand with its share of fossil and renewable energy.
7. The main water issues in LCA are for ICE (incl. blending of biofuels) the fossil fuel extraction and refining, cultivation of feedstock for biofuels, and the vehicle production. For EVs the electricity generation (e.g. thermal open/closed cycle, hydropower), battery and vehicle production.
8. The main global impacts to be addressed (in future) are climate change, primary energy use (fossil and renewable), resource use minerals and metals, water footprint (inventory level) and land use (inventory level). The results should be documented and communicated for the total life cycle but also for the three main phases in LCA.
9. The possible rebound effect can be considered in LCA by the definition of the functional unit and the substitution rate. In reflecting possible rebound effects in comparing the environmental effects of EVs with conventional ICE vehicles the following issues have to be considered: number of substituted ICE vehicles, substituted other transportation modes, e.g. public transport and walking, different annual mileage, vehicle lifetime, and driving distance with one charging or refill.
10. Issues on dynamic LCA, e.g. development of annual environmental effects, become relevant for the rapidly increasing of EV-fleets combined with the additional generation of renewable electricity. The timing of environmental effects is relevant in the three lifecycle phases, the increasing supply of renewable electricity, and substitution effects and timing of environmental effects of EVs substituting for ICE vehicles. The environmental effects based on LCA should be shown over time.



## Zusammenfassung

Elektrische Fahrzeuge haben das Potential konventionelle Fahrzeuge zu ersetzen und so zur nachhaltigen Entwicklung des weltweiten Transportsektors beizutragen, z.B. Reduktion der Treibhausgas-Emissionen, fossilem Energiebedarf und Staub-Emissionen. Es besteht internationaler Konsens, dass die Umweltauswirkungen bzw. deren Veränderungen durch Elektrofahrzeuge nur im Rahmen von Lebenszyklusanalysen (LCA – Life Cycle Assessment) untersucht und bewertet werden können, indem alle drei Phasen im Lebenszyklus von der Herstellung, dem Betrieb und der Entsorgung bzw. Verwertung berücksichtigt werden. Alle Umwelteffekte müssen entlang der gesamten Wertschöpfungskette untersucht werden, sowie auch die Zusammenhänge von Sekundärrohstoffen aus dem Recycling in der Produktion.

Ziel der Task 30 (2016 – 2022) war es, die Umweltauswirkungen von Elektrofahrzeugen auf Wasser, Landnutzung, Rohstoffe und Luft auf Basis von Lebenszyklusanalysen in einer internationalen Kooperation mit Partnerländern in der Internationalen Energie Agentur (IEA) im Technology Program (TCP) zu Hybrid and Electric Vehicles (HEV) zu analysieren und zu bewerten. Mit dem Blick auf die drei Phasen im Lebenszyklus von Fahrzeugen – Produktion, Betrieb und Verwertung – wurden unterschiedliche Umweltauswirkungen von Elektrofahrzeugen auf Wasser, Landnutzung, Rohstoffe und Luft untersucht und bewertet. Hierbei wurde ein Schwerpunkt auf PKW gelegt, die mit batterie-elektrischem Antrieb, konventionellem Verbrennungskraftmotor (VKM) sowie der Kombination als Plug-In-Hybrid (PHEV) betrieben werden.

Die folgenden Partner aus 7 Ländern haben in der Task 30 zusammengearbeitet mit deren eigenen nationalen Finanzierungen: Spanien: IREC – Catalonia Institute for Energy Research, Canada: CIRAI – International Reference Centre for the Life Cycle of Products, Processes and Services, Deutschland: DLR - Deutsches Zentrum für Luft- und Raumfahrt, Südkorea: Ulsan University, Türkei: Sabanci Universitesi, USA: Argonne und Österreich: JOANNEUM RESEARCH. Neben den Treibhausgas-Emissionen und dem Primärenergiebedarf wurden auch andere Umweltauswirkungen auf Wasser, Luft, Rohstoffbedarf, lokale Schadstoffemissionen (z.B. NO<sub>x</sub>, PM) untersucht. Die Task 30 hat dabei Methoden weiterentwickelt, Grunddaten für die LCA erarbeitet sowie Fallbeispiele diskutiert und die Ergebnisse ausführlich dokumentiert und verfügbar gemacht.

Die Ergebnisse sind:

- Experten-Workshop zu Wasser-Aspekten
- Experten-Workshop zu Auswirkungen auf die Luft
- Experten-Workshop zu Rohstoffen, Abfällen und Reststoffen sowie Landnutzung (inkl. LCA von autonomen Fahrzeugen)
- Experten-Workshop zu Umwelt-Bewertungsmethoden
- Rebound Effekte von Elektrofahrzeugen und mögliche Auswirkungen auf die Umweltbewertung mit LCA
- Evaluierung der Umweltauswirkungen der globalen Flotte an Elektrofahrzeugen in 38 Ländern
- Methoden und Anwendungen der dynamischen LCA auf Fahrzeugflotten und
- Verbreitungs- und Vernetzungs-Aktivitäten.

Die folgenden Lessons Learnt fassen die Ergebnisse zusammen:

1. Umweltauswirkungen können nur auf Basis von Lebenszyklusanalysen untersucht und bewertet werden. Andere Methoden, wie z.B. Well-to-Wheel (WtW) sind hierzu nicht geeignet, da wesentliche Teile im Lebenszyklus nicht erfasst werden.
2. Die Systemgrenzen der LCA müssen alle Phasen im Lebenszyklus eines Fahrzeuges umfassen, die Fahrzeugherstellung, den Betrieb mit der Bereitstellung der Energie sowie die Verwertung bzw. Entsorgung.

3. Die untersuchten Transportsysteme müssen eindeutig festgelegt und beschrieben werden, wobei die Fahrzeugkategorie, das Antriebssystem, der Energieträger, der Primärenergieträger, Stand der Technik sowie das Land/Region angeführt werden müssen.
4. Die wesentlichen Parameter, die die Umweltauswirkungen von Elektro-Fahrzeugen beeinflussen, sind: Art der Stromerzeugung und dessen Entwicklung bis 2030/2050, Lebensdauer bzw. gefahrene Kilometer im Lebenszyklus, Energiebedarf des Fahrzeugbetriebes, Anteil an rein elektrischer Betriebsweise bei PHEV, Batterieproduktion (inkl. Produktionsland), Batterie-Kapazität sowie Reuse bzw. Recycling von Batterien.
5. In der LCA erfolgt die Bewertung von den Umweltauswirkungen ausgehend von der Sachbilanz zu Zwischen- bzw. Endpunkt-Indikatoren. Wenn die geografischen Orte der Umweltauswirkungen berücksichtigt werden, können die Mid-Point-Indikatoren in globale, regionale und lokale Umweltauswirkungen unterteilt werden, wobei die globalen Umweltauswirkungen für die Methode der LCA am wichtigsten sind.
6. Die Mindest-Anforderung bei der Umweltbewertung von Fahrzeugen ist es, im Rahmen der LCA die Treibhausgas-Emissionen mit den Anteilen an CO<sub>2</sub>, CH<sub>4</sub> und N<sub>2</sub>O und den Primärenergiebedarf mit den Anteilen an fossiler und erneuerbarer Energie zu ermitteln.
7. Die möglichen wesentlichen Auswirkungen auf das Wasser von konventionellen VKW (inkl. der Beimischung von Biotreibstoffen) sind die Förderung und Raffination von Rohöl, der landwirtschaftliche Rohstoffanbau und die Fahrzeug-Produktion; bei Elektro-Fahrzeugen die Stromerzeugung (z.B. Wasserkraft, thermische Kraftwerke), sowie die Batterie- und Fahrzeug-Produktion.
8. Die wesentlichen globalen Umweltauswirkungen, die (zukünftig) in LCAs von Elektro-Fahrzeugen untersucht werden müssen, sind: Treibhausgas-Emissionen, Primärenergiebedarf, Bedarf an mineralischen und metallischen Rohstoffen, Wasser-Fußabdruck (Sachbilanz) und Landnutzung (Sachbilanz). Die Ergebnisse zu diesen globalen Umweltauswirkungen müssen insgesamt, aber auch nach den 3 Hauptphasen der LCA dokumentiert und kommuniziert werden.
9. Mögliche Rebound Effekte können in der LCA bei der Festlegung der funktionalen Einheit und bei der Substitutionsrate berücksichtigt werden. Die Analyse der möglichen Rebound-Effekte hat gezeigt, dass beim Vergleich von Elektro- mit konventionellen VKM-Fahrzeugen die folgenden Aspekte erfasst werden sollen: Anzahl der ersetzten VKM-Fahrzeuge, Ersatz anderer Transportsysteme wie öffentlicher Verkehr und zu Fuß gehen, unterschiedliche Jahreskilometer, Lebensdauer der Fahrzeuge (inkl. Batterie) sowie Reichweite pro Tankfüllung bzw. Ladung.
10. Die Aspekte der dynamischen LCA, z.B. Entwicklung der jährlichen Umweltauswirkungen, werden relevant bei der stark steigenden Anzahl an Elektro-Fahrzeugen und dem damit verbundenen stark steigenden zusätzlichen Bedarf an erneuerbarem Strom. Der Zeitverlauf der Umweltauswirkungen ist relevant für die drei Phasen im Lebenszyklus, die zusätzliche Stromerzeugung sowie die Substitutionseffekte und den zeitlichen Verlauf der Umweltveränderungen bei Ersatz von VKM- und Elektro-Fahrzeuge. The Umweltauswirkungen aus der LCA sollten also im zeitlichen Verlauf dargestellt werden.

# 1 Aim of the activity

This chapter covers the motivation, the goal and scope, the approach and the cooperations and partners

## 1.1 Motivation

Electric vehicles (EVs) have the potential to substitute conventional vehicles to contribute to the sustainable development of the transportation sector worldwide, for example in the reduction of greenhouse gas (GHG) emissions, fossil energy consumption and particulate emissions. There is international consensus that the improvement of the sustainability of EVs can only be analysed based on life cycle assessment (LCA), which includes the production, the operation, and the end of life (EoL) management of the vehicles and the fuel cycle (Figure 1). All environmental impacts must include the whole value chain and - if relevant - interactions from recycling in the dismantling phase to the production phase, if recycled material is used to produce new vehicles.

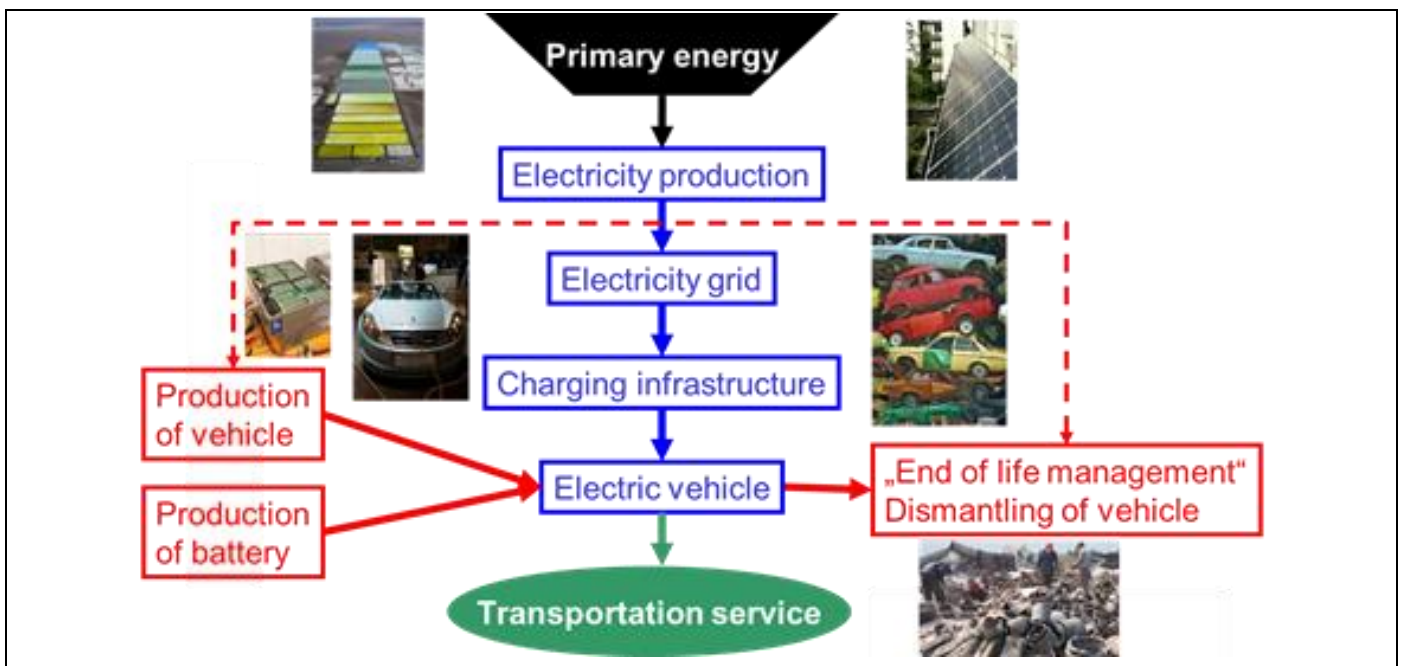

Figure 1: System boundaries for life cycle assessment of EVs

## 1.2 Goal and Scope

The aim of Task 30 (2016 – 2022) was to analyse and assess environmental effects of EVs on water, land use, resources and air based on LCA in a cooperation of the participating countries in the International Energy Agency (IEA) TCP.

Task 30 was using the results of the completed Task 19 “Life Cycle Assessment of Electric Vehicles” (2011 – 2015, [www.ieahev.org/tasks/task-19-life-cycle-assessment-of-evs/](http://www.ieahev.org/tasks/task-19-life-cycle-assessment-of-evs/), led by JOANNEUM RESEARCH) as a foundation to subsequently examine the environmental effects – benefits and impacts - of vehicles with an electric drivetrain (EVs), based on LCA.

With an eye on the three phases of LCA, such as production, operation and dismantling of EVs, various environmental effects of EVs on water, land use, resources and air, among others, are analysed and assessed. Thereby a strong accent is put on the comparison of environmental effects between pure battery EVs (BEVs) and plug-in hybrids (PHEVs) on one hand and conventional internal combustion engine (ICE) vehicles using gasoline and diesel on the other side.

In recent years, the focus in environmental assessments of EVs was on global warming and primary energy demand. But now it is recognized that other impacts gain additional relevance and must be addressed by life cycle based comparisons like water, land use, resource consumption, local particulate matter (PM) and NO<sub>x</sub>-emissions. Therefore, Task 30 focuses also on following topics covering methodologies, data and case studies:

- effects of EVs on water (emissions to water, waste water, “Water Footprint” of EVs),
- effects on EVs on air (local emissions and effects of NO<sub>x</sub>, PM and C<sub>x</sub>H<sub>y</sub>, human health effects and non-energy related emissions from tires and brakes),
- effects on EVs on land use – resources - waste (land use, occupation and degradation, demand of renewable and fossil resources, recycling), and
- overall environmental effects and their assessment (comparing and assessing different impact categories, single score methodologies, stakeholder involvement).

### 1.3 Approach

Within Task 30, methodologies are developed to help countries to implement EVs by identifying possibilities to maximize the environmental benefits. Besides, various case studies are analysed and networking combined with information exchange is supported within the Task’s frames ([Figure 2](#)).

The Task proceeds by organizing a series of expert workshops addressing the following objectives:

- methodologies on assessment of environmental effects,
- analyses of necessary and available data,
- overview of international studies/literature,
- analyses of current knowledge and future challenges,
- overview of key actors and stakeholders and their involvement,
- communication strategies to stakeholders, and
- summarizing further R&D demand.

The results are continuously documented and disseminated via e.g. presentations, workshops, conference contributions and publications.

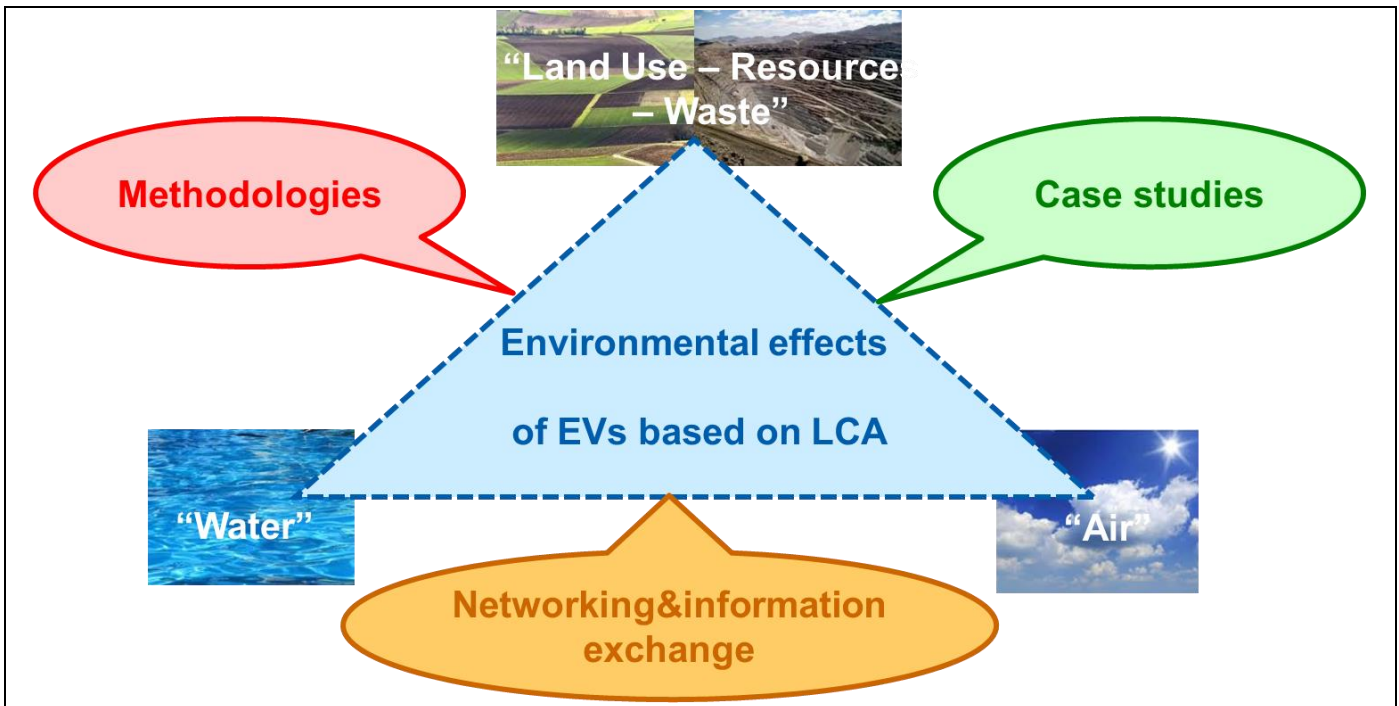

Figure 2: Approach of Task 30

## 1.4 Cooperations and Partners

### 1.4.1 IEA HEV TCP

The Hybrid and Electric Vehicle Technology Collaboration Programme (HEV TCP) enables member parties to discuss their respective needs, share key information, and learn from an ever-growing pool of experience from the development and deployment of hybrid and electric vehicles. (see [www.ieahev.org](http://www.ieahev.org))

The HEV TCP was formed in 1993 to produce and disseminate balanced, objective information about advanced electric, hybrid and fuel cell vehicles. It is an international membership group collaborating under the International Energy Agency (IEA) framework. TCPs are at the core of the IEA International Technology Co-operation Programme coordinated by the IEA Committee on Energy Research and Technology (CERT). HEV TCP is now in its sixth five-year term of operation that runs from March 2020 until March 2025. An annual report is published each year, which details work completed under the HEV TCP and news from member countries.

### 1.4.2 Membership to the HEV TCP

The HEV TCP offers two types of membership: Contracting Parties and Sponsors. Members designate a representative to serve on the Executive Committee that provides overall direction, approves the budget, and formulates policy and strategy. The HEV TCP's primary work is conducted through Tasks.

The 19 active Contracting Parties (member countries) as of May 2021 are

1. Austria,
2. Belgium,
3. Canada,
4. China,
5. Denmark,
6. Finland,
7. France,
8. Germany,
9. Ireland,
10. Italy,
11. The Netherlands,
12. Norway,
13. Republic of Korea,
14. Spain,
15. Sweden,
16. Switzerland,
17. Turkey,
18. United Kingdom and
19. The United States.

### 1.4.3 Governance and Management

The work of HEV TCP is governed by the Executive Committee ("ExCo"), which consists of one member designated by each Contracting Party. Contracting Parties are either governments of IEA countries or parties designated by their respective governments. The HEV TCP ExCo meets twice a year to discuss and plan the working programme.



### 1.4.4 Tasks

The actual work of the HEV TCP is achieved through a variety of different Tasks that are focused on specific topics. Each topic is addressed in a Task, which is managed by an Operating Agent (OA). The work plan of a new Task is prepared by an interim OA, either on the OA's own initiative or on request of the ExCo, and the work plan is then submitted for approval to the HEV TCP ExCo.

The currently ongoing tasks are (Status of webpage January 2022):

- Task 1 Information Exchange serves as a platform for information exchange among member countries.
- Task 23 Light-Electric-Vehicle Parking and Charging Infrastructure: aims to represent the interests of local governments in the standardisation of Light Electric Vehicle system architectures, infrastructure, communications and interchangeable batteries.
- Task 29 Electrified, Connected and Automated Vehicles: analyses the potential technological synergies of electrification, connectivity and automation of road vehicles and derive research, development and standardisation need.
- Task 30 Assessment of Environmental Effects of Electric Vehicles: aims to analyse and assess environmental effects of EVs on water, land use, resources and air based on LCA and in cooperation with participating countries in the HEV TCP.
- Task 32 Small Electric Vehicles: the objective of this task is to promote broader commercialisation, acceptance and further development of SEVs.
- Task 34 Batteries: aims to encourage the sharing and dissemination of current information about battery topics of interest to the vehicle community.
- Task 35 Fuel Cell Vehicles: aims at supporting a broader commercialization, acceptance and a further development of fuel cell electric vehicles (FCVs).
- Task 37 Extreme Fast Charging: aims to focus on the following objectives: investigating station siting – what factors are considered (i.e. space requirements, city centre, community/corridor).
- Task 38 Marine Applications (e-Ships): aims to focus on overviewing and encouraging the development and deployment of e-Ships, by building and sharing key knowledge on projects, performance, segments and demand.
- Task 39 Interoperability of e-Mobility Services: aims to focus on the charging infrastructure and more specifically on the interoperability aspects of e-mobility services like charging of passenger cars in the public and semi-public domain.
- Task 40 CRM4EV – Critical Raw Materials for Electric Vehicles: aims to focus on projected mass deployment of EVs, attention is drawn to potential supply chain issues for several Critical Raw Materials (CRMs) needed for EV manufacturing.

- Task 41 Electric Freight Vehicles: aims to monitor progress and review relevant aspects for a successful introduction of electric freight vehicles (EFV) into the market.
- Task 43 Vehicle/Grid Integration: analysing the challenges identified on the integration of the electric vehicles into our electricity and transport system in order to improve economic and environmental performance.
- Task 45 Electrified Roadways (E-roads): aims to develop a greater global understanding and awareness of electrified roadways (E-Roads), as well as related technologies developed and deployment activities in the participating countries.
- Task 46 LCA of Electric Trucks, Buses, 2-Wheelers and other Vehicles: aims to analyse environmental effects based on LCA of e-buses, e-trucks, e-2-wheelers and other e-vehicles in comparison to conventional vehicles and the use of e-fuel and hydrogen.
- Task 48 Battery Swapping: aims to focus on creating stronger infrastructure for battery swapping technology and swapping of information.

### 1.4.5 Partners in Task 30

The following partners in 7 countries cooperate in Task 30 with their own financing ([Figure 3](#)):

- Spain: IREC – Catalonia Institute for Energy Research,
- Canada: CIRAIK - International Reference Centre for the Life Cycle of Products, Processes and Services,
- Germany: DLR - Deutsches Zentrum für Luft- und Raumfahrt (German Aerospace Center),
- Republic of Korea: Ulsan University,
- Turkey: Sabanci Universitesi
- USA: Argonne and
- Austria: JOANNEUM RESEARCH.



 <p>➤ <b>Participants</b></p> <ol style="list-style-type: none"> <li>1. <b>Austria</b> – JOANNEUM RESEARCH</li> <li>2. <b>Canada</b> – CIRAIG</li> <li>3. <b>Germany</b> – DLR</li> <li>4. <b>Korea</b> – University of Ulsan</li> <li>5. <b>USA</b> – Argonne</li> <li>6. <b>Spain</b> – IREC</li> <li>7. <b>Turkey</b> – Sabanci University</li> </ol> <p>➤ <b>Management</b></p> <ul style="list-style-type: none"> <li>➤ Operating agent: Gerfried Jungmeier</li> <li>➤ Deputy operating agent: Víctor José Ferreira</li> </ul>	
--	---

Figure 3: Countries and institutions in Task 30

### 1.4.6 National Project Advisory Board

A National Project Advisory Board was initiated by the funding agencies (FFG and Climate and Energy Fund) and established in 2018. The National Project Advisory Board had one meeting in each year (2018, 2019, 2020, 2021 and 2022) during the working period of Task 30.

The following activities of the National Project Advisory Board were mainly motivated to stimulate the information exchange in Austria:

- The operating agent informed on the actual activities and results (e.g. highlights) on the international level and the Austrian contributions.
- Strategic accompaniment, professional consultation and support on transferring the task activities and (interim) results.
- Information exchange on the Austrian actives in the TCP HEV – Hybrid and Electric Vehicle, AMF – Alternative Motor Fuels and AFC – Advanced Fuel cells.

The members of the National Project Advisory Board were:

- KLIEN: Gernot Wörther,
- FFG: Maria Bürgermeister-Mähr,
- BMK: Andreas Dorda, Constanze Kiener, Reiner Reinbrech,
- Energy Agency: Walter Mauritsch,
- JOANNEUM RESEARCH: Gerfried Jungmeier, Martin Beermann,
- BEST - Bioenergy and Sustainable Technologies: Dina Bachovsky, Andrea Sonnleitner and
- HyCentA – Hydrogen Center Austria: Alexander Trattner.

The following IEA tasks/annexes of the TCPs were represented by these members:

- HEV:
  - Task 30 „Environmental Effects of Electric Vehicles” (G. Jungmeier)
  - Task 33 „Battery Electric Buses“ (G. Jungmeier)
  - Task 40 “CRM4EV Critical Raw Material for Electric Vehicles” (M. Beermann)
  - Task 41 “Electric Freight Vehicles” (A. Bhashyam)
  - Task 46 “LCA of Electric Trucks, Buses, 2-Wheelers and other Vehicles” (G. Jungmeier)
- AMF
  - Annex 58 „Transport decarbonisation“ (D. Bacovsky)
  - Annex 59 „Lessons Learnt“ (A. Sonnleitner)
- AFC - Annex 34 “Transport Applications“ (A. Trattner)

## 2 Results

After an overview of the results, the detailed results are described.

### 2.1 Overview

The results are structured the following:

- Expert Workshop on Water Issues (see also Annex 1),
- Expert Workshop on Effects on Air (see also Annex 2),
- Expert Workshop on Resources, Waste and Land Use (incl. LCA Autonomous Vehicles) (see also Annex 3),
- Expert Workshop on Impact Assessment (see also Annex 4),
- Rebound Effects of Electric Vehicles and Possible Implication on Environmental Effects in LCA,
- Evaluation of the Environmental Benefits of the Global EV-Fleet in 38 Countries,
- Issues on Dynamic LCA of Vehicle Fleets and
- Dissemination activities.

### 2.2 Expert Workshop on Water Issues

#### 2.2.1 Introduction

In January, 2017 Task 30 held an expert workshop on the environmental effects of electric vehicles (EVs) on water, energy consumption and air emissions based on life cycle assessment in Graz/Austria.

The aim of the workshop “Environmental Effects of Electric Vehicles (EV) – Water Issues and Benefits of EV-Fleets on Energy Consumption and Air Emissions” was to present and discuss the current status and

the future perspectives of the environmental performance of electric vehicles in comparison to conventional vehicles with an internal combustion engine (ICE) in a life cycle perspective. The main focus is on Battery Electric Vehicles (BEV) and Plug in Hybrid Electric Vehicles (PHEV).

The two topics for the workshop were:

1. Water issues and
2. Benefits of EV-fleets on energy consumption and air emissions.

The format of the workshop was based on presentations, discussion and group work with focus on

- Data requirements
- Case studies
- Identification of main issues in LCA of EVs and ICE
- Identification of “hot spots” on water issues of EVs, PHEVs and ICEs
- Communication of LCA results to stakeholders, e.g. Fact Sheet
- Findings and Recommendations

### 2.2.2 Results

#### 2.2.2.1 Overview

In an interactive group work, the following key issues were discussed, summarized and documented:

- Main drivers
- Water inventory
- Most relevant water issues for LCA of EV and ICE
- “Water footprint”
- Water issues in electricity production
- Water issues in value chain of EVs and ICE
- Research questions on water issues & EVs
- Possible activities of IEA HEV Task 30

#### 2.2.2.2 Main Drivers

The key drivers to work on water issues are

- water is a key factor for sustainable development goals,
- agriculture (incl. biofuels),
- electricity production in thermal power plants and hydro power plants and
- waste water from industry and population as a pollution of rivers, lakes and seas.

### 2.2.2.3 Water Inventory

The starting point of an LCA on water issues is a water balance for the most relevant processes of EVs and ICE. Ideally, the water balance of each process is closed, as all inputs equal the outputs incl. the transformation of hydrogen into water, e.g. due to a chemical reaction. The water inventory must include the water inputs and water outputs by providing the data on process level with its geographical location:

- input water: source, volumes, temperature, quality,
- discharge water: sink, volumes, temperature, quality and
- emissions to water: specifically amounts of N, P, heavy metals and organic loading.

For a proper impact assessment the inventory data including uncertainties are needed by:

- region,
- timeframe (current, future),
- state of technology and
- data source: original, secondary and tertiary data.

### 2.2.2.4 Most Relevant Water Issues for LCA of EV and ICE

The most relevant water issues in LCA of EV and ICE are:

- Inventory:
  - water evaporated (blue water use),
  - water flow alteration (for hydro power),
  - water emissions (impurities that affect water quality),
  - thermal emissions,
- Impact assessment:
  - water consumption factor (WCF),
  - water scarcity,
  - water Stress Index or kind of such an index number,
  - water eutrophication and
  - water toxicity.

### 2.2.2.5 Water Footprint

Water Scarcity Footprint = Water Consumption \* Water Scarcity Index

in analogy to

Carbon Footprint = Greenhouse Gas Emissions \* Global Warming Potential

The commonly often used wording of “*water footprint*” gives only information on the amount of water and is, as such, on an LCA inventory basis, e.g. water consumption. Carbon footprint, on the other hand, is

an LCA impact category. An LCA on water issues requires the water footprint but also water scarcity, eutrophication and toxicity.

Water issues in LCAs should be considered because water is relevant part of the sustainable development goals and will in future play an increasingly important role. As a result, water LCA and carbon footprint should be combined to create DALYs (disability/disease-adjusted life years lost) for impact category “Human health” and PDFs for “Ecosystem quality”.

#### 2.2.2.6 Water Issues in Electricity Production

The water consumption is mainly relevant for thermal power plants and hydro power plants. For thermal power plants, the water consumption mainly depends on the type of cooling technology, whereas for hydro power the allocation of the water consumption to the different purposes of a hydro dam (e.g. electricity, flood control, navigation, recreation, and irrigation) is most influencing.

The total environmental damage (e.g. "Eco-Indicator 99" - Ei 99+) comparing different electricity generation systems might lead to two findings:

- 1) water is most relevant for hydro power but
- 2) the total environmental damage of hydro power is significantly lower compared to natural gas and coal.

#### 2.2.2.7 Water Issues in Value Chain of EVs and ICE

The following processes are most important in the value chain of EVs and ICE ([Figure 4](#)):

- ICE (incl. blending of biofuels):
  - fossil fuel extraction and refining (e.g. Tar sands, oil shale or traditional oil),
  - cultivation of feedstock for biodiesel and bioethanol (e.g. for B5, E10),
  - vehicle production,
- EV (only BEV and PHEV):
  - electricity generation (e.g. thermal open cycle, closed cycle, or hydro power) and
  - battery production (specifically because of pollutants for mineral extraction and refining).

The comparison of water issues of EV and ICE shows that the life cycle based water consumption of EV might be higher than from ICE. Main reason is the electricity production from hydropower and thermal power plants. For ICE the most relevant influence on water consumption depends on the amount of biofuel blended (biodiesel in diesel or bioethanol in gasoline), as the agricultural production of the feedstock for biofuels is most relevant for water issues, e.g. most of the water consumption for E10 gasoline ICE vehicle in the USA derives from corn cultivation for bioethanol.

The comparison of water withdrawal and consumption for fuel supply show that

- for the ICE about 50% of the water withdrawal and about 80% of the water consumption is needed for the gasoline supply and

- for the EV about 90% of the water withdrawal and about 80% of the water consumption is needed for the electricity supply.

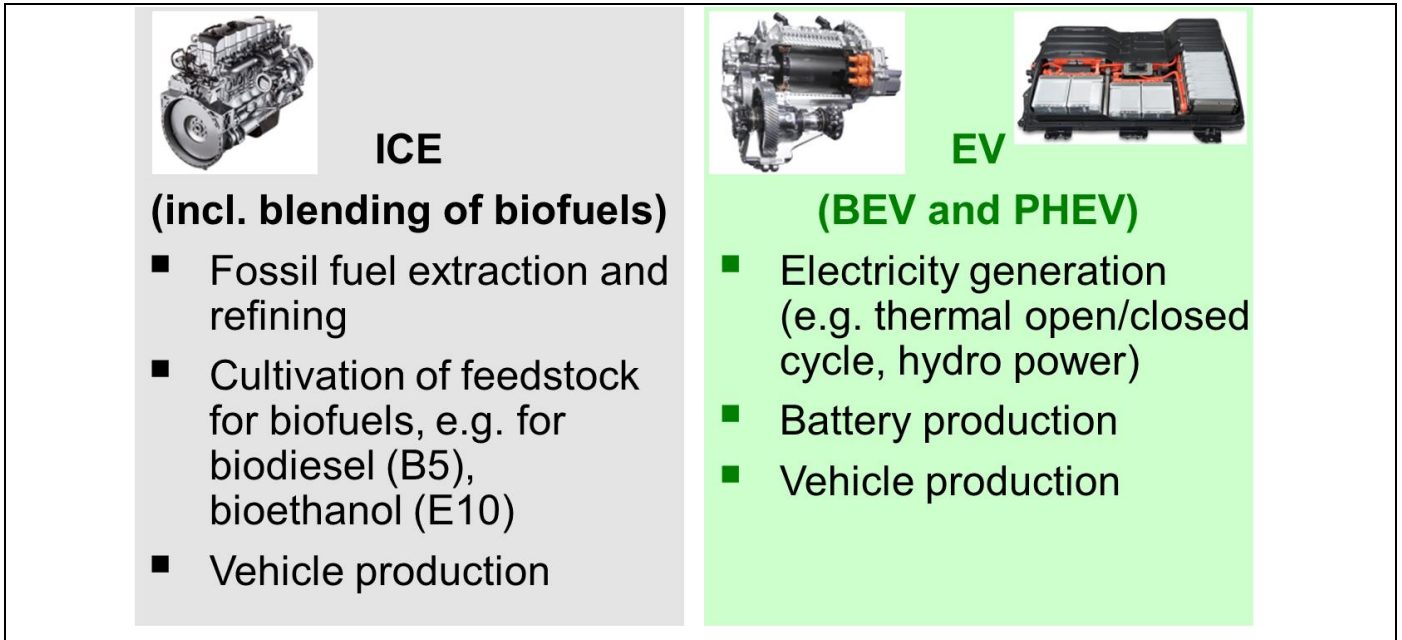

Figure 4: Main water issues in LCA of ICE and EV

### 2.2.2.8 Research Questions on Water Issues & EVs

- How to reduce the water impacts of EVs?
- Reduction of uncertainties in assessment. This requires:
  - basic data for the inventory at the regional level and
  - improved data of water inputs and emissions in the construction and dismantling of the EVs.
- How does a broader use of EVs impact water stress in a given region?
- Preparedness for the possibility that water becomes a “show stopper”. This requires a proper communication strategy of results and uncertainty of results.
- Including water vapour as a climate forcing.

### 2.2.2.9 Possible Activities of IEA HEV Task 30

The Task 30 might work on the following activities:

- A report giving a summary of the current state of knowledge on water issues in the LCA of EVs covering
  - methodological aspects,
  - data issues,

- case studies comparing EVs and ICEs and
- further R&D demand.
- Collection and compilation of water consumption (WCF) of global electricity production to analyse and assess water consumption of current global EV fleet. This might than be included in the FACT SHEETS for the IEA HEV countries and worldwide.
- Screen methodologies, data and case studies to expand analyses and assessment to include
  - stress index (or other kind of index) by region/scenario and
  - impact assessment (e.g. water quality, thermal pollution, etc.).

## 2.3 Expert Workshop on Effects on Air

### 2.3.1 Introduction

In September 2018, Task 30 held an expert workshop on emissions to air in the LCA of electric vehicles in Stuttgart/Germany.

The aim of the expert workshop of Task 30 was to analyse and assess environmental effects of electric vehicles (EVs) on emissions to air based on life cycle assessment in a cooperation of the participating countries in the International Energy Agency (IEA).

The aim of the workshop was to present and discuss the current status and the future perspectives of emissions to air in the LCA of Electric Vehicles in comparison to conventional vehicles with an internal combustion engine (ICE).

In a group of relevant stakeholders from government, industry, research and NGOs the relevant issues of effects on air emissions were identified and discussed referring to the ongoing large-scale market introduction of EVs.

### 2.3.2 Results

The summarized results of the workshop are the following:

- The main air emissions analysed in the inventory (LCI) and assessed (Impact Assessment) are CO<sub>2</sub>, NO<sub>x</sub>, SO<sub>2</sub>, CO, PM, CH<sub>4</sub> and N<sub>2</sub>O.
- The main sources of these air emissions in LCA of EVs and ICEs are
  - ICE-vehicle,
  - PHEV-vehicle,
  - thermal power plants providing the electricity for the EVs and
  - oil refineries to convert raw oil to gasoline and diesel.
- These main sources of air emissions must be documented in the foreground data in the LCA (beside the energy consumption of the vehicles) explicitly to allow better communication and comparison of the LCA results.
- The main impacts directly related to these air emissions are



- global warming potential in CO<sub>2</sub>-equivalent (CO<sub>2</sub>, CH<sub>4</sub>, N<sub>2</sub>O),
- acidification in SO<sub>2</sub>-equivalent (NO<sub>x</sub>, SO<sub>2</sub>) and
- ozone formation in C<sub>2</sub>H<sub>4</sub>-equivalent (CH<sub>4</sub>, NO<sub>x</sub>, CO, NMVOC).
- The Canadian Case Study also assessed Human health (DALY) and Ecosystem Quality (PDF m<sup>2</sup> year).
- The air emission of ICE and PHEV vehicles should be derived from real world driving conditions including user behavior and climate conditions reflecting the cooling and heating demand in different regions/countries.
- Most LCA studies presented comparing EVs and ICE vehicles mainly analyse and assess GHG emissions and primary energy demand, only few studies also assess other impact categories, e.g. air emissions.
- The emissions associated with the production and end of life of the automotive batteries are a very relevant issues, whereas currently the “generally accepted” GHG emissions are 175 (150 - 200) kg CO<sub>2</sub>-eq/kWh (ivl 2017, ICCT 2018) and referring to about 35 g CO<sub>2</sub>-eq/km (ICCT 2018) ([Figure 5](#)).
- Other air emissions from battery production where not presented.
- As the development of automotive batteries is very quick and innovate as well as the mass production of automotive battery production is starting these days, no new average data on battery production based on material demand and energy demand for cell and system assembling were presented.
- The end of life (EoL) of automotive batteries might become relevant for the impacts of battery production. Two different EoL strategies are discussed, the materials recycling and the 2<sup>nd</sup> use in a stationary application. Generally, it is not expected that the direct use of the old automotive batteries (<80% SOC) for stationary application (e.g. storage for PV plant) will gain commercial interest. A commercial business case could be to disassemble the cells and use the “best” cells to make a new stationary battery to give adequate warrantee.
- For the LCA of batteries the EoL might have significant influence in the case of 2<sup>nd</sup> use, as a significant part of the impacts of battery production might be allocated to the automotive and the stationary use, e.g. allocated according to the total electricity throughput in these two applications. The case of material recycling might not affect the total impact of automotive batteries significantly, as the increasing amount of battery production volume requires big amounts of primary materials while the recycling material is still limited to the small number of used automotive batteries available for recycling ([Figure 5](#)).
- The general results of the LCAs comparing ICE and EVs show the following
  - If the BEVs use a high share of renewable electricity, the impacts on air emissions are significantly lower than from ICE.
  - Besides using renewable electricity, the impacts of PHEV strongly depend on the share of electric driven kilometres. In electric mode the PHEV has similar impacts than the BEV. In combustion mode, the impacts of a PHEV are more or less equal to an ICE or an HEV.



- If the electricity used for the EVs has a high share of fossil based electricity the impacts of the EVs are similar to the impacts of an ICE.
- Modelling can also be done using dynamic LCA data on electricity production in order to determine CO<sub>2</sub>-eq, e.g. per half hour interval due to electricity production. This can help to set policies considering not only the supply and demand of electricity, but also for charging the vehicles when renewables are supplying electricity to the grid.
- Currently, the LCA based comparison of EVs and ICE is done for single vehicles, whereas now first applications of LCA to whole fleets of vehicles become relevant, e.g. when modelling future scenarios to fulfil PARIS targets.
- In applying LCA to vehicle fleets, the questions of really substituting ICEs by EVs become more and more relevant. It is observed, that the global, national and regional vehicle stocks of ICE are still growing while also the stock of EVs is growing, even much faster than those of ICEs. Additionally, it is observed that EVs become also the 2<sup>nd</sup> and 3<sup>rd</sup> vehicle in households. For LCA used in scenario analyses or for whole fleets of vehicles, these developments mean that not every new EV may replace an ICE in reality. These effects are called “(direct) rebound effects”.
- For applying LCA to EV fleets compared to ICE fleets, a methodological approach must be developed to integrate possible rebound effects in the LCA methodology, e.g. that 1 driven km by an ICE is not 100% substituted by an EV.
- The methodological combination of LCA with scenario analyses will become interesting in future, in which a burden shifting from transport sector in the electricity or industry sector becomes relevant and must be shown explicitly. There is also the possibility of using consequential LCA analysis to model this effect.

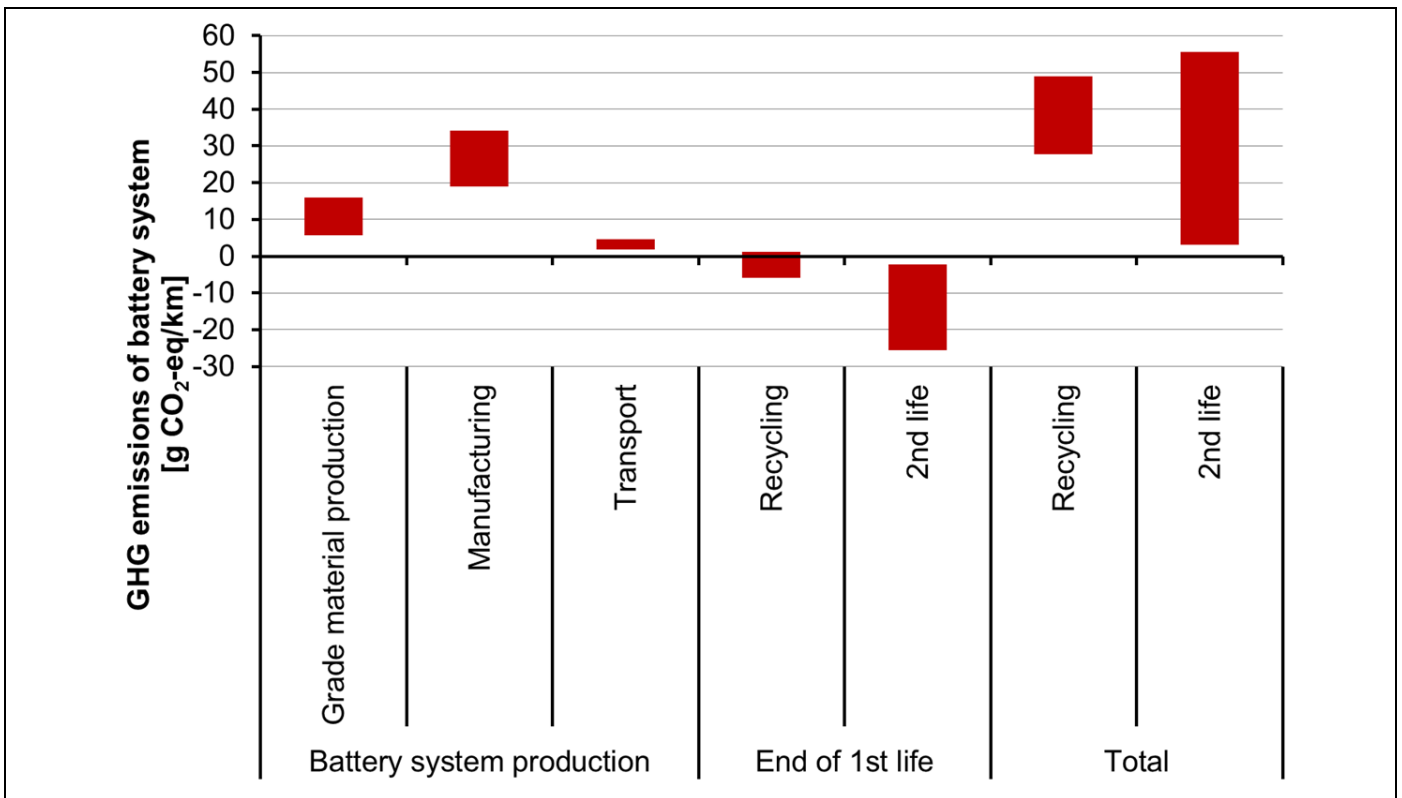

Figure 5: Estimated ranges of GHG emissions from battery system per km

### 2.3.3 Identified Key issues

In the workshop, the key issues on “Emissions to Air in the LCA of Electric Vehicles” were identified and discussed. The 6 key issues were grouped the following

- Manufacturing of vehicle and battery
- Vehicle operation
- Electricity for EVs
- End of life (EoL) of batteries
- Battery characteristics
- Data availability and quality

The details collected and discussed on these 6 key issues were

- Manufacturing of vehicle and battery
  - Air emissions of (future) battery production
  - New inventory data on battery production
  - Energy demand of battery production
  - Vehicle manufacturing
  - Impacts of mining the materials

- Vehicle operation
  - Use and document real world energy consumption and emission data for ICE, BEV and PHEV
  - Non greenhouse gases
    - Function of exhaust gas treatment
    - “non linearity”
    - Dependent on conditions
  - Influence of user
    - Driving profiles
    - Charging behaviors
    - Thermal comfort
    - Rebound effects
  - Influence of climate (cold weather can decrease battery efficiency, hot weather can cause faster battery degradation)
- Electricity for EVs
  - Reliable air emission data of electricity generation today and in future
  - Air emissions of renewable electricity generation mainly based on material used
  - Electricity generation mix and future developments
  - Influence of flexile charging (mix versus marginal)
  - Regional dynamic grid mix
  - Handling of import and export of electricity in region/country
  - Include storage for renewable electricity (esp. PV and wind)
- End of life (EoL) of batteries
  - Recycling vs. 2<sup>nd</sup> life
  - Assessing 2<sup>nd</sup> use and recycling
  - Estimation on influences of EoL for vehicles and batteries on LCA comparison
- Battery characteristics
  - Energy density of battery
  - Battery life time
- Data availability and quality
  - ICE and PHEV: NO<sub>x</sub>, PM, C<sub>x</sub>H<sub>y</sub>
  - Thermal power plants: NO<sub>x</sub>, PM, C<sub>x</sub>H<sub>y</sub>, SO<sub>2</sub>; share of heat use in CHP plants
  - Pre-chain air emissions, e.g. steel, lithium, aluminum, copper
  - Indicators for data quality
  - Data availability: how to close data gaps

### 2.3.4 Future Developments on LCA of EVs

In the workshop, the following future developments in the LCA of EVs were identified and discussed:

- Air emissions of ICE, PHEV, power plants and refineries must be foreground data
- Are there any other relevant air emissions beside NO<sub>x</sub>, SO<sub>x</sub>, CO, PM?
- Find and define reasonable ranges for air emissions in LCI and LCA
- Consider regional and seasonal differences of vehicle operation and electricity
- Where is or might be a problem of air emissions with EVs? Are there possible solutions?
- Parameters to decide on electricity generation for EVs
- Criteria to decide on marginal vs. current/future electricity grid mix
- System boundaries with or without 2<sup>nd</sup> battery life as energy storage
- Consideration of building new infrastructure (macro level vs. functional unit level) (charging infrastructure)
- Criteria to include or exclude impacts from road infrastructure
- Impact assessment of GHG emissions with CO<sub>2</sub>-eq or contribution to the future increase/decrease of global temperature
- Systematic description of results showing the shares of emissions of sectors and countries: burden shifting between countries and between sectors
- Possible rebound effects and influences on LCA results which might be reflected in the new functional unit
- Time effects in LCA: changing of electricity mix during lifetime of EV
- Develop LCA methodology to be applied for vehicle fleets and identify differences to “single vehicles”

## 2.4 Expert Workshop on Resources, Waste and Land Use (incl. LCA Autonomous Vehicles)

### 2.4.1 Introduction

In June 2019, Task 30 held an expert workshop on the effects of EVs on land use, resources and waste in Washington D.C., USA. The aim of this expert workshop was to analyse and assess environmental effects of EVs on land use, resources and waste based on LCA in a cooperation of the participating countries in the IEA. The current status and the future perspectives of LCA of EVs on these issues in comparison to conventional vehicles with an ICE were presented and discussed. The focus was on BEVs and PHEVs.

In a group of relevant stakeholders from government, industry, research and NGOs, the relevant issues of effects on land use, resources and waste were identified and discussed referring to the ongoing large-scale market introduction of EVs.

## 2.4.2 Results on Resources and Waste

Concerning the effects of resources and waste following topics were discussed:

- a) LCA of battery production,
- b) LCA of battery recycling,
- c) LCA of electric motor recycling (mainly magnets) and
- d) LCA of power electronics recycling.

### 2.4.2.1 LCA of Battery Production

The following key battery materials were updated in GREET (LCA model):

- cobalt: shares of Co coproduced with Ni/Cu; shares of sulphide/laterite; ore grade,
- nickel: shares of sulphide/laterite; ore grades; SO<sub>x</sub> emissions control,
- lithium: shares of lithium produced form brine/minerals and
- graphite: shares of natural/synthetic graphite.

The most relevant categories on energy demand and emissions of an NMC111 LIB under baseline conditions are:

- NMC111 Cathode: Cobalt (sulfate production); Nickel (refining); other cathode steps (NMC11 precursor & powder production),
- aluminum: alumina reduction & SF<sub>4</sub>/S<sub>2</sub>F<sub>6</sub> abatement,
- battery management system (BMS): electricity source and
- cell assembly: heat and electricity source.

As an example in [Figure 6](#) the Cradle-to-Gate environmental impacts of 1 kWh NMC111 battery are shown, where cathode, production energy and aluminum are notable contributors.

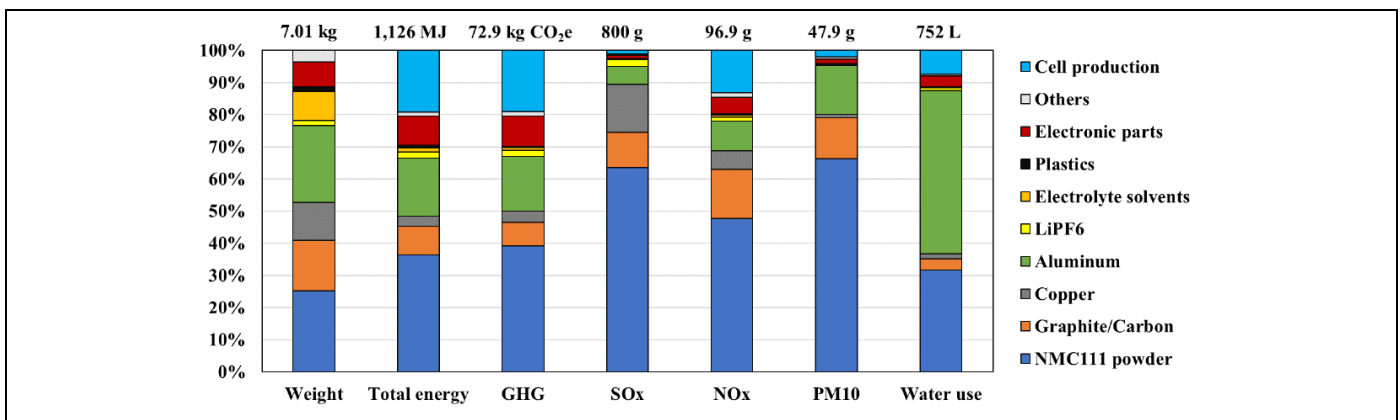

Figure 6: Cradle-to-Gate environmental impacts of 1 kWh NMC111 battery<sup>1</sup>

<sup>1</sup> L Gaines: *LCA and Direct Recycling for Lithium Ion Batteries*, Presentation at Task 30 workshop, June 2019

#### 2.4.2.2 LCA of Battery Recycling

Actually, there are three main processes for recycling of batteries:

1. pyro process for recycling of batteries,
2. hydro process for recycling of batteries and
3. direct recycling of batteries (under development).

Based on current experiences in Germany initial conclusions on battery recycling are drawn:

- A careful dismantling offers significant environmental benefits.
- Major credits are possible from housing materials and other components (e.g. from recycling of steel, aluminum, copper, precious metals).
- Recycling of battery cells offers credits for Co, Ni, Cu; furthermore lithium recycling would be possible, but a further process development is necessary.
- Huge importance for attenuating pressure on primary demand for key materials.

#### 2.4.2.3 LCA of Electric Motor Recycling (Magnets)

An LCA was performed within the German project “MORE – Recycling of components and strategic metals from electric motors”. The following three different processing routes were analysed with the major interest to recover neodymium (Nd) and dysprosium (Dy):

1. direct reuse (cleaning): production of 1 kg magnet via reuse,
2. remelt (closed loop magnet remelting): production of 1 kg secondary magnet (70% primary and 30% secondary materials) and
3. feedstock recycling (recovery of “rare earth” oxides from EoL-magnets): production of 1 kg “rare earth” oxide (mixed or separated).

The initial conclusions regarding LCA of electric motor recycling (magnets) are:

- Major GHG emission credits for recovery of RE oxides, also remelting with secondary share of 30% offers benefits.
- GHG emissions of recovery effort generally well outweighed by credits for Nd and Dy oxides, magnitude strongly depends on allocation method (economic or mass based).
- In addition, other categories show strong credits for recovery of RE oxides.
- Data availability for assessment of primary production of RE, especially Dy, is very limited and uncertain.

#### 2.4.2.4 LCA of Power Electronics Recycling

An LCA was performed within the German project “ElmoRel 2020 – Electric vehicle recycling 2020 – key component power electronics”. The following three different processing routes were analysed

1. conventional car shredder (reference route),

2. dismantling & Waste of Electrical and Electronic Equipment (WEEE) recycling of power electronics and
3. dismantling & WEEE recycling of power electronics incl. chemical dissection of PCB.

The initial conclusions in relation to LCA of power electronics systems are:

- In comparison to the conventional car shredder route, extraction of power electronics unit enables high recovery rates for gold, silver and palladium; recovery rates of tin and copper can also be increased.
- LCA shows good results for both routes, with dedicated WEEE recycling providing additional benefits from some higher recovery rates and corresponding credits.
- Main benefit of dedicated WEEE recycling from a resource conservation perspective.
- The effort for the additional recovery of tantalum (Ta) from PCB seems to be too high as to be environmentally attractive.
- The WEEE recycling route is economically viable, but offers a lower profit margin than the car shredder route.

#### 2.4.2.5 Results on Land Use, Resources and Waste

The possible relevant environmental effects and discussion points of land use are the following:

- more than half of the earth's terrestrial land is actively being used by humans,
- resulting loss of biodiversity and soil functions expressed by ecosystem services is of scientific, political, societal and economic concern,
- many methods to address land use impacts in LCA are developed and
- mandatory requirement: globally available, country specific as well as region specific characterization factors (CF).

Land use is correlated to occupation of land and transformation of land. In relation to LCA, the inventory data are relevant for land occupation [ $m^2 \cdot a$ ] and land transformation [ $m^2$ ]. However, especially for mining processes these input data are often not known exactly and are therefore estimated. So far, there is no consistent comparison of possible land use effects of EVs and ICEs available, but for EVs mainly the mining activities for battery materials resources and the generation of renewable electricity might be relevant for land use, whereas for conventional ICEs the extraction of oil might be relevant for land use aspects.

Finally, the main issues of resources, waste, and land use that should be addressed in an LCA of EVs were identified in the workshop discussions. These are:

- resources:
  - minerals,
  - fossil fuels,
  - resource criticality,
  - resource depletion not as a primary environmental concern,
  - virgin,

- recycled,
- no consensus on impact assessment methodology in LCA,
- waste:
  - reuse,
  - recycling,
- land use:
  - land transformation [m<sup>2</sup>],
  - land occupation [m<sup>2</sup>\*a],
  - ecosystem services.

In Figure 7 a mind map on “Land Use – Resources – Waste in LCA of EVs” with further details on the key issues is shown.

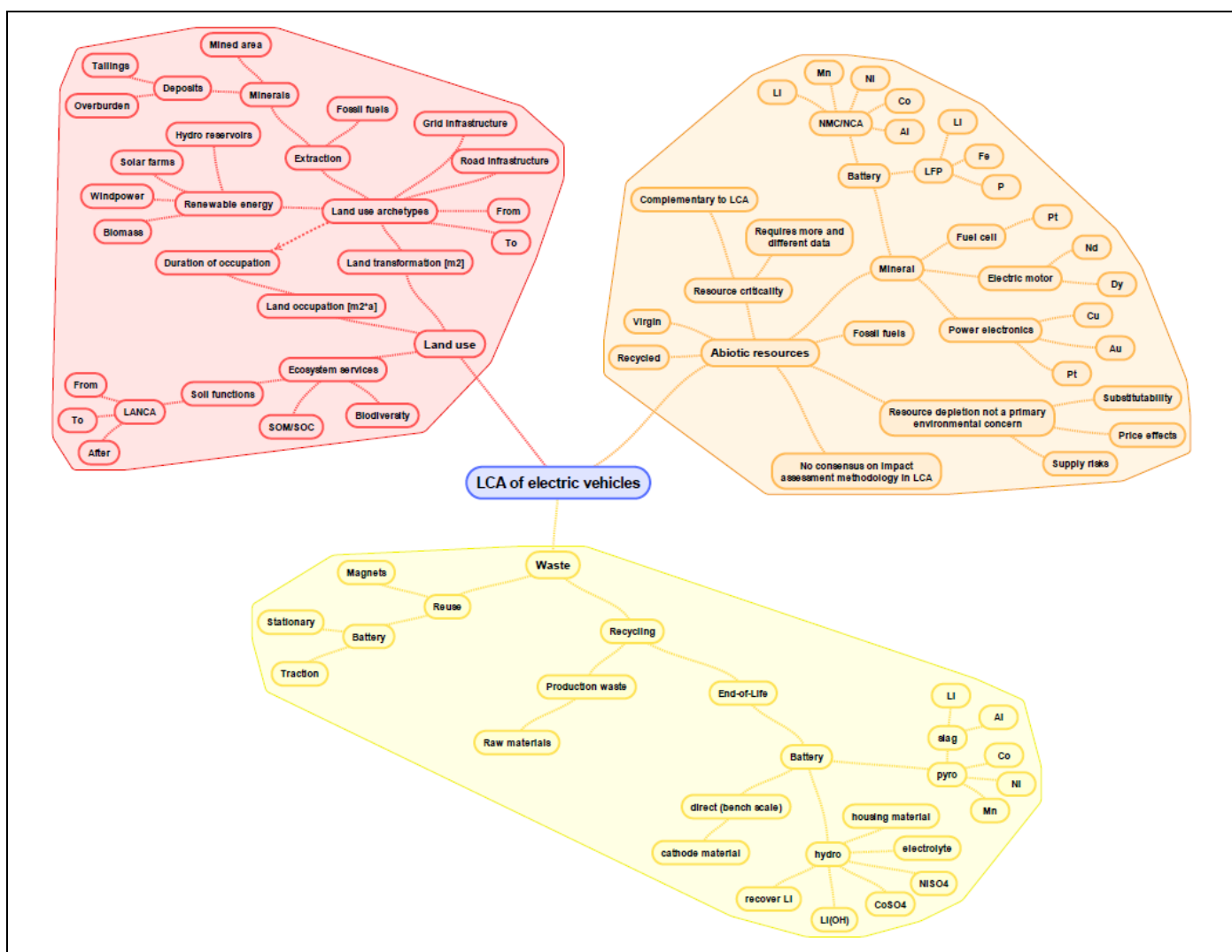

Figure 7: Mind map on “Land Use – Resources – Waste in LCA of EVs”



#### 2.4.2.6 Results on Autonomous Vehicles

A special topic at the above mentioned workshop was on LCA of autonomous vehicles. The aim of this special topic was to present and discuss the evaluation of autonomous vehicles on LCA. Key issues on the LCA of autonomous vehicles were discussed and summarized within an interactive group work focusing on the rapid development of autonomous vehicles.

The vehicle automation is defined at multiple levels, e.g. the Society of Automotive Engineers (SAE) gives 5 levels, with level 0 for no automation:

- Level 1 – 2 require significant human interaction/monitoring of the environment all the times, and the human driver will serve as the fall back plan; this only applies to some driving modes, e.g. cruise control, lane keeping, parking.
- Level 3 – 5 have increasing degrees of “full automation” where the vehicle system is responsible for sensing, actuation and environment monitoring,
  - Level 3: certain driving conditions automated, but driver must be able to intervene,
  - Level 4: certain driving conditions automated, no driver intervention,
  - Level 5: all conditions automated, no intervention.

The promises of vehicle automation are:

- convenience for drivers and passengers,
- reduced congestion,
- increased safety,
- increased productivity,
- faster travel,
- vehicle platooning (improved efficiency),
- lower “taxi” costs (taxi here is inclusive of mobility as service companies),
- drive smoothing (less abrupt start and stops) and
- right vehicle for the trip (mode matching).

The challenges of vehicle automation are:

- rebound effect for distance lived from work,
- increased number of trips, especially taxi trips,
- empty miles (dead-heading),
- automated hunting for parking,
- safety concerns and
- equity and less jobs.

The key parameters possibly affected by autonomous vehicles in an LCA are:

- fuel consumption affecting the operating of vehicles,
- the vehicle size and composition affecting the vehicle manufacturing and
- lifetime of the distance travelled affecting per kilometer/miles from manufacturing the vehicle.

Due to the additional necessary equipment of an autonomous vehicle, the vehicle mass and the additional load are increasing. Current estimations for the additional load are between 200 W and 2 kW. The additional mass can also be compensated by lightweight structures, for which a typical rule of thumb for light weighting is about 7% energy decrease by 10% mass reduction. The smoother driving might reduce energy consumption by up to 15%.

The five main areas of LCA of autonomous vehicles were identified as:

- vehicle level (e.g. energy consumption, vehicle mass changes, level of automation, vehicle lifetime mileage),
- operating conditions (e.g. climate, fleet composition, driving cycles),
- behavior (e.g. user acceptance, user misuse),
- infrastructure (e.g. V2I/V2V – vehicle to infrastructure/vehicle to vehicle, energy consumption, traffic lights, parking space) and
- system level (e.g. rebound effect, mode shift, ride sharing, ride smoothing).

## 2.5 Expert Workshop on Impact Assessment

### 2.5.1 Introduction

The workshop “Overall Environmental Assessment of EVs – From Inventory Analysis to Impact assessment” took place on October 13 and 14, 2021 virtually hosted and organized by IREC (Catalonia Institute for Energy Research) in Barcelona/Spain.

The aim of the expert workshop was to present, discuss and conclude on state of the art and experiences on the overall assessment of environmental effects in LCA of electric vehicles – from “Inventory Analysis to Impact Assessment of EVs”.

### 2.5.2 Impact Assessment

The focus of the expert workshop of Task 30 was to analyse and assess different Impact Assessment methodologies of BEVs and conventional vehicles with an ICE. Based on the inventory analysis of elementary and physical flows in the LCA different impact categories beyond global warming and primary energy consumption are relevant. The way from Inventory Analysis to Impact Assessment is via mid- and end-point indicators. In the workshop the status, the future perspectives and limitations of the Impact Assessment and its impact categories relevant for LCA of vehicles were presented by LCA experts and discussed within the participants.

In [Figure 8](#), the procedure from Inventory Analysis to the Impact Assessment in LCA is shown, where in step 1 the mid-point indicators and in step 2 the possible end-point indicators are assessed. In step 1 and 2 different impact assessment methodologies are applied.

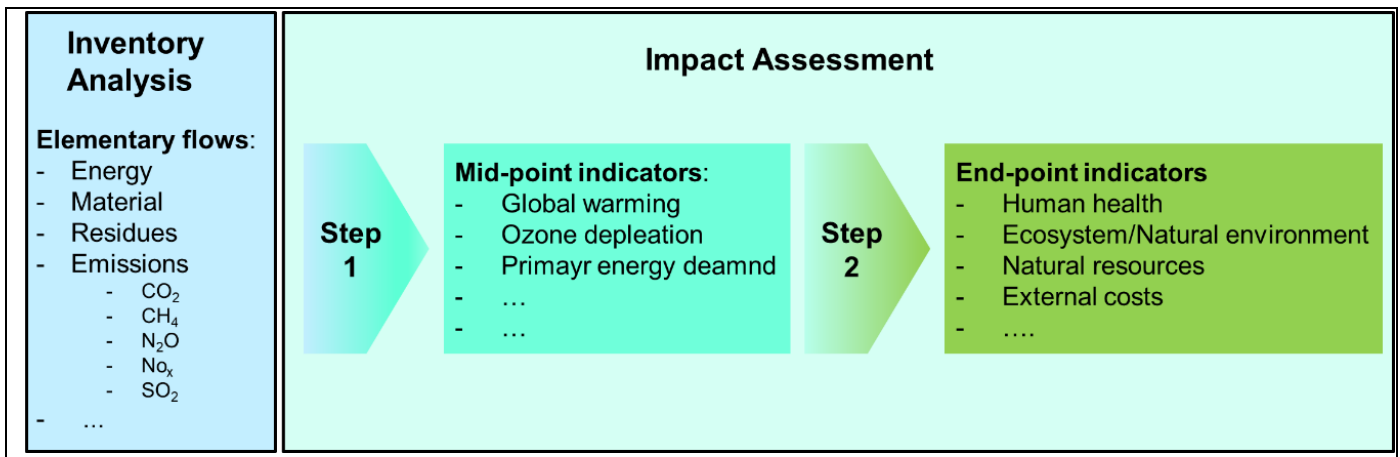

Figure 8: From Inventory Analysis to the Impact Assessment in LCA

Within the workshop, different mid- and end-point indicators with their assessment methodology were presented and discussed.

Regarding the geographical scope of the different impacts, the mid-point indicators are grouped for global, regional and local impacts. The mid-point indicators on these geographical scopes collected in the workshop were:

- global:
  - climate change,
  - ozone depletion,
  - primary energy use (consumption) (fossil and renewable),
  - resource use, minerals and metals,
  - water footprint (based on inventory level method),
  - land use (focus on inventory data),
- regional
  - acidification,
  - photochemical ozone formation,
  - smog formation,
  - eutrophication, terrestrial, freshwater and marine,
  - ionising radiation,
- local:
  - human toxicity, cancer and non-cancer,
  - particulate matter,
  - land use,
  - water scarcity,
  - biodiversity and
  - ecotoxicity, fresh water aquatic, marine aquatic and terrestrial.

Water and land use were allocated to the global and also to the local level. On global level, mainly results from inventory analysis are relevant, whereas on local level a very distinctive methodology might be applied for local impact assessment based on very localized data.

The end-point indicators, which are always assessed on global scale, collected in the workshop are:

- protection areas:
  - human health,
  - ecosystem health,
  - resource availability and
- external costs.

In the following sections, mid- and end-point indicators are described further.

### 2.5.3 Mid-point Indicators

The brief description of global mid-point indicators are:

- Climate change:
  - Radiative forcing as global warming potential - GWP 100 (kg CO<sub>2</sub>-eq)
  - Increase in the average global temperature resulting from greenhouse gas emissions
- Ozone depletion:
  - Ozone depletion potential – ODP (kg CFC-11-eq)
  - Depletion of the stratospheric ozone layer protecting from hazardous ultraviolet radiation
- Primary energy use (consumption/demand) (fossil and renewable):
  - Use of fossil, renewable and nuclear primary energy resources (MJ)
  - Depletion/use of energy resources and deprivation for future generations
- Resource use minerals and metals:
  - Abiotic resource depletion – ADP ultimate reserves (kg Sb-eq)
  - Depletion of mineral and metal resources and deprivation for future generations
- Water footprint:
  - Amount of water consumed (m<sup>3</sup>)
  - Amount and type of water used
- Land use:
  - Occupied land (m<sup>2</sup>)
  - Amount and type of land occupied over a certain time.
  - Amount and type of land transformed

The brief description of regional mid-point indicators are:

- Acidification:
  - Accumulated Exceedance - AE (mol H<sup>+</sup> eq or kg SO<sub>2</sub>-eq)
  - Acidification from air, water and soil emissions (primarily sulphur components) mainly due to combustion
- Photochemical ozone formation:

- Tropospheric ozone concentration increase (kg NMVOC or kg C<sub>2</sub>H<sub>4</sub>-eq)
- Potential of harmful tropospheric ozone formation (“summer smog”) from air emissions on human health?
- Smog formation:
  - Formation of intensive air pollution with decreasing visibility deriving from combustion processes
  - Potential of smog formation (“winter smog”) from air emissions
- Eutrophication, terrestrial, freshwater and marine:
  - Accumulated exceedance – AE (mol N eq)
  - Fraction of nutrients reaching freshwater/marine end compartments (kg N eq)
  - Eutrophication and potential terrestrial impact caused by nitrogen and phosphorus emissions mainly due to fertilizer, combustion, sewage systems
- Ionising radiation, human health
  - Human exposure efficiency relative to U – 235 (kBq U-235 eq)
  - Impact of exposure to ionising radiation on human health

The brief description of local mid-point indicators are:

- Human toxicity, cancer and non-cancer
  - Comparative toxic unit for humans on (non-)cancer (CTUh)
  - Potential impacts on human health via ingestion and inhalation routes. Contact and direct exposure not considered
- Particulate matter
  - Impact on human health (disease incident)
  - Impact on human health caused by particulate matter emissions and its precursors (e.g. sulphur and nitrogen oxides)
- Land use
  - Soil quality index, representing the aggregated impact of land use on: biotic production, erosion resistance, mechanical filtration, groundwater replenishment
  - Transformation and use of land for agriculture, roads, housing, mining or other purposes. The impact can include loss of species, organic matter, soil filtration capacity, permeability
- Water scarcity
  - Weighted user deprivation potential
  - Depletion of available water depending on local water scarcity and water needs for human activities and ecosystem integrity
- Biodiversity
  - Impacts on biodiversity
  - Various methods under development that can be operable and in line with current life cycle inventory phase

Additional also ecotoxicity is a regional impact, which could be an aspect of water and land use as well as biodiversity

## 2.5.4 End-point Indicators

The discussed possible end-point indicators are:

- protection areas and
- external costs.

The protection areas are split in:

- human health, which is measured in DALYs - Disability-Adjusted Life Years or Disease-Adjusted Life Years caused by the various impacts,
- ecosystem health which is measured in PDFm<sup>2</sup>yr - Potentially Disappeared Fraction of species per square meter per year caused by the various impacts and
- resource availability, which is measured in MJ, covering mainly primary energy resources.

The external costs are measured in € (or \$). The external costs assess the damage costs caused by the various impacts, e.g. on human health, ecosystem and infrastructure. Main damage costs caused by climate change impacts, regional air pollution and land use.

## 2.5.5 Assessment Methodologies for Local and Regional Impacts

The following most relevant assessment methodologies for regional and local impacts were identified.

### 2.5.5.1 Human Toxicity Potential

The Human Toxicity Potential (HTP) is a measure of the impacts on human health. The characterisation factors describe the fate, exposure and effects of toxic substances over an infinite time horizon.

In 2005, the UNEP-SETAC Life Cycle Initiative initiated a comprehensive comparison of the existing methods. The consensus model USEtox is now recommended as the “best” available method by UNEP-SETAC (<http://usetox.org>), and also recommended by EC-JRC for Product Environmental Footprints (PEF) for human toxicity potential. In USEtox, a distinction is made between “interim” and “recommended” characterisation factors (CF). This reflects the different level of reliability of the calculations. CFs for metals are classified as “interim” due to high uncertainty on fate and exposure:

- The mid-point CFs units for HTP are in “Comparative Toxic Unit for Human Health” (CTUh), which estimates the increase in morbidity in the total human population per unit mass of a chemical emitted (i.e. cases per kilogram). Separate “cancer” and “non-cancer” CTUh are provided, but both have default equal weighting, in lack of more precise insights.
- The end-point CF is “Disability-Adjusted Life Years” or “Disease-Adjusted Life Years” (DALY), taking into account the years lost to premature death and expressing the reduced quality of life due to illness in years as well, are also optionally provided. But these entail further assumptions and uncertainties, and are not ISO-compliant for all “comparative assertions intended for public disclosure” (ISO 14,044).

Another methodology developed for human health, e.g. particulate potential (HHPP) is TRACI - Tool for the Reduction and Assessment of Chemical and other environmental Impacts

(<https://www.epa.gov/chemical-research/tool-reduction-and-assessment-chemicals-and-other-environmental-impacts-traci>).

### 2.5.5.2 Abiotic Depletion Potential

The Abiotic Depletion Potential - Minerals & Metals (ADP\_MM) concerns the extraction of scarce minerals. Values are determined for each extraction of minerals based on the remaining reserves and rate of extraction. AD methods mainly differ in terms of time horizon (e.g. focus on long-term depletion potential vs. short-term supply risk), and associated assumptions on reserve bases:

- The CML ADP<sub>ultimate reserves</sub> uses current extraction rates and assumes stock estimates = total crustal contents:
  - Total crustal content is chosen as the best available proxy for “ultimately extractable” reserve, since the latter is a moving target that depends on unknown future technological developments.
  - Mid-point CFs are expressed in terms of kg Antimony equivalent (kg Sb-equivalent).
  - Method was originally developed in 1995, then CFs updated in 2002 and 2019.
  - This method is “recommended” by UNEP/SETAC Life Cycle Initiative, and by EC-JRC.
- ADP<sub>economic reserves</sub> alternatively assumes stock estimates, those that are economically extractable at present:
  - Mid-point CFs are still expressed in terms of kg Sb-equivalent.
  - This method better highlights the more imminent pressure on resource availability.
  - But, it suffers from two main weaknesses:
    - anthropogenic stocks (e.g., secondary sources) are excluded and
    - economic reserve estimates tend to increase over time, leading to potential underestimation of depletion threat.
  - This method is only “suggested” but not officially “recommended” (a much weaker endorsement).

### 2.5.5.3 Water

To assess water related impacts two main methodologies are relevant:

- Water Footprint and
- Water Scarcity.

The Water Footprint Standard is an inventory-level method (<https://waterfootprint.org/en/resources/publications/water-footprint-assessment-manual-global-standard/>).

In the Water Footprint, the water withdrawal is analysed and classified in:

- off stream water use:
  - consumptive use of:



- green water: evaporative from crops/forestry,
- blue water: non-evaporative run-off,
- grey water: additional water required to dilute pollutants to water quality standards,
  - degradative use, released as polluted water and
- in stream water use, released as unpolluted water.

For Water Scarcity, there are two impact assessment methodologies

- Water Stress Index (WSI) and
- Available Water Remaining (AWaRe).

The main aspects of these two impact assessment methodologies are:

- Water Stress Index (WSI):
  - Water stress index is typically defined as the relationship between total water use and water availability. The closer water use is to water supply, the more likely stress will occur in natural and human systems.
  - Regionalised mid-point characterization model is based on withdrawal-to-availability ratio.
  - WSI indicates the portion of  $WU_{\text{consumptive}}$  that deprives other users of freshwater.
  - Further converted to end-point indicators for Ecosystem Quality (EQ) and Human Health (HH), the latter based on competition with irrigation.
  - This indicator has been used by the United Nations and others.
- Available Water Remaining (AWaRe):
  - Regionalised mid-point characterization model is based on withdrawal-to-availability ratio.
  - New consensus method of UNEP/SETAC working group on water use in LCA (WULCA).
  - Suggested by EC-JRC as new standard impact assessment method for water use in PEF.
  - WaterS is an indicator from the AWaRe characterisation model that provides an assessment for water consumption. Units for scarcity-adjusted water use are in  $\text{m}^3$  world eq.

#### 2.5.5.4 Biodiversity

Biodiversity is also much related to land use aspects. The impact assessment methodologies are therefore very complex and still under development e.g.:

- Ongoing efforts of the JRC within dedicated working groups.
- JRC is exploring LCIA methods and approaches addressing impact on biodiversity to be potentially integrated in the environmental footprint method in the future.
- Currently, operational and novel methods addressing impact on biodiversity at the midpoint and endpoint (that take into account different midpoint impacts such as climate change, land use, etc.) are under test by the JRC.
- Key aspect is to judge how these methods can be operable and in line with current inventory phase.



### 2.5.6 Selection of Indicators in LCA for EVs and ICEs

LCA as a system assessment method addresses environmental impacts best on global scale like global warming or resource use. The assessment of regional and local environmental impacts like acidification, human toxicity and biodiversity are depending very much on site-specific local conditions. An inclusion of regional and local impact categories needs a very site-specific inventory in LCA, e.g. in combination with GIS (Geographical information System).

Due to the high need of site-specific data and/or lacking of these data, the regional and local impacts are very difficult to be addressed in practice by LCA or EVs and conventional ICEs today. So further essential developments are needed to cover these impacts in future.

Otherwise, it is also argued that other methodologies than LCA can address these regional and local environmental impacts better; e.g. biodiversity is mainly relevant in agricultural and forestry systems, human toxicity is relevant for quality of life and living conditions.

Due to the methodological complexity and uncertainty, the practical addressing and calculation of end-point indicators are not recommended within experts participating in the workshop for LCA of electric vehicles and conventional vehicles.

The main relevant impacts with current state of impact assessment methodologies using available and robust inventory data in LCA are mainly for global impact categories.

These main global impact categories for transportation systems as discussed in the workshop? are:

- climate change,
- primary energy use (consumption) (fossil and renewable),
- resource use minerals and metals,
- water footprint (inventory level),
- Ozone depletion and
- land use (inventory level).

### 2.5.7 Framework

Taking these six identified global impacts for EVs into account, there are some recommendations concluded for current and future LCA practical application.

The recommendations are split into:

- current minimum requirements and
- future advanced requirements

for global impact assessment of EVs in comparison to other vehicles.

For all considered impacts of course the goal and scope of the LCA is essential.

The results on the considered global impact categories should be documented and communicated not only for the total value but also for the three main phases in the life cycle of a transportation system:

- production:
  - vehicle,
  - energy/battery storage,
- operation:
  - fuel/energy supply,
  - fuel use,
  - maintenance,
- end of life:
  - recycling and/or reuse and
  - substitution of secondary material.

The main influencing parameters on the global impacts should be identified and described.

### 2.5.8 Current Minimum Requirements

The current minimum requirements on LCA for EVs and ICEs should cover global warming and primary energy demand as major relevant global impact categories addressing the key issues of GHG emissions and energy efficiency.

The following should be considered on these two global impact categories:

- Global warming:
  - The Global Warming Potential (GWP) is given in kg CO<sub>2</sub>-eq<sub>100</sub>.
  - The individual greenhouse gases and their CO<sub>2</sub>-equivalent factor should be described, e.g. according to IPCC AR; now also biogenic based CH<sub>4</sub>-emissions have a different equivalent factor than fossil based CH<sub>4</sub> (e.g. from coal mining).
  - The contributions (%) of the most relevant individual greenhouse gases should be documented.
- Primary energy demand:
  - The Primary Energy Demand (PED) is also called Cumulative Energy Demand (CED) or Total Primary Energy (TPE) with analogue meaning.
  - The primary energy demand is given in MJ.
  - It must be specified if the methodology for the PED is based on the lower (LHV) or higher heating value (HHV). The difference might be up to 5%, but there is no general agreement on the type of heating value.
  - Beside the total PED also the share (%) of renewable and fossil and nuclear energy should be described.
  - Optionally, it is also useful especially for EVs to identify the major primary energy carriers used, e.g. coal, natural gas, wind, hydro, solar, nuclear.

### 2.5.9 Future Advanced Requirements

The future advanced requirements for impact assessment address:

- resource use, minerals and metals,
- water footprint (inventory level),
- land use and
- ozone depletion.

For EVs (incl. batteries) and renewable electricity generation the type and amount of material used in the construction phase becomes more relevant than for conventional vehicles using raw oil. Therefore, the impact category of “resource use, mineral and metals” also becomes a more relevant global impact category. Concluding, an advanced requirement for LCA should be to calculate the amount of material in the inventory analysis especially for the most relevant materials like Cu, Li, Co, Ni, Mn and others. Based on the inventory the resource use should be assessed on the basis of kg Sb-eq and giving the main contributions from single minerals or metals.

Water issues are also relevant, especially for mining activities, lithium extraction and hydro power. So on global scale the Water Footprint using the inventory based methodology should be assessed in future LCA of EVs and ICEs.

In addition, land use aspects are relevant for mining of raw materials as well as for renewable electricity production. As a next step in LCA of EVs the amount of land or land occupation over time should be analysed in the inventory phase by at least differentiation on the type of land: agriculture, forestry, infrastructure, industrial area or any other type of land.

The impact category “Ozone Depletion” can easily be addressed in LCA of EVs and ICEs, but seems currently of lower relevance for transportation systems, except from losses of fluids from cooling systems or their end of life treatment.

### 2.5.10 Conclusion and Outlook

The global indicators also cover and address aspects of the two most relevant environmental aspects currently under public and political agenda e.g. within the GreenDeal:

- “Climate neutrality” and
- “Circularity”.

However, as these aspects are relevant in a dynamic system perspective, e.g. recycling to secondary material, further methodological developments are necessary to integrate them in LCA.

Considering current international LCAs on EVs in comparison to ICE, it becomes obvious that global warming and primary energy demand are a minimum requirement and state of the art in impact assessment. LCAs disregarding one of these two impacts are too limited or misleading in their conclusions and interpretations.

It is expected that the other global impacts - Resource Use, Water Footprint and Land Use – will be analysed and assessed in LCA of EVs in future more often, using the rapid international progress made for inventory data.

Considering the local and regional impact categories in LCA, further methodological developments, better inventory data and general acceptance are necessary. Alternatively, these environmental impacts (e.g. biodiversity) will be addressed with other methodologies than LCA more adequate in future.

The new IEA HEV TCP Task 46 (2022 – 2024) “LCA of electric Trucks, Buses, 2-Wheelers and other Vehicles” will address these global impact categories further and intends to develop and discuss new approaches to address “Climate Neutrality” and “Circularity” of transportation systems in (dynamic) LCA.

## 2.6 Rebound Effects of EVs and Possible Implication on LCA

### 2.6.1 Introduction

The introduction of electric vehicles globally is ongoing very fast. Currently, there are about 7.2 Mio. electric passenger vehicles (EV) in about 100 countries on the road (IEA 2020). The main share of this EV-fleet, which includes about 65% BEVs and 35% PHEVs, is in China, USA and Norway. The key drivers for the introduction of EVs are improvement of air quality in cities and reduction of GHG emission to reach the Paris Climate agreement. The overall improvements are determined by the environmental effects of EVs in the overall lifecycle including production, operation and end of life, which is done with the methodology of LCA. The main environmental issues in the lifecycle of an EV are the production of battery and the source of the electricity needed for driving.

Additionally, the overall environmental benefits depend on the number and type of substituted conventional vehicles with an ICE using diesel or gasoline.

As the global stock of passenger vehicles is still growing and the annual driving distance of each vehicle is still increasing, it becomes evident that not each EV is substituting an ICE vehicle in reality. Also the different daily use of an EV might be different compared to an ICE vehicle, the topic addressed in this document is, to estimate how many electric driven kilometres of an EV are substituting fossil driven kilometres by an ICE vehicle to reduce the annual and lifetime environmental impacts.

These possible substitution effects are called “rebound effects” which are described and analysed in this document and then the possible influence or integration of the rebound effects in LCA (Life Cycle Assessment) of EVs are analysed and discussed.

### 2.6.2 Types and Dynamics of Rebound

Many countries are relying on innovative, energy-efficient technologies to achieve climate targets (OECD 2010). Lowering energy use per unit output is an attractive option to reduce energy demand and to combat carbon emissions (IEA 2014). The strategy of advancing energy-efficient technologies is successful, if the gain in technical efficiency is not (over-)compensated by a gradual change in use, the

so called rebound effect (or: takeback effect; Sorrell 2007). Thus, rebound is highly relevant for funding programs, policy strategies and innovation initiatives, which aim to account for the far-reaching transformative impacts of mobility innovations (Font Vivanco et al. 2016). If expected savings are obtained only partially due to rebound, the achievement of energy and climate targets is compromised. However, rebound may also be desirable, if the efficiency gain leads to cheaper resource use and consequently increases in economic growth and welfare (IEA 2014).

Commonly, three types of rebound effects are differentiated (Sorrell 2007, Santarius 2014, Gillingham et al. 2016). However, system boundaries between the three types overlap to a certain degree (Figure 9):

- *Direct rebound:* Consumer demand increases when improving efficiency makes the provision of a product or service cheaper. Direct rebound happens within the same consumption domain, e.g. former cycling trips are shifted to the electric car, or the overall number and length of trips increases.
- *Indirect rebound:* Income freed up by efficiency gains is spent for other energy-consuming products and services, or consumption in other domains is shifted to the now cheaper service. Indirect rebound involves redistribution between different consumption domains.
- *Economy-wide rebound:* Feedback effects from supply and demand adjustment processes accumulate across all economic sectors. Economy-wide rebound leads to an overall increase in energy use within an economy.

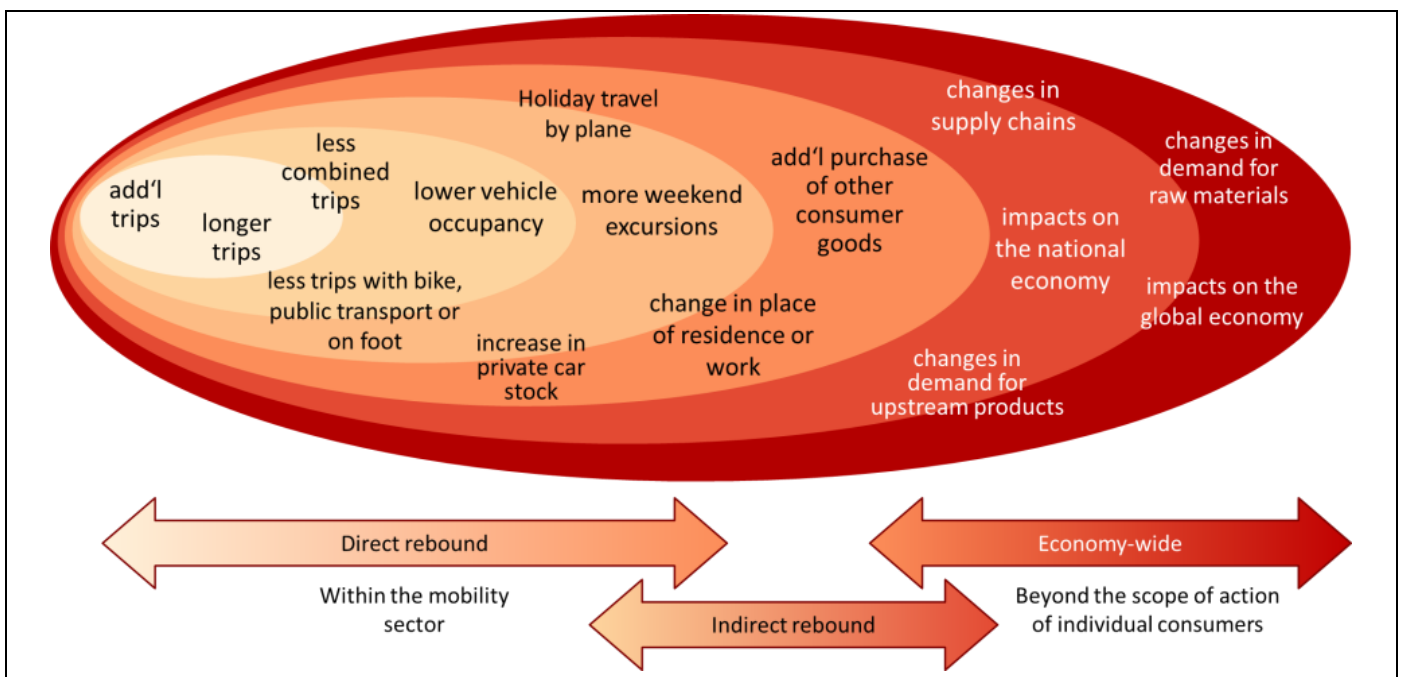

Figure 9: System boundaries between direct, indirect, and economy-wide rebound. (Source?)

Rebound emerges from consumers balancing their actions within and between consumption domains (Santarius & Soland 2018). In the prevailing economic view, households reallocate their available

income according to price changes; this logic is not restricted to monetary savings, but applies similarly to savings in time and comfort (Boulanger et al. 2013). Consumers may also engage in mental accounting (or: moral licensing), distributing a personal allowance of moral credits and debits (Miller & Effron 2010). After purchasing an electric car, one has the feeling of having already made an ecological contribution. Now one can indulge oneself in other consumption domains without a guilty conscience (Friedrichsmeier & Matthies 2015).

### 2.6.3 Magnitude of Rebound Effects

Rebound is calculated as the discrepancy between expected and realised efficiency gains. A rebound of 0% means that expected savings are fully achieved in practice. A rebound of 100% means that the entire efficiency gain is compensated by increased use. To avoid conceptual ambiguity, rebound calculations should refer to changes in consumption patterns, and should control for overly optimistic savings expectations (Sunikka-Blank & Galvin 2012), for technical faults and difficulties in the field (Friedrichsmeier & Matthies 2015), and for parallel processes such as fuel costs, changes in household structure, or changes in workplaces (Galvin 2014). There is wide variability in the exact rebound definitions and the methods applied, which leads to high uncertainties (van den Bergh 2011, Turner 2013). Most rebound estimates in passenger transport refer to changes in vehicle mileage per litres fuel as an indicator of the demand for the energy service of undertaking everyday mobility (Sorrell et al. 2009). Stapleton et al. (2016) find only marginal differences when basing the rebound estimate on passenger kilometres instead of vehicle kilometres (to control for vehicle occupancy/load).

Most review studies agree on a direct rebound estimate of 10-30% in fossil-fuel powered propulsion technologies for personal automotive transport. In other words, up to 30% of expected direct savings are not achieved in practice. Differences between countries may be traced back to differences in alternative transport options and fuel prices (Gillingham et al. 2016). Rebound is typically higher in developing than in developed countries (van den Bergh 2011, Jenkins et al. 2011). There are no dedicated electric car rebound studies available. Most rebound studies address fuel-efficient conventional cars, because data on vehicle travel and fuel consumption are routinely collected by governmental authorities (Stapleton et al. 2016).

Table 1: Direct rebound in personal automotive transport.

Study	Country	Direct rebound
Sorrell (2007), Sorrell et al. (2009), Jenkins et al. (2011), Madlener & Alcott (2011), Maxwell et al. (2011), IEA (2014)	OECD countries (review)	10-30% range 5-87%
Greening et al. (2000)	USA (review)	10-30%
Thomas & Azevedo (2013)	USA (review)	3-22%
Gillingham et al. (2016)	USA (review)	5-25% range 4-34%
Gillingham et al. (2016)	Developing countries (review)	10-40% range 9-62%
Greene et al. (1999)	USA	23%
Small & van Dender (2007)	USA	2-11%
Su (2012)	USA	11-19%
Linn (2013)	USA	20-40%
Chitnis et al. (2014)	United Kingdom	25-65%
Stapleton et al. (2016)	United Kingdom	19% range 9-36%
Frondel et al. (2012)	Germany	57-62%
Odeck & Kjell (2016)	Norway	11-23%
Wang et al. (2012)	Urban China	96% range 2-246%

Direct rebound stems from how adopters of electric cars adjust their private vehicle stock (e.g. whether the e-car substitutes an existing car or is purchased as a second/third car), as well as how much and how often they use their e-car (mileage and modal share). Results on adjustments of the private vehicle stock are inconclusive and vary between countries: In Germany, 59% of the buyers of electric cars and 41% of the buyers of hybrid cars purchased the vehicle in addition to their existing car fleet (Frenzel et al. 2015). In a similar vein, in Norway, 91% of electric car buyers own two or more cars, whereas only 51% of normal car buyers do so (Klößner et al. 2013). In contrast, 86% of Swiss hybrid car buyers replaced an old car (de Haan et al. 2006), and only 12 - 23% of Austrian electric car buyers acquired the electric vehicle in addition to their existing conventional cars (VCÖ 2018).

Evidence regarding everyday use is mixed as well: The mileage of German hybrid cars is smaller than of conventional cars (de Haan 2009). Californian hybrid car drivers increased their mileage by just 0.5%



(Afsah & Salcito 2012). Contrastingly, Japanese hybrid car drivers drove 1.6 times farther per year than with their previous vehicle (Ohta & Fujii 2011). Regarding modal share, Norwegian electric car users broadly substitute other transport modes such as public transport with the electric car (Klößner et al. 2013, Holtsmark & Skonhoft 2014).

Besides direct rebound, indirect and economy-wide rebound also merit consideration. Indirect rebound in passenger transport amounts to 5-50% (Jenkins et al. 2011, Madlener & Alcott 2011, IRGC 2013, Thomas & Azevedo 2013). Estimates of economy-wide rebound originating from the transport sector span an even wider range from 20% to 300% (Allan et al. 2007, Turner 2009, Guerra & Sancho 2010), with most estimates around 20-60% (Jenkins et al. 2011, Gillingham et al. 2013). Santarius (2012) suggests as ‘fifty-fifty’ rule of thumb that at least half of expected efficiency gains are compensated in the long run.

#### 2.6.4 LCA of EVs and Rebound Effects

In LCA of EVs and conventional ICE vehicles the environmental effects are given for the functional unit of 1 driven kilometre, in comparison to other transportation modes like buses, trains and trams the functional unit is often per passenger kilometre. Depending on the goal and scope of the LCA, also the annual environmental effects or the cumulated effects over the lifetime are relevant.

LCA methodology according to ISO 14,040 defines the functional unit as the basis for comparison of environmental effects of different systems, which provides the same service or function. Therefore, in the comparison based LCA it is assumed that the functional unit or service of a system can be provided and substituted by another system. However, due to the rebound effects described above it is possible that a system A cannot substitute for a system B for 100%. That is why in LCA of EVs especially for EV fleets it must be proven that no rebound effects are possible, or rebound effects have to be considered.

The possible rebound effect can be considered in LCA by the definition of the functional unit and the substitution rate. In reflecting possible rebound effects in comparing the environmental effects of EVs with conventional ICE vehicles the following issues are relevant and have to be analysed and described referring to possible different uses of the vehicles:

- number of substituted ICE vehicles,
- substituted other transportation modes e.g. public transport, walking,
- different annual mileage,
- vehicle lifetime and
- driving distance with one charging or refill.

These aspects must be considered carefully by defining the functional unit. The possible conclusion might be that the substitution rate is not 100%; it could be in most cases less than 100% but in specific cases also more than 100%, saying that 1 electric driven kilometre substitutes more than 1 fossil ICE driven kilometre.

The consideration of possible rebound effects in LCA of EVs to substitute for ICE vehicles should cover the following practical observed issues:



- energy costs for electricity compared to fossil fuels are lower because of taxation:
  - direct rebound effect: drive more because of lower energy cost,
  - indirect rebound effect: consume more because money is saved,
- higher investment costs of EV might lead to more driving to be more economic,
- EVs are seen to be „green“:
  - Germany: EVs drive 2 – 3 times more than average ICE,
  - Austria: EVs drive 30% more than average ICEs,
  - use EV instead of walking, biking and public transport and
- EVs become 2<sup>nd</sup> or 3<sup>rd</sup> car in households.

The analysis of these issues should be documented in LCA to argument for the chosen substitution rate.

Current experiences in considering rebound effects in LCA show that these are most relevant by considering environmental effects of whole vehicle fleets over time and future scenarios for the development of environmental benefits of EVs in scenarios for transportation services and or mobility systems. In these cases, the influence of possible rebound effects have to be reflected in LCA. A recommendation for practical application is to make sensitivity analyses on various substitution rate to identify the order of magnitude on the final results.

### 2.6.5 Recommendations

Given the observed level of rebound effects, there is an urgent need to include rebound dynamics in energy scenarios and in projections of policy impacts. It seems overly optimistic to assume that efficiency gains will be fully realised in practice. More realistic calculations should instead include a rebound buffer in the expected savings. A rebound buffer of 15% is already implemented in the US Corporate Average Fuel Economy Standards (NHTSA 2009) and the British CERT programme for building retrofitting (Maxwell et al. 2011). However, 15% is most likely the lower bound of rebound effects, which might appear from market and consumption adjustments in the long run.

Ongoing policy initiatives should be screened and subsequently re-designed in regards to their rebound risk. For instance, subsidies for fuel-efficient cars increased new car sales in the Netherlands and in France by 4-8% (EEA 2018). European regulation on carbon emissions from light duty vehicles is associated with rebound effects of up to 60% (Gibson et al. 2015).

More comprehensive instruments for combating rebound are ecological taxes, low carbon product standards or emission caps spanning all consumption domains (Font Vivanco et al. 2016). Taxes take away the additional purchasing power gained from increased efficiency and therefore restrict an increase in material and CO<sub>2</sub>-intensive consumption. If product standards apply to many areas of consumption, the proportion of fossil fuels used in the production of products and services decreases; as a result, indirect rebound from shifting to other consumption domains would be less carbon intensive. Individual emission caps, such as an annual personal carbon budget, would steer consumers towards low-carbon products and services. For counteracting rebound in the long run, the current material growth paradigm needs to be reconceptualised towards decarbonisation of the economy and the society.

Still, despite of rebound risk, energy efficiency remains a critical pillar for achieving energy and climate targets. It would be short-sighted to forgo efficiency measures just because they might be partially undercut by rebound. Instead, policymakers, businesses and consumers should jointly strive to reduce rebound so to leverage the full potential of energy efficiency improvements.

## 2.6.6 References

- Afsah, S., Salcito, K. (2012). Non-conundrum of the Prius Fallacy. CO<sub>2</sub> Scorecard Research Note. <http://co2scorecard.org/home/researchitem/23>
- Allan, G., Hanley, N., McGregor, P., Swales, K., Turner, K. (2007). The impact of increased efficiency in the industrial use of energy: A computable general equilibrium analysis for the United Kingdom. *Modeling of Industrial Energy Consumption*, 29(4), 779–98. doi:10.1016/j.eneco.2006.12.006.
- van den Bergh, J. (2011). Energy conservation more effective with rebound policy. *Environmental and Resource Economics*, 48(1), 43-58. doi:10.1007/s10640-010-9396-z.
- Boulangier, P.-M., Couder, J., Marenne, Y., Nemoz, S., Vanhaverbeke, J., Verbruggen, A., Wallenborn, G. (2013). Household Energy Consumption and Rebound Effect. Final report to the Research Programme Science for a Sustainable Development. Belgian Science Policy, Brussels. doi:10.13140/RG.2.1.3515.3361.
- Chitnis, M., Sorrell, S., Druckman, A., Firth, S., Jackson, T. (2014). Who rebounds most? Estimating direct and indirect rebound effects for different UK socioeconomic groups. *Ecological Economics*, 106, 12-32. doi:10.1016/j.ecolecon.2014.07.003.
- EEA European Environment Agency (2018). Vehicle Emissions and Impacts of Taxes and Incentives in the Evolution of Past Emissions. Eionet Report - ETC/ACM 2018/1. [http://acm.eionet.europa.eu/reports/docs/EIONET\\_Rep\\_ETCACM\\_2018\\_1\\_Vehicle\\_Taxes.pdf](http://acm.eionet.europa.eu/reports/docs/EIONET_Rep_ETCACM_2018_1_Vehicle_Taxes.pdf)
- Font Vivanco, D., Kemp, R., van der Voet, E. (2016). How to deal with the rebound effect? A policy-oriented approach. *Energy Policy*, 94, 114-125. doi:10.1016/j.enpol.2016.03.054.
- Frenzel, I., Jarass, J., Trommer, S., Lenz, B. (2015). Erstnutzer von Elektrofahrzeugen in Deutschland. Nutzerprofile, Anschaffung, Fahrzeugnutzung. [http://elib.dlr.de/96491/1/Ergebnisbericht\\_E-Nutzer\\_2015.pdf](http://elib.dlr.de/96491/1/Ergebnisbericht_E-Nutzer_2015.pdf)
- Frondel, M., Ritter, N., Vance, C. (2012). Heterogeneity in the rebound effect: Further evidence for Germany. *Energy Economics*, 34(2), 461-467. doi:10.1016/j.eneco.2011.10.016.
- Friedrichsmeier, T., Matthies, E. (2015). Rebound Effects in Energy Efficiency – an Inefficient Debate? *GAIA*, 24(2), 80-84. doi:10.14512/gaia.24.2.3..
- Galvin, R. (2014). Making the ‘rebound effect’ more useful for performance evaluation of thermal retrofits of existing homes: Defining the ‘energy savings deficit’ and the ‘energy performance gap’. *Energy and Buildings*, 69, 515-524. doi:10.1016/j.enbuild.2013.11.004.

Gibson, G., Kollamthodi, S., Kirsch, F., Windisch, E., Brannigan, C., White, B., Bonifazi, E., Korkeala, O., Skinner, I. (2015). Evaluation of Regulation 443/2009 and 510/2011 on CO2 emissions from light-duty vehicles. Final Report. doi:10.2834/64489.

Gillingham, K., Kotchen, M., Rapson, D., Wagner, G. (2013). The rebound effect is overlaid. *Nature*, 493, 475-476. doi:10.1038/493475a.

Gillingham, K., Rapson, D., Wagner, G. (2016). The Rebound Effect and Energy Efficiency Policy. *Review of Environmental Economics and Policy*, 10(1), 68-88. doi:10.1093/reep/rev017.

Greene, D., Kahn, J., Gibson, R. (1999). Fuel economy rebound effect for US household vehicles. *The Energy Journal*, 20(3), 1-31.

Greening, L., Greene, D., Difiglio, C. (2000). Energy efficiency and consumption – the rebound effect – a survey. *Energy Policy*, 28(6-7), 389-401. doi:10.1016/S0301-4215(00)00021-5.

Guerra, A.-I., Sancho, F. (2010). Rethinking economy-wide rebound measures: An unbiased proposal. *Energy Efficiency Policies and Strategies with regular papers*, 38(11), 6684–94. doi:10.1016/j.enpol.2010.06.038.

de Haan, P., Mueller, M., Peters, A. (2006). Does the hybrid Toyota Prius lead to rebound effects? Analysis of size and number of cars previously owned by Swiss Prius buyers. *Ecological Economics*, 58, 592-605. doi:10.1016/j.ecolecon.2005.08.009.

de Haan, P., Mueller, M., Scholz, R. (2009). How much do incentives affect car purchase? Agent-based microsimulation of consumer choice of new cars, part II: Forecasting effects of feebates based on energy-efficiency. *Energy Policy*, 37, 1083–1094. doi:10.1016/j.enpol.2008.11.003.

Holtmark, B., Skonhoft, A. (2014). The Norwegian support and subsidy policy of electric cars. Should it be adopted by other countries? *Environmental Science & Policy*, 42, 160-168. doi:10.1016/j.envsci.2014.06.006.

IEA International Energy Agency (2014). Capturing the Multiple Benefits of Energy Efficiency. OECD/IEA, Paris. [http://www.iea.org/publications/freepublications/publication/Multiple\\_Benefits\\_of\\_Energy\\_Efficiency.pdf](http://www.iea.org/publications/freepublications/publication/Multiple_Benefits_of_Energy_Efficiency.pdf)

IEA 2020: Global EV Outlook 2020 - Entering the decade of electric drive?, [www.iea.org](http://www.iea.org)

IRGC International Risk Governance Council (2013). The Rebound Effect: Implications of Consumer Behaviour for Robust Energy Policies. [http://www.irgc.org/wp-content/uploads/2013/04/IRGC\\_ReboundEffect-FINAL.pdf](http://www.irgc.org/wp-content/uploads/2013/04/IRGC_ReboundEffect-FINAL.pdf).

Jenkins, J., Nordhaus, T., Shellenberger, M. (2011). Energy Emergence. Rebound & Backfire as Emergent Phenomena, Breakthrough Institute. [https://thebreakthrough.org/blog/Energy\\_Emergence.pdf](https://thebreakthrough.org/blog/Energy_Emergence.pdf)

Jungmeier et al. 2019: Gerfried Jungmeier, Lorenza Canella, Jarod C. Kelly, Amgad A. Elgowainy, Simone Ehrenberger, Deidre Wolff: Evaluation of the Environmental Benefits of The Global EV-Fleet in 40 Countries – A LCA Based Estimation in IEA HEV, EVS32 – Electric Vehicle Symposium Lyon, France, May. 19 – 22, 2019

Jungmeier et al. 2019a: Gerfried Jungmeier, Lorenza Canella, Amgad A. Elgowainy, Simone Ehrenberger, Gabriela Benveniste Perez, Pierre-Olivier Roye, Lim Ocktaeck, Tugce Yuksel: Time and Rebound Effects in the LCA of Electric Vehicles - Methodological Approach and Examples, IEWT 2019, Vienna University of Technology, Vienna, Austria, February 13 – 15, 2019

Klößner, C., Nayum, A., Mehmetoglu, M. (2013). Positive and negative spillover effects from electric car purchase to car use. *Transportation Research Part D: Transport and Environment*, 21, 32-38. doi:10.1016/j.trd.2013.02.007.

Linn, J., (2013). The rebound effect for passenger vehicles. Resources for the Future Discussion Paper. <http://www.rff.org/files/sharepoint/WorkImages/Download/RFF-DP-13-19.pdf>

Madlener, R., Alcott, B. (2011). Herausforderungen für eine technisch-ökonomische Entkopplung von Naturverbrauch und Wirtschaftswachstum. Unter besonderer Berücksichtigung der Systematisierung von Rebound-Effekten und Problemverschiebungen. Bericht für die Enquete-Kommission „Wachstum, Wohlstand, Lebensqualität“ des Deutschen Bundestages. <http://webarchiv.bundestag.de/archive/2013/1212/bundestag/gremien/enquete/wachstum/gutachten/m17-26-13.pdf>

Maxwell, D., Owen, P., McAndrew, L., Muehmel, K., Neubauer, A. (2011). Addressing the Rebound Effect. A Report for the European Commission DG Environment. [http://ec.europa.eu/environment/archives/eussd/pdf/rebound\\_effect\\_report.pdf](http://ec.europa.eu/environment/archives/eussd/pdf/rebound_effect_report.pdf)

Miller, D., Effron, D. (2010). Psychological license. When it is needed and how it functions. *Advances in Experimental Social Psychology*, 43, 115-155. doi:10.1016/S0065-2601(10)43003-8.

NHTSA National Highway Traffic Safety Administration (2009). Average Fuel Economy Standards for Passenger Cars and Light Trucks, Model Year 2011. Docket No. NHTSA-2009-0062. <https://www.gpo.gov/fdsys/pkg/FR-2009-03-30/pdf/E9-6839.pdf>

Odeck, J., Kjell, J. (2016). Elasticities of fuel and traffic demand and the direct rebound effects: An econometric estimation in the case of Norway. *Transportation Research Part A*, 83, 1-13. doi:10.1016/j.tra.2015.10.003.

OECD Organisation for Economic Co-operation and Development (2010). Low-emission development strategies (LEDS): technical, institutional and policy lessons. Paris. <http://www.oecd.org/env/cc/46553489.pdf>

Ohta, H., Fujii, S. (2011). Does purchasing an “eco-car” promote increase in car-driving distance. Tokyo Institute of Technology.

Santarius, T. (2012). Der Rebound-Effekt. Über die unerwünschten Folgen der erwünschten Energieeffizienz. Impulse zur Wachstumswende. Wuppertal Institut für Klima, Umwelt, Energie GmbH, Wuppertal. <https://epub.wupperinst.org/frontdoor/deliver/index/docId/4219/file/ImpW5.pdf>

Santarius, T. (2014). Der Rebound-Effekt: ein blinder Fleck der sozial-ökologischen Gesellschaftstransformation. *GAIA*, 23(2), 109-117. doi:10.14512/gaia.23.2.8.

Santarius, T., Soland, M. (2018). How Technological Efficiency Improvements Change Consumer Preferences: Towards a Psychological Theory of Rebound Effects. *Ecological Economics*, 146, 414-424. doi:10.1016/j.ecolecon.2017.12.009.

Small, K., van Dender, K. (2007). Fuel Efficiency and Motor Vehicle Travel: The Declining Rebound Effect. *The Energy Journal*, 28(1), 25-51. www.jstor.org/stable/41323081.

Sorrell, S. (2007). The Rebound Effect: an assessment of the evidence for economy-wide energy savings from improved energy efficiency. UK Energy Research Centre Report. <http://www.ukerc.ac.uk/asset/3B43125E-EEBD-4AB3-B06EA914C30F7B3E/>

Sorrell, S., Dimitropoulos, J. Sommerville, M.. (2009). Empirical estimates of the direct rebound effect: A review. *Energy Policy*, 37, 1356-1371. doi:10.1016/j.enpol.2008.11.026.

Stapleton, L., Sorrell, S., Schwanen, T. (2016). Estimating direct rebound effects for personal automotive travel in Great Britain. *Energy Economics*, 54, 313-325, doi:10.1016/j.eneco.2015.12.012.

Su, Q. (2012). A quantile regression analysis of the rebound effect: evidence from the 2009 national household transportation survey in the United States. *Energy Policy*, 45, 368–377. doi:10.1016/j.enpol.2012.02.045.

Sunikka-Blank, M., Galvin, R. (2012). Introducing the prebound effect: the gap between performance and actual energy consumption. *Building Research & Information*, 40(3), 260-273. doi:10.1080/09613218.2012.690952.

Thomas, B., Azevedo, I. (2013). Estimating direct and indirect rebound effects for U.S. households with input–output analysis. Part 2: Simulation. *Ecological Economics*, 86, 188–198. doi:10.1016/j.ecolecon.2012.12.002.

Turner, K. (2009). Negative rebound and disinvestment effects in response to an improvement in energy efficiency in the UK economy. *Energy Economics*, 31(5), 648–666. doi:10.1016/j.eneco.2009.01.008.

Turner, K. (2013). “Rebound” effects from increased energy efficiency. A time to pause and reflect. *The Energy Journal*, 34(4), 25-42. doi:10.5547/01956574.34.4.2.

VCÖ Verkehrsclub Österreich (2018). Rebound- und Seiten-Effekte im Verkehrssystem. VCÖ-Schriftenreihe Mobilität mit Zukunft 2018-02. <https://www.vcoe.at/publikationen/vcoe-schriftenreihe-mobilitaet-mit-zukunft/detail/rebound-und-seiten-effekte-im-verkehrssystem>

Wang, H., Zhou, P., Zhou, D. (2012). An empirical study of direct rebound effect for passenger transport in urban China. *Energy Economics*, 34(2), 452–460. doi:10.1016/j.eneco.2011.09.010.

## 2.7 Evaluation of the Environmental Benefits of the Global EV-Fleet in 38 Countries

### 2.7.1 Goal and Scope

Conventional vehicles with an ICE contribute significantly to global and local environmental effects. The development of a more sustainable mobility worldwide is a key challenge for society, industry and policy. EVs might substantially contribute to a sustainable development in the transport sector, e.g. reduction of GHG and particulate matter (PM) emissions, if adequate framework conditions to maximize the environmental benefits are considered.

The method of LCA – analyzing and assessing environmental effects from manufacturing, operation and end of life management in the whole life cycle of a transportation system – has been developed and used since more than 25 years. Today, it is state of the art that the environmental effects can only be estimated based on the LCA methodology, which is recognized by industry, government and relevant stakeholder groups, e.g. NGOs.

The IEA has a TCP on HEVs, in which currently 18 countries cooperate. In this TCP, a collaboration of international experts on the LCA of Electric Vehicles developed a methodology and a database to estimate the environmental effects of the growing worldwide electric vehicle fleet of about 5 million BEVs and PHEVs in 38 countries.

An LCA is made by analyzing and assessing the country specific framework conditions with a special focus on national electricity production for the electric vehicles. Based on the LCA the following environmental effects of the vehicle fleets are estimated in reasonable ranges:

- greenhouse gas emissions (CO<sub>2</sub>, CH<sub>4</sub>, N<sub>2</sub>O) in CO<sub>2</sub>-eq,
- acidification (NO<sub>x</sub>, SO<sub>2</sub>) in SO<sub>2</sub>-eq, divided in local emissions from vehicle operation and global emissions,
- ozone formation (NO<sub>x</sub>, CO, NMVOC, CH<sub>4</sub>) in C<sub>2</sub>H<sub>4</sub>-eq,
- particulate matter emissions in PM, divided in local emissions from vehicle operation and global emissions and
- primary energy consumption (total, fossil, nuclear, renewable).

A comparison of these environmental effects to those of conventional ICE vehicles is done. The system boundary chosen for the LCA is shown in [Figure 10](#) and covers the following main stages in the life cycle starting in nature with the extraction of necessary raw materials and primary energy carriers to the supply of a transportation service in the three phases (manufacturing, operation and end of life management of the vehicle):

- production of the vehicle and the battery,
- electricity production in different power plants,
- transmission of the electricity by the electricity grid,
- charging infrastructure,
- use of electric vehicle and



- end of life management via material recovery and/or energy generation.

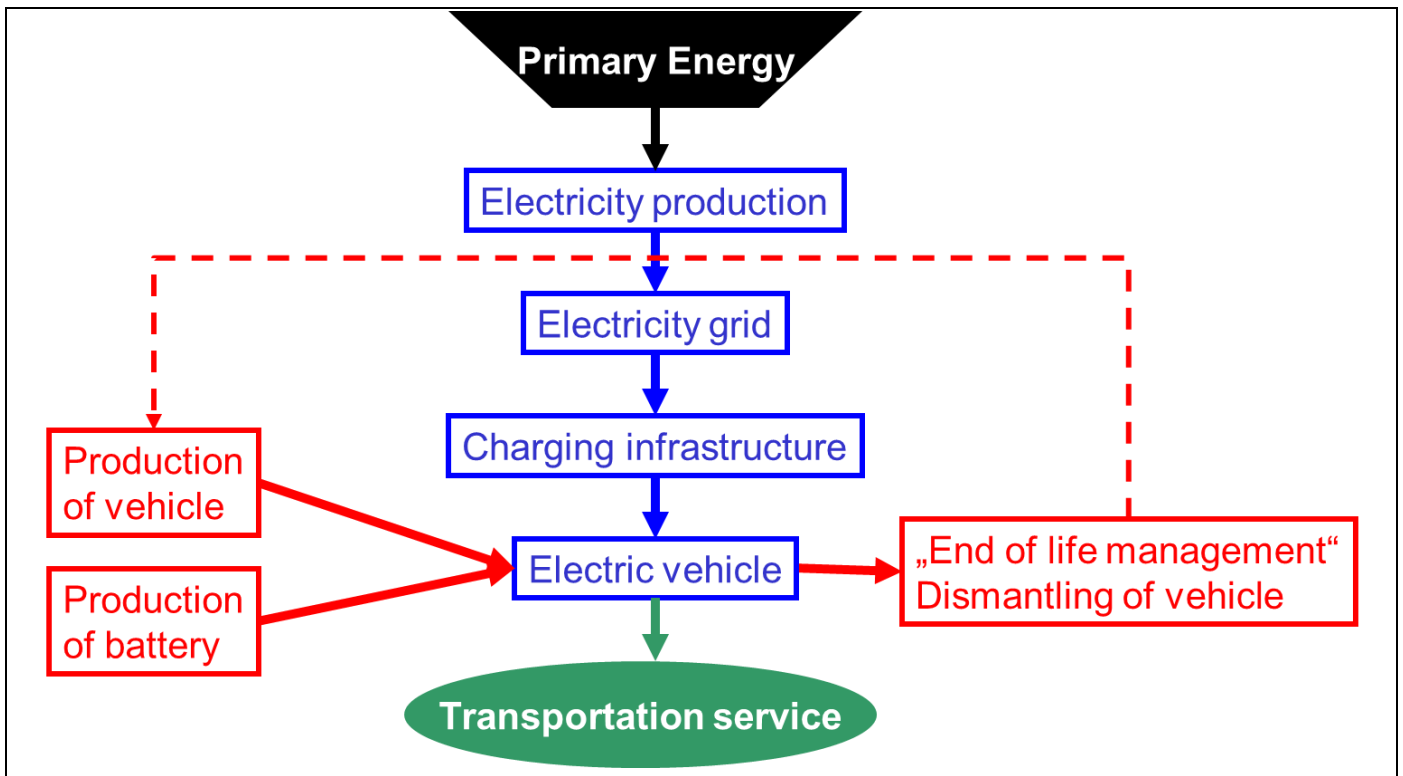

Figure 10: LCA system boundary

The analysis is done for each of the 38 countries separately from 2014 to 2018. The 38 countries are Austria, Australia, Belgium, Brazil, Bulgaria, Canada, Chile, China, Czech Republic, Denmark, Finland, France, Germany, Greece, Hungary, India, Ireland, Italy, Japan, Luxembourg, Mexico, Netherlands, New Zealand, Norway, Poland, Portugal, Republic of Korea, Romania, Slovakia, Slovenia, South Africa, Spain, Sweden, Switzerland, Thailand, Turkey, United Kingdom, and United States. Then the country specific results are added up to the global fleet of EVs, where two subgroups of countries are distinguished: the 18 “IEA HEV countries” (AT, BE; CA, CH, DE, DK, ES, FI, FR, IR, IT, KR, NL, NO, SE, TU, UK, US) and the 20 “Non IEA HEV countries”.

In a so called “Country Factsheet on Estimated Environmental Impacts of Current EV-Fleet” the main data and results are summarized for each country:

- “Basic data” on electricity generation and size of electric vehicle fleet,
  - share of generation technologies supplying the national electricity grid,
  - estimated environmental effects of electricity at charging point,
  - current situation and future development of national electricity market (incl. import & export),
  - size of electric vehicle fleet: number of BEV and PHEV,
- “Estimation of LCA based environmental effects” by substituting conventional ICE,

- absolute annual change,
- relative annual change (referring to substituted ICE vehicles).

The international group of experts developed the methodology for the LCA of EV fleets in IEA HEV Task 30 “Environmental Effects of EVs” (since 2011). The LCA methodology is documented and published in [1-4]. An analysis of the possible future environmental effects of a growing fleet of EV, based on scenario analysis, is not considered in this work, as only the development and the existing EV fleet is considered.

### 2.7.2 Basic Data and Assumptions

There are approximately 5 million electric vehicles in 38 countries worldwide in 2018 [7, 8], of which

- 3.2 million are BEVs and 1.8 million are PHEVs
- 45% are located in China, 22% in the USA, 5% in Japan and 5% in Norway in 2018 (Figure 11).

It is expected that the EV fleet will grow further, but a scenario development of the global EV fleet under different conditions is not part of this activities in the IEA HEV Task 30.

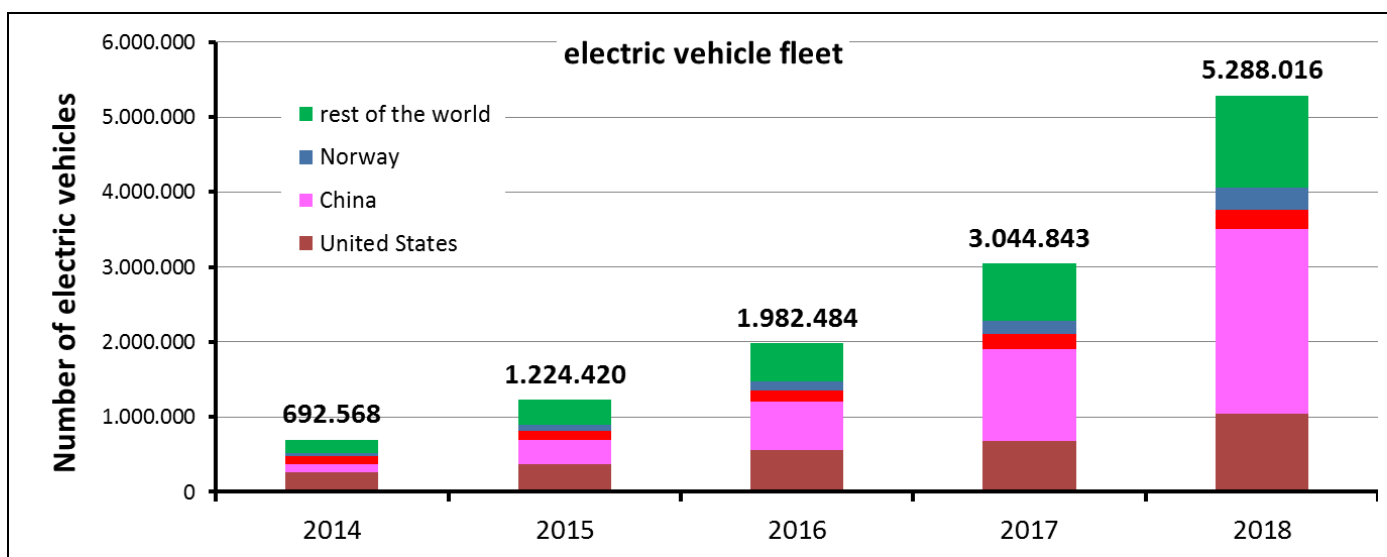

Figure 11: Vehicle fleet worldwide 2014 – 2018 [7, 8]

In Table 2 the main vehicle data used in the analysis are shown, where the energy consumption of the vehicle is given in a reasonable range, which is used in the calculation. In Table 3 the environmental data of the vehicles and in Table 4 the equivalent factors of environmental impacts are given.



Table 2: Main vehicle data

		BEV	PHEV	ICE	remark
<b>consumption</b>					
	electricity [kWh/km]	0.21 - 0.23	0.21 - 0.23	-	1)
	fuel [kWh/km]	-	0.44 - 0.49	0.49 - 0.54	2), 3)
<b>annual kilometres</b>					
	electricity [km/a]	14.000	9.100	-	4), 5)
	fuel [km/a]	-	4.900	14.000	
1) incl. 15% charging losses and aux. energy for heating/cooling					
2) PHEV: in ICE-HEV mode 10% more efficient than ICE, in US and CA: 40%					
3) ICE in USA and CA: 0.78 kWh/km (average)					
4) annual kilometres USA and CA: 19,200 km/a					
5) electric driven km of PHEV in USA&CA: 15,350 km/a; NL: 4,200 km/a					

Table 3: Environmental data of vehicles

	emissions				primary energy				remark
	CO <sub>2</sub> -eq.	SO <sub>2</sub> -eq.	C <sub>2</sub> H <sub>4</sub> -eq	PM	fossil	renewable	nuclear	total	
	[g/km]	[g/km]	[g/km]	[g/km]	[kWh/km]	[kWh/km]	[kWh/km]	[kWh/km]	
EV (production&dismantling)	55 - 61	0.07 - 0.08	0.04 - 0.04	0.004 - 0.004	0.15 - 0.16	0.03 - 0.03	0.03 - 0.03	0.18 - 0.2	
ICE vehicle (production, operation&dismantling)	220 - 243	0.1 - 0.1	0.4 - 0.4	0 - 0	0.62 - 0.68	0.06 - 0.07	0.06 - 0.07	0.68 - 0.75	1)
1) ICE in USA and CA different, e.g. 290 g CO <sub>2</sub> -eq/km									

Table 4: Equivalent factors of environmental impacts

GWP	CO <sub>2</sub> -eq	Acidification	SO <sub>2</sub> -eq	Ozon formation	C <sub>2</sub> H <sub>4</sub> -eq
CO <sub>2</sub>	1	SO <sub>2</sub>	1	NMVOG	1
CH <sub>4</sub>	34	NO <sub>x</sub>	0.7	CH <sub>4</sub>	0.014
N <sub>2</sub> O	298			NO <sub>x</sub>	1.22
				CO	0.11

The application of LCA to whole EV fleets must consider possible rebound effects to avoid an overestimation of the environmental benefits. Research on possible rebound effects of the broad introduction of EVs show that not each driven kilometre by an EV substitutes an ICE driven kilometre. The most relevant rebound effects identified are that EVs increase the global car fleet as EV become 2<sup>nd</sup> or 3<sup>rd</sup> vehicle in households and EVs substitute public transport, walking and cycling. The IEA task 30 analysed these possible rebound effects and estimated that, on average, an EV substitutes about 85% of ICE driven kilometres [6].

The main assumptions, derived from expert consultation and workshop discussions in the IEA HEV Task, in the LCA of EVs and ICE vehicles are:

- Grid losses: 5% - 7% from power plants to charging point.
- The average European electricity mix with 7% grid distribution losses is assumed for imported electricity in European countries.
- The charging energy losses are assumed to be 15%.
- Substitution rate: 85% of the ICE vehicle driven kilometres is substituted by electric driven kilometres (BEV and PHEV).
- The vehicles (ICE, BEV, and PHEV) are assumed to be generic middle-sized class vehicles (e.g. “VW Golf class”) for all considered countries (except USA and CA).
- The environmental effects of vehicle production and dismantling are generic for all countries; a differentiation based on the region where they are produced cannot be made.
- Lifetime for all vehicles (and battery for EVs) is 10 years.
- The GHG emissions of the battery production (incl. recycling of materials) are estimated between 35 – 50 g CO<sub>2</sub>-eq/km-. However, further reductions are expected in future due to the increase of the global production volumes of automotive batteries realising economy of scale effects on energy efficiency and a higher share of renewable electricity use in the battery production in Europe and the USA.
- The electricity used for EV is based on the country’s specific annual average grid electricity generation mix, including imports and exports.
- The electricity generation mix for each country reflects generation in 2014 to 2018.
- The particulate emissions (< 10 µm) are only given in their total mass and not differentiated according to their size/toxicity.

Due to these assumptions, the variation in the estimated impacts of electric vehicles between countries is due to variation in:

- emissions from national electricity production,
- average electricity consumption (kWh/km) by EV fleet in real world driving cycles,
- average fuel consumption of substituted conventional ICEs,
- emissions standards for vehicles and stationary power generation and
- travel behaviour (annual distance travelled by each vehicle technology).

### 2.7.3 Results

In [Figure 12](#), an example (Austria) of the “Country Factsheets on Estimated Environmental Impacts of Current EV-Fleet” is shown, which contains all relevant data and results for the LCA for one country. It shows the development of the EV fleet, the electricity generation and the environmental effects of the electricity generation and of the EV fleet.

The range of environmental effects of the current national electricity supply (at the charging point) is shown for the IEA HEV countries in [Figure 13](#) and Non IEA HEV countries in [Figure 14](#) (example GHG emissions in g CO<sub>2</sub>-eq per kWh at the charging point). The GHG emissions are close to 1,000 g CO<sub>2</sub>-eq/kWh in countries with a high share of power plants using fossil fuels (e.g. SA, ID) and lower than 20 g CO<sub>2</sub>-eq/kWh in countries with a high share of renewable and/or nuclear electricity generation (e.g. SE, NO). It is expected that the share of renewable electricity will further increase globally, while the amount of fossil based electricity will reduce. However, the scenario development of the global future electricity mix EV fleet under different conditions is not part of the activities of the IEA HEV Task 30.

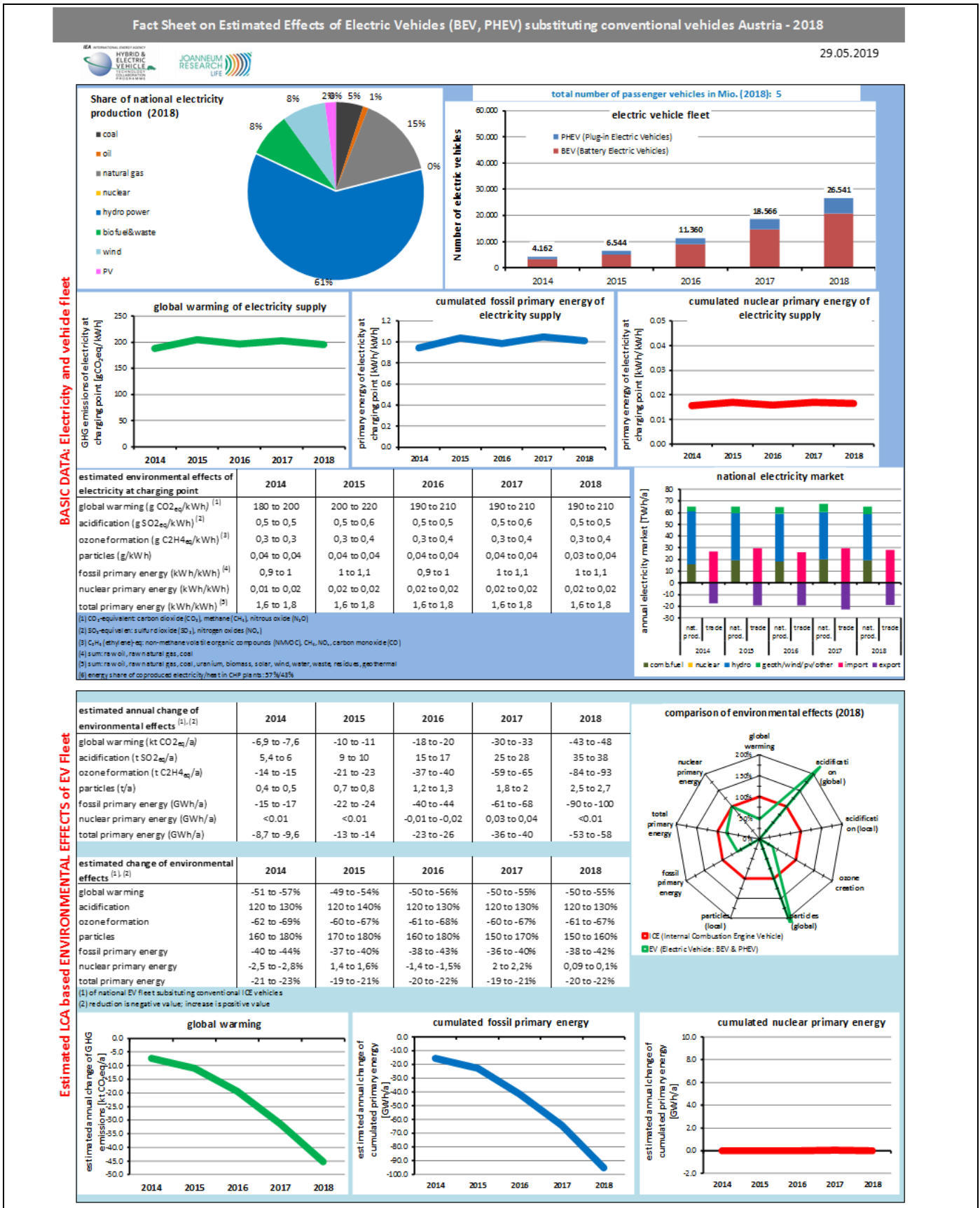

Figure 12: Country Factsheet on estimated environmental impacts of current EV-fleet – Example Austria

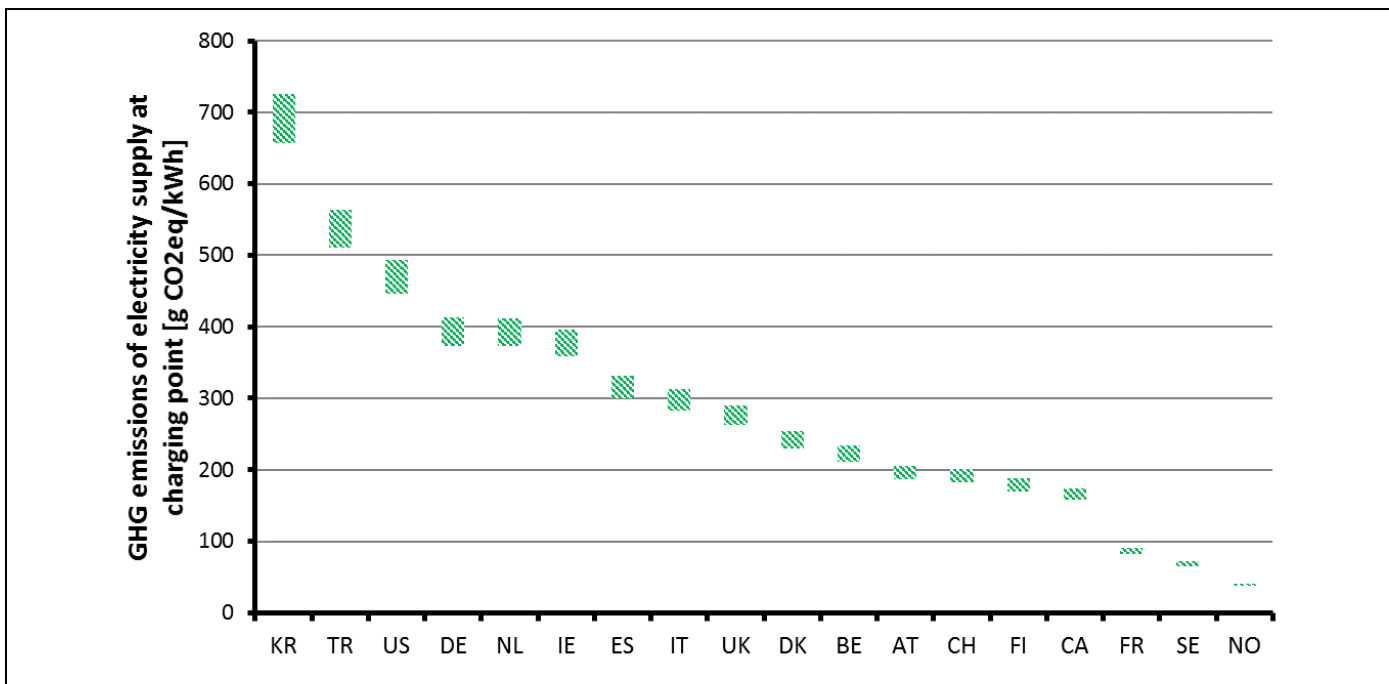

Figure 13: Estimated range of GHG emissions of electricity at charging point in IEA HEV countries in 2018

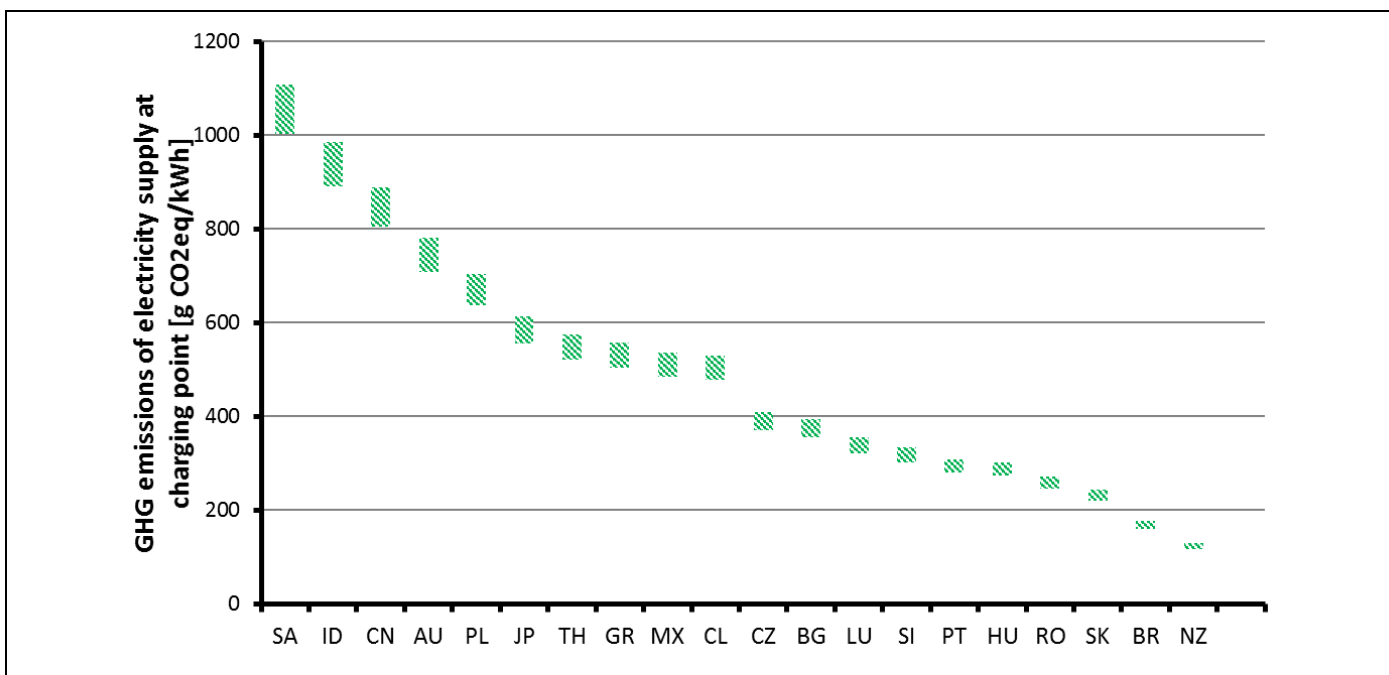

Figure 14: Estimated range of GHG emissions of electricity at charging point in Non IEA HEV countries in 2018

The estimated GHG change of EVs compared to ICE are shown in [Figure 15](#) for the IEA HEV countries and in [Figure 16](#) for the Non IEA HEV countries. In countries with a high share of renewable and/or nuclear electricity the GHG emissions reduction of the EVs is between 60 – 70%, whereas countries with

a high share of fossil generated electricity have a low GHG emission reduction. If the GHG emission of the electricity at the charging point is > 600 g CO<sub>2</sub>-eq per kWh electricity an increase of GHG emissions of the EVs compared to ICE is detected.

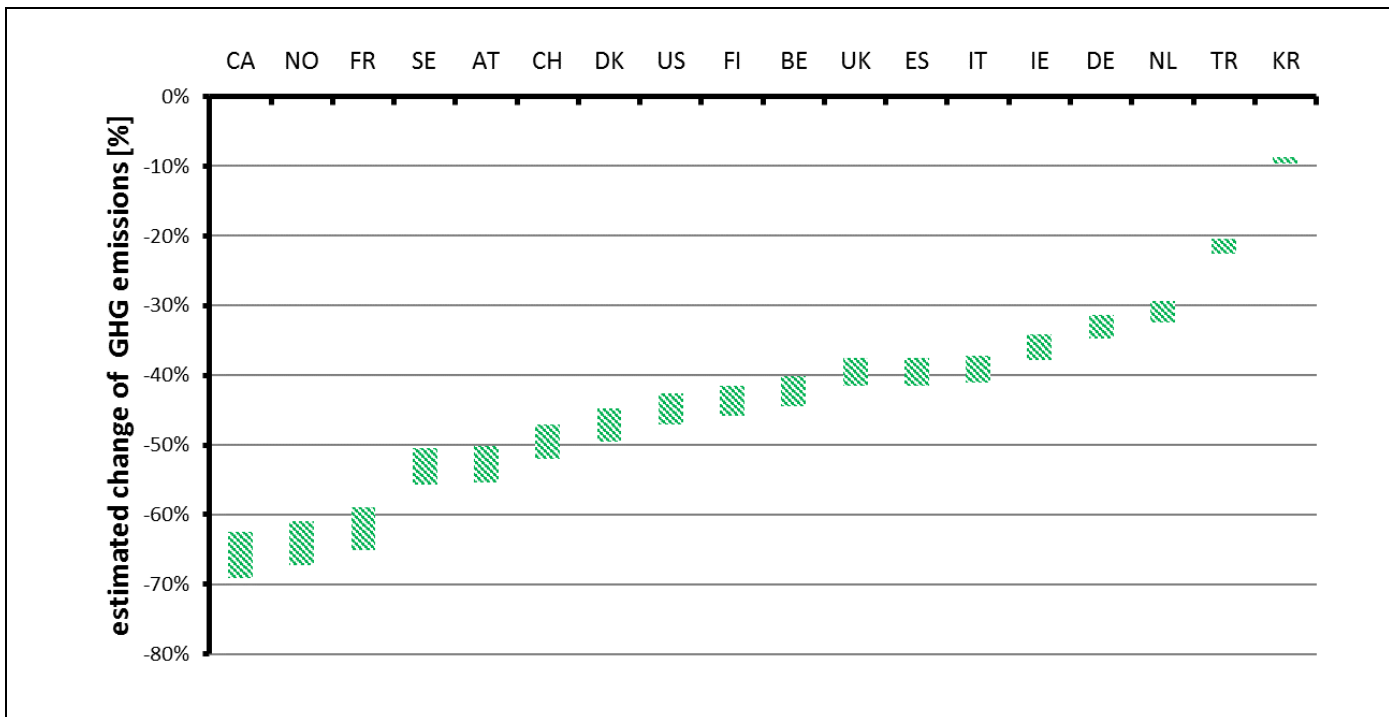

Figure 15: Estimated range of GHG emissions reduction of EVs substituting ICE vehicles in IEA HEV countries in 2018

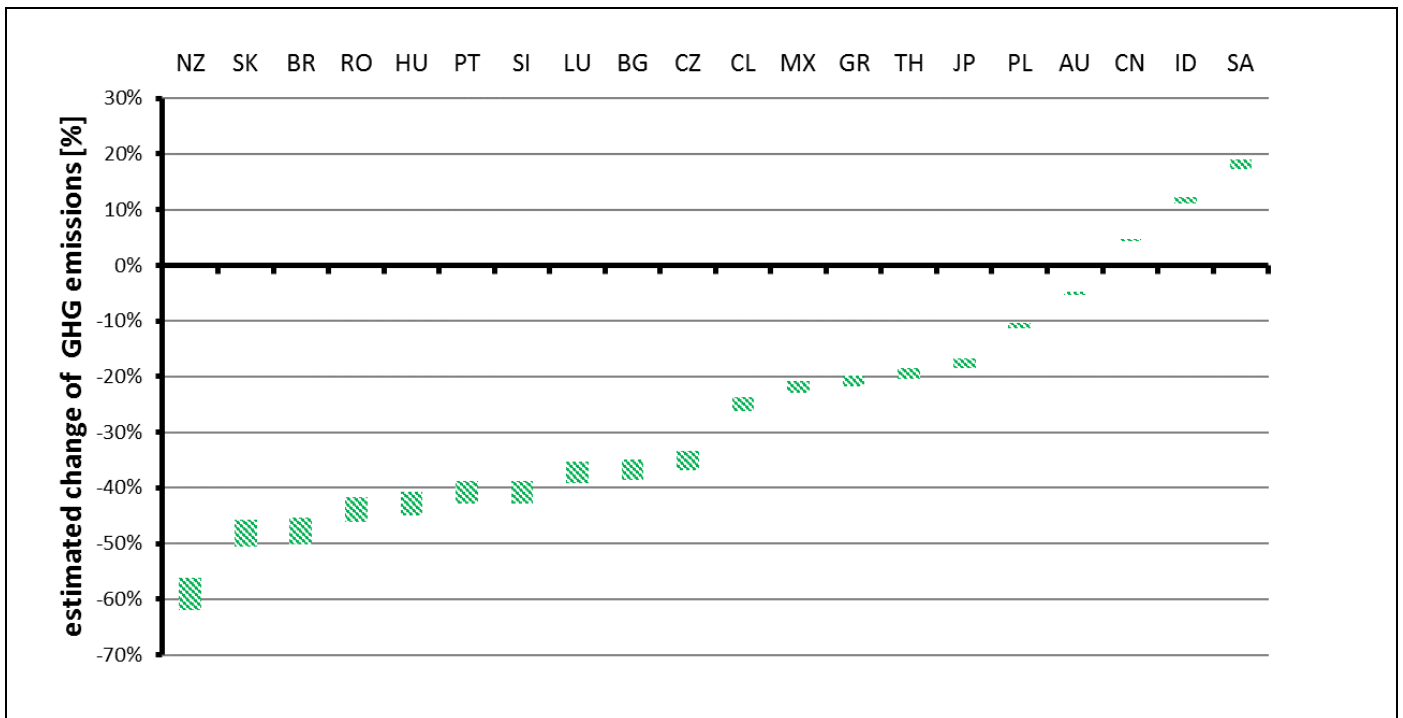

Figure 16: Estimated range of GHG emissions reduction of EVs substituting ICE vehicles in Non IEA HEV countries

Based on the country specific results the total global environmental effects in 2014 to 2018 of the globally increasing EV fleet are estimated. [Figure 17](#) shows the total reduction of GHG emissions with a range between 4.6 – 5.1 Mt CO<sub>2</sub>-eq in 2018, mainly resulting from the EVs fleet in IEA HEV countries, whereas the sum of the Non IEA HEV countries show nearly no effect in changing the GHG emissions. The estimated change of cumulative primary energy demand of the global EV fleet gives a reduction between 4,800 – 5,400 GWh/a, which is shown in [Figure 18](#). The IEA HEV countries substantially contribute to this reduction, where the Non IEA HEV countries even result in an increase of cumulated primary energy demand.

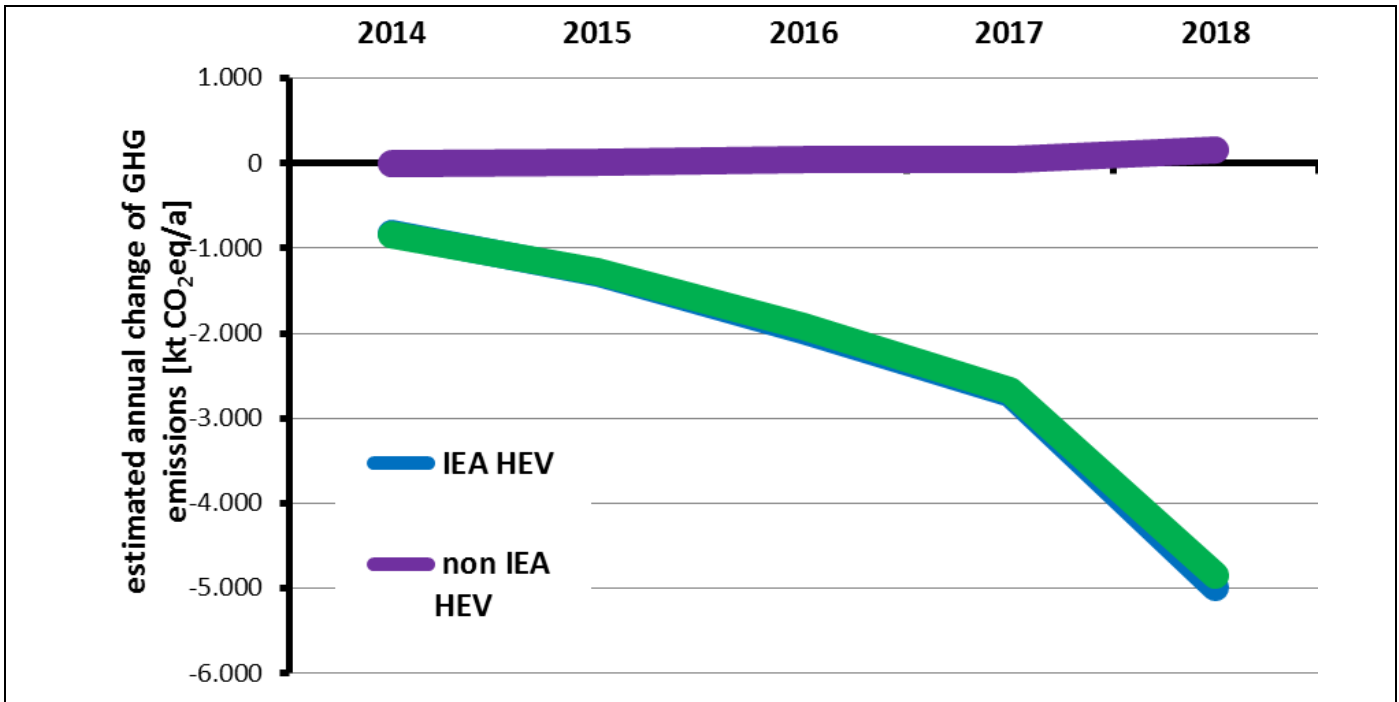

Figure 17: Estimated range of increasing GHG reduction of EVs substituting ICE vehicles globally (2014 – 2018)

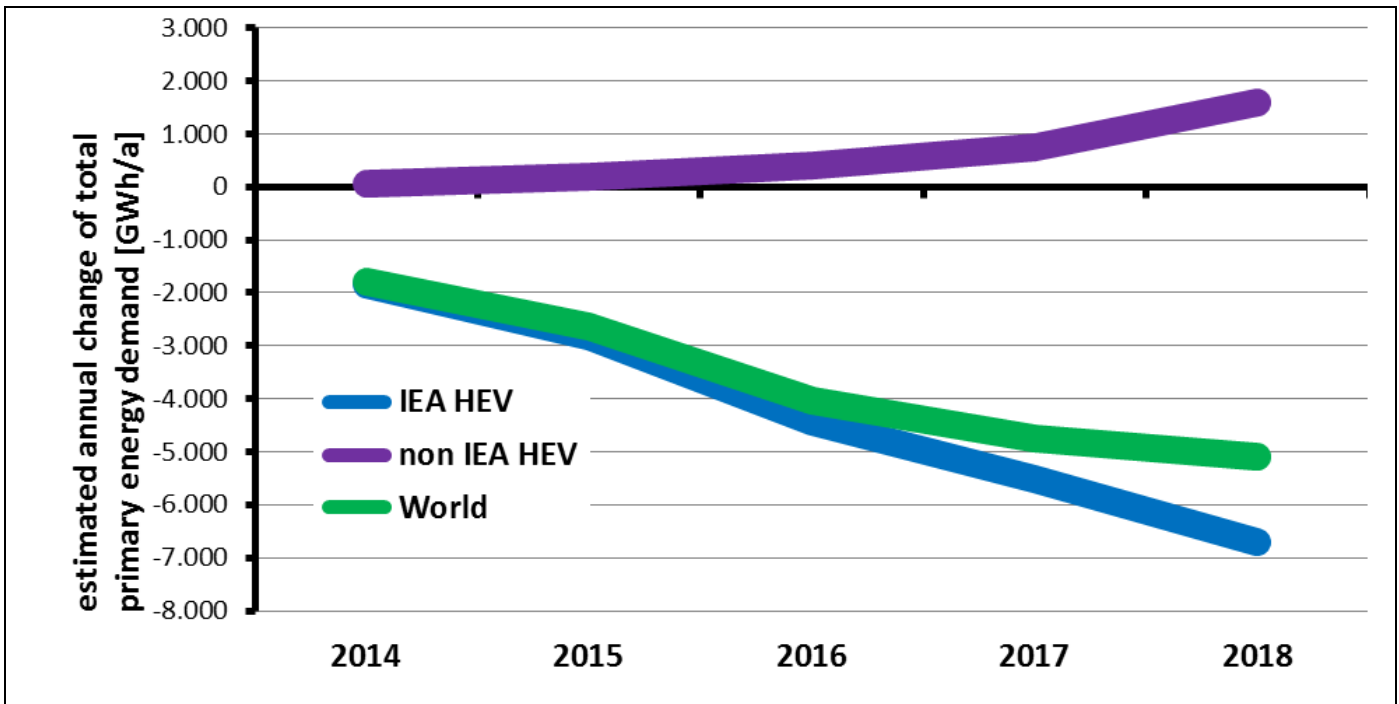

Figure 18: Estimated range of change in cumulative primary energy demand of EVs substituting ICE vehicles globally (2014 – 2018)

It is concluded that the share of electricity produced from fossil fuel has a substantial influence on the EV related emissions. A relatively large share of renewable or/and nuclear electricity contributes to substantial environmental benefits in the affected countries (e.g. NO, FR, AT), on the other side a



relatively large share of fossil electricity contributed to an increase of impacts in the relevant countries (e.g. PL, CN).

Summarizing the estimated environmental effects of the global fleet of BEVs and PHEVs substituting for diesel and gasoline ICE vehicles shows for 2018 the following (Table 5):

- GHG-reduction: 23% to 26%,
- fossil primary energy reduction 23% to 25%,
- renewable primary energy increase 57% to 63%,
- nuclear primary energy increase 800% to 900% and
- total primary energy reduction 7.8% to 8.7%.

Table 5: Estimated change of environmental effects of global EV fleet in 2018

Environmental effect		Change	
Emissions			
	GWP	- 4.6 to - 5.1 [Mt/a]	- 23 to - 26 %
	Acidification	+ 23 to + 26 [kt/a]	+ 370 to + 400 %
	Ozone formation	- 9.0 to -10 [kt/a]	- 31 to - 34 %
	Particles	+ 3.1 to + 3.5 [kt/a]	+ 870 to + 960 %
Cumulated primary energy			
	fossil	- 13 to - 14 [TWh/a]	- 23 to - 25 %
	nuclear	+ 4.7 to + 5.2 [TWh/a]	+ 800 to + 900 %
	renewable	+ 3.2 to + 3.5 [TWh/a]	+ 57 to + 63 %
	total	- 4.8 to - 5.4 [TWh/a]	- 7.8 to - 8.7 %

The variation in the emissions of national electricity production, the electricity consumption of EVs at charging point and the fuel consumption of the substituted conventional ICEs mainly determine the estimated range of environmental effects.

The analyses shows that the environmental benefits strongly depend on the national framework condition, i.e. national grid mix of electricity generation. A significant reduction of GHG emissions (up to 80%), compared to conventional ICE vehicles, is reached in some countries due to a high share of renewable and non-fossil based electricity generation. Additional renewable electricity with synchronized charging will maximize the environmental benefits of EVs and adequate loading strategies are essential for further reductions.

There is strong evidence from the current data of EV fleet deployed in various countries that using a relevant share of renewable electricity in electric vehicles play a substantial role in the future of sustainable transportation, especially with the expected increase in renewable electricity generation.

## 2.7.4 Conclusions

Concluding on the environmental assessment of the global EV fleet based on Life Cycle Assessment compared to the substituted conventional ICE vehicles leads to the following key issues:

- The environmental effects depend on the national framework condition, e.g. national grid electricity generation mix.
- The broad ranges of possible environmental effects is caused by the:
  - emissions of the national electricity production and distribution,
  - electricity consumption of EVs at charging point and
  - fuel consumption of substituted conventional ICE vehicles-
- The highest environmental benefits can be reached by using additional installed renewable electricity, which is synchronized with the charging of the EVs.
- The adequate loading strategies for EVs to integrate additional renewable electricity effectively will create further significant environmental benefits.

This assessment shows the strong evidence that electric vehicle can contribute substantially to a sustainable future of the transportation sector in various countries if renewable electricity is used.

## 2.7.5 References

1. Jungmeier G., Dunn J., Elgowainy A., Gaines L., Ehrenberger S., Özdemirc E. D., Althaus H. J., Widmer R. Life cycle assessment of electric vehicles – Key issues of Task 19 of the International Energy Agency (IEA) on Hybrid and Electric Vehicles (HEV), Conference Proceedings, TRA 2014 - 5th Conference Transport Solutions – From Research to Deployment, Paris, France, 14 – 17. April 2014
2. Jungmeier G., Dunn J., Elgowainy A., Ehrenberger S., Widmer R. Estimated Environmental Effects of the Worldwide Electric Vehicle Fleet – A Life Cycle Assessment in Task 19 of the International Energy Agency (IEA) on Hybrid and Electric Vehicles (HEV), Conference Proceedings, EEVC 2015 - European Battery, Hybrid and Fuel Cell Electric Vehicle Congress, Brussels, Belgium, 2 – 4. December 2015
3. G. Jungmeier et al. Estimation of Environmental Effects of the Worldwide Electric Vehicle Fleet in 2014 - A Life Cycle Assessment in Task 19 of the International Energy Agency (IEA) on Hybrid and Electric Vehicles (HEV), Proceedings of EVS 28, Korea, May 3-6, 2015
4. G. Jungmeier et al. Life-cycle Based Environmental Effects of 1.3 Mio. Electric Vehicles on the Road in 35 Countries – Facts & Figures from the IEA Technology Collaboration Program on Hybrid & Electric Vehicles, Proceedings of EVS 30, Germany, October 9 – 11, 2017
5. Assessment of Environmental Effects of Electric Vehicles. Available online: <http://www.ieahev.org/tasks/task-30-assessment-of-environmental-effects-of-electric-vehicles/>
6. G. Jungmeier, S. Seebauer, L. Canella, A. A. Elgowainy, S. Ehrenberger, G. Benveniste-Perez, P-O. Roye, L. Ocktaek, T. Yuksel, (2019) Time and Rebound Effects in the LCA of Electric Vehicles, Proceeding of IEWT 2019, Vienna, February 13 – 15, 2019
7. IEA 2019: Global EV Outlook - Scaling-up the transition to electric mobility, <https://webstore.iea.org/global-ev-outlook-2019>

8. IEA-HEV Annual Reports 2014 – 2019, <http://www.ieahev.org/news/annual-reports/>, 2019

## 2.8 Issues on Dynamic LCA of Vehicle Fleets

### 2.8.1 Introduction

Issues on dynamic LCA, e.g. annual environmental effects, become relevant for the rapidly increasing of EV-fleets combined with an additional generation of renewable electricity. For this, the Task identified the following relevant methodological aspects:

- 1) timing of environmental effects in the three lifecycle phases,
- 2) timing of environmental effects of increasing supply of renewable electricity,
- 3) timing of environmental effects of EVs using increasing supply of renewable electricity and
- 4) substitution effects and timing of environmental effects of EVs substituting ICE vehicles.

### 2.8.2 Methodological Aspects

The possible environmental effects of a system occur at different times during their lifetime. In LCA, the environmental effects are analysed for the three phases separately – production (for vehicles) or construction (for power plants), operation and end of life – over the whole lifetime of a system. Then the cumulated environmental effects over the lifetime are allocated to the service provided by the system during the operation phase, which is the functional unit in LCA, e.g. per kilometre driven for vehicles and kWh generated for power plants. Therefore, the functional unit gives the average environmental effects over lifetime by allocating the environmental effects for production and end of life over the lifetime to the service provided independent of the time when they occur.

Another approach considered in the Task is to reflect and keep the time depending course of the environmental effects in the life cycle and compare the absolute cumulated environmental effects in a dynamic LCA.

In Figure 19, the possible courses of the cumulated environmental effects of three systems in their lifetime are shown for the three phases – production, operation and end of life. All the three systems – A, B and C - have the same lifetime and provide the same service but the courses of the environmental effects are quite different. The system A has low environmental effects in the production/construction phase but high effects during the operation/use phase and again low effects in the end of life phase. While system B has very high effects in the production phase, very low further effects in the operation phase and declining environmental effects in the end of life phase due to the recycling of materials and a credit given for the supply of secondary materials for substituting primary material. The system C has lower effects in production/construction phase than system B and no further effects during the operation phase, but significantly declining environmental effects in the end of life phase, which is due to the reuse of certain parts, facilities or materials for other further purposes.

Considering the total cumulated environmental effects, system C has the lowest and system A the highest effects in their lifetime. However, additionally it can be analysed at which time in the lifecycle the

system C has lower cumulated environmental effects compared to the other systems. At time  $t_1$  system C has lower cumulated environmental effects than system B; at time  $t_2$  system B has equal cumulated effects than system A.

This timing of the environmental effects becomes more relevant in future, when new innovative systems substitute conventional systems to reduce the overall environmental effects. However, it might take some time until the real reduction of environmental effects takes place by the new innovative system. This aspect becomes more and more relevant in the context e.g. of the global necessary reduction of GHG emissions with increasing energy efficiency and renewable energy. Therefore, in dynamic LCA the course of the cumulated environmental effects have to be considered and addressed more adequately.

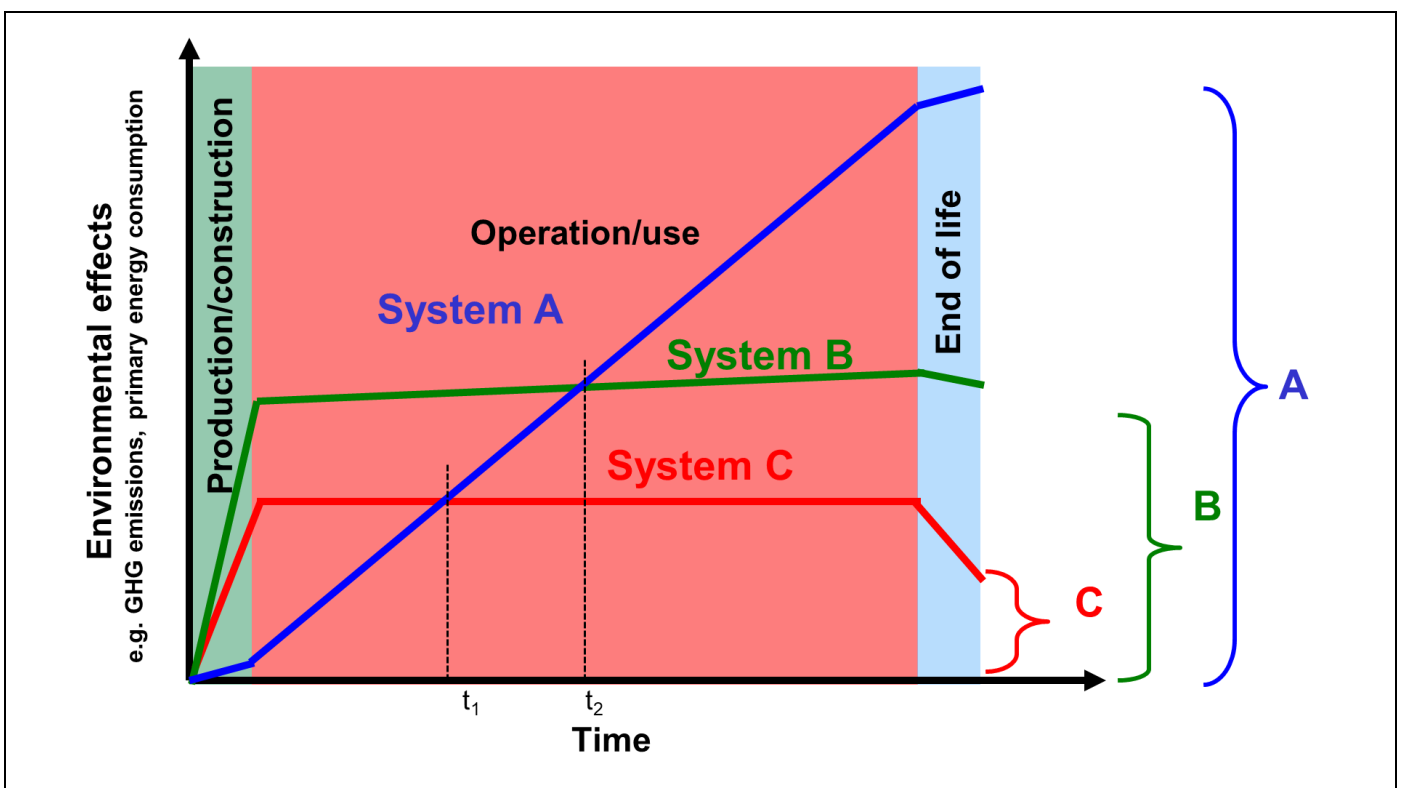

Figure 19: Timing of cumulated environmental effects of three systems with the same lifetime

In [Figure 20](#), the timing of environmental effects of a BEV using renewable electricity substituting an ICE vehicle is shown. In total over the lifetime the BEV has lower environmental effects, e.g. GHG emissions than the ICE. Due to the higher environmental effects from production of the BEV, the environmental effects are higher in the beginning, but after about 3 years the environmental benefits of substituting ICE vehicles starts. An additional effect is that due to the rebound effect (further details see Task 30 working document) not each electric driven kilometre might substitute a fossil fuel driven kilometre. Therefore, the substitution rate might be lower than 100%. In the example below, the timing of environmental effects is shown for a substitution rate of 80% and 100%. Additionally, if the timing effects are analysed for a rapid annual increase of BEV the annual environmental effect might still be higher than the substituted ICE

vehicles. So depending on the annual growing size of the BEV fleet it might take some time until the overall annual environmental effects decline by substitution of ICE vehicles.

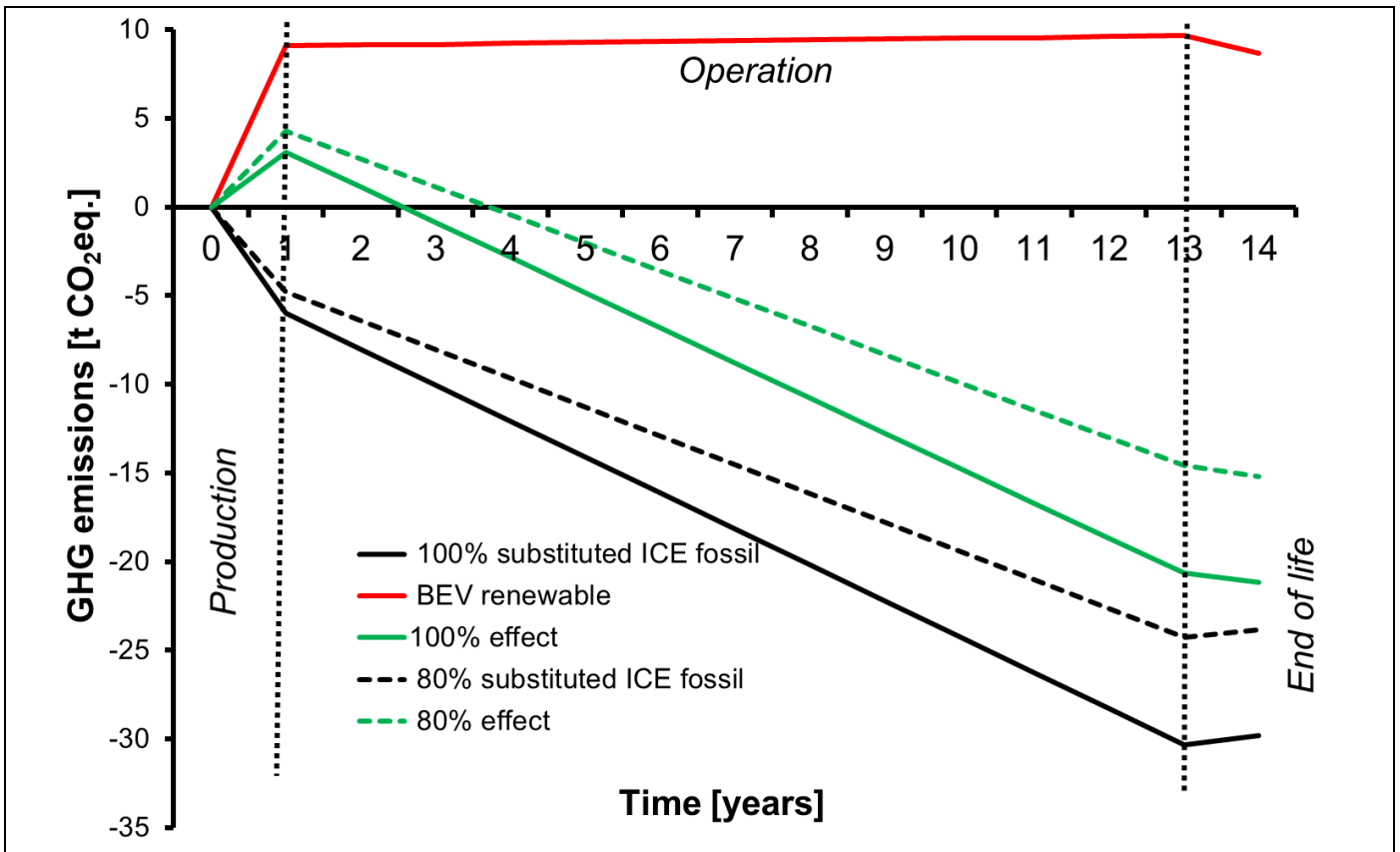

Figure 20: Timing of environmental effects of a BEV using renewable electricity substituting an ICE vehicle

### 2.8.3 LCA of Supplying Additional Renewable Electricity – Example Austria

It is relevant to analyse and assess the environmental effects of the increasing production of renewable electricity generation and its use, e.g. in BEV. The environmental effects, e.g. GHG emissions, of electricity from hydro, wind and solar power plants mainly occur in the construction and the end of life phases. In most countries, there are huge investments in new facilities to generate additional renewable electricity. Related to these investments significant environmental effects are taking place with these investments, but the substitution of conventional electricity generation will lead to a reduction of environmental effects in the coming years.

To illustrate the timing of the environmental effects in a dynamic LCA perspective the following example of Austria of increasing renewable electricity generation is described.

The additional renewable electricity generation in Austria increased between 0.2 up to 2.2 TWh per year from 2005 up to 2020. In Figure 21, the total renewable electricity generation in Austria is shown from 2005 to 2020. Already in 2004 about 40 TWh renewable electricity was generated mainly in hydro power plants. Over the years, the generation from renewable electricity increased from 41 TWh in 2005 up to

57 TWh in 2020 significantly. The share of renewable electricity in the Austrian grid mix (incl. imports) increased from about 60% in 2005 up to 75% in 2020.

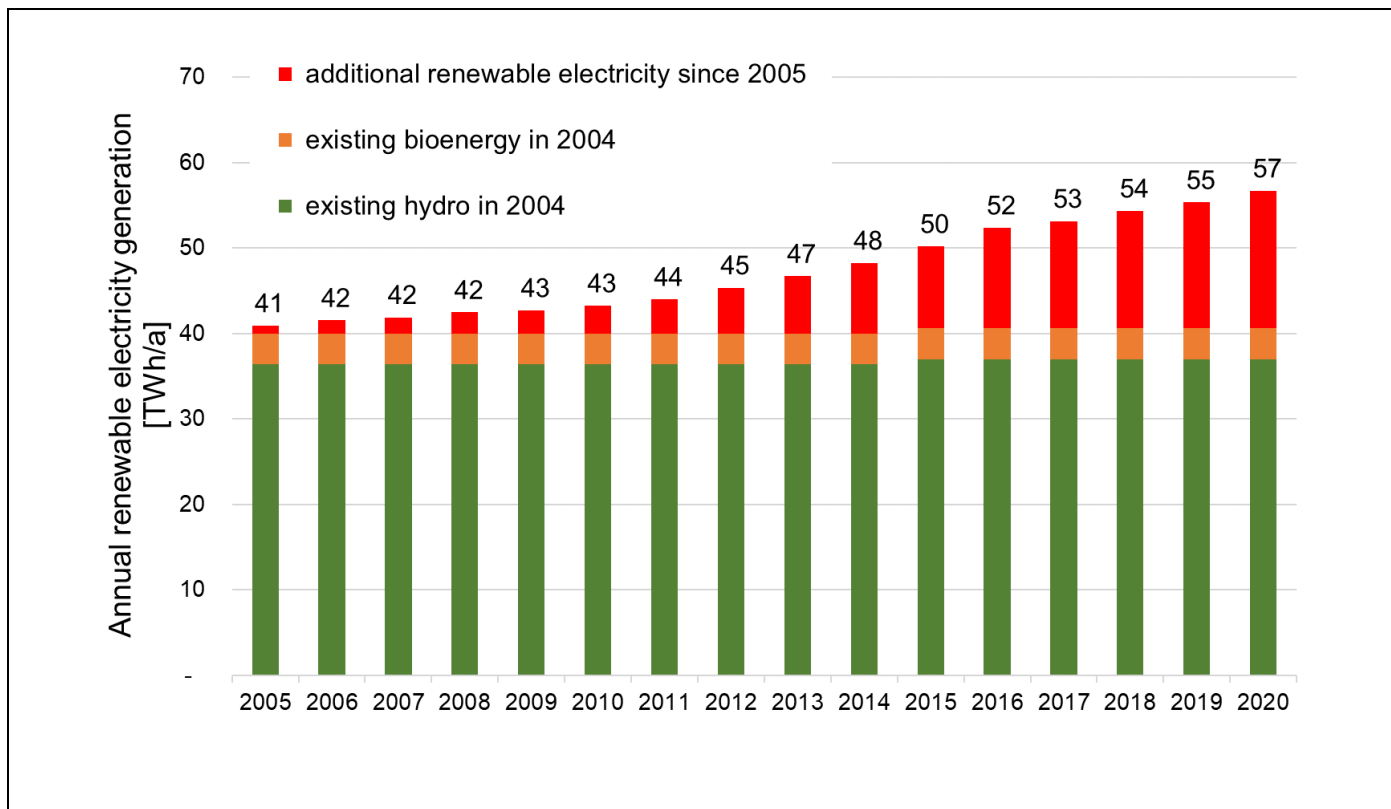

Figure 21: Renewable electricity generation in Austria (references are given in working document)

The annual GHG emissions due to the installation of new renewable electricity generation plants in Austria were between 100,000 up to 800,000 t CO<sub>2</sub>-eq per from 2005 to 2020, depending on the annual installed generation capacity and the type of renewable energy. E.g. the installation of a PV power plant to generate 1 GWh annually with about 1,400 to 1,600 t CO<sub>2</sub>-eq has significantly higher GHG emissions than a hydro or wind power plant with about 250 – 600 t CO<sub>2</sub>-eq per 1 GWh annually.

The combination of the annual GHG emissions and the additional electricity generation gives the specific GHG emissions of renewable electricity generation in Austria (Figure 22), on one hand the GHG emissions of the additionally installed renewable electricity generation and on the other hand the total renewable electricity mix in Austria. Due to the chosen dynamic LCA approach here, the GHG emissions of the construction of renewable electricity generation plants before 2005 are not considered in the years from 2005 onwards, only the relatively low GHG emissions of operating the plants for maintenance and the fuel supply for bioenergy are included. So the GHG emissions of renewable electricity generation in Austria in existing (before 2005) and newly installed power plants (since 2005) are in the range between 8 to 33 g CO<sub>2</sub>-eq/kWh, whereas the GHG emissions of the additionally installed renewable electricity generation is between 31 and 250 CO<sub>2</sub>-eq/kWh between 2005 and 2020.

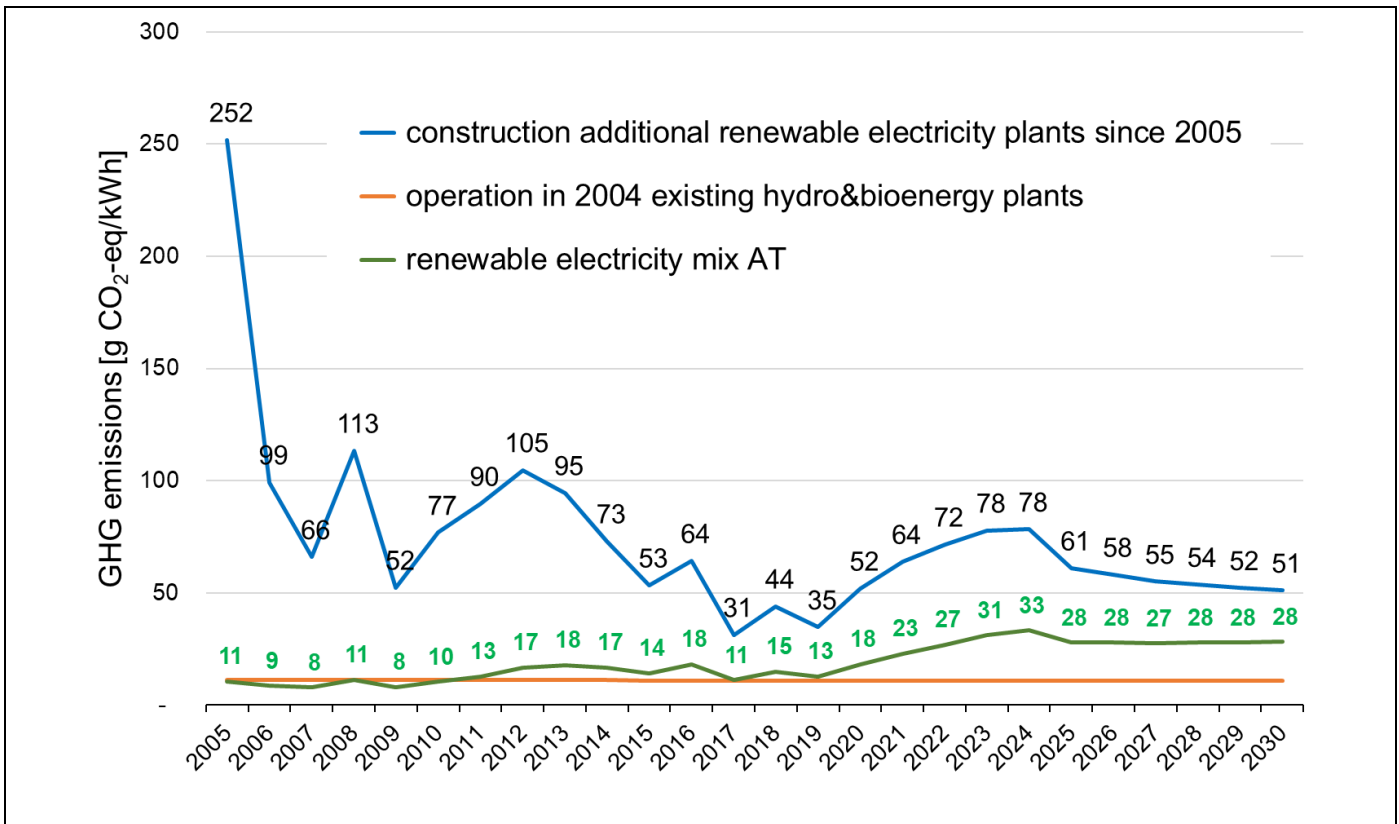

Figure 22: GHG emissions of renewable electricity generation in Austria

### 2.8.4 GHG Emissions of BEV Introduction in Austria

The environmental assessment of the global EV fleet based on LCA compared to the substituted conventional ICE vehicles leads to the following key issues:

- The environmental effects depend on the national framework condition, e.g. national grid electricity generation mix.
- The broad range of possible environmental effects is caused by the:
  - emissions of the national electricity production and distribution,
  - electricity consumption of EVs at charging point, and
  - fuel consumption of substituted conventional ICE vehicles.
- The highest environmental benefits can be reached by using additional installed renewable electricity, which is synchronized with the charging of the EVs.
- The adequate loading strategies for EVs to integrate additional renewable electricity effectively will create further significant environmental benefits.

Now this approach was further developed by taking the dynamic effects of introduction of BEV fleets and increasing supply of renewable electricity.



The introduction of BEV in Austria started in 2010. Additionally, also PHEV were introduced, which are not considered here. The annually registered BEV increased significantly and reached nearly 16,000 new BEVs in 2020. The BEV fleet increased up to about 46,000 BEVs in 2020. The rapid increase of the BEV fleet in Austria was stimulated by public funding of up to € 6,000 for the investment and the charging stations. If the supply of renewable electricity for the operation of the BEV is guaranteed by a corresponding electricity purchase contract.

Assuming an electricity demand of about 0.22 kWh/km (incl. heating, cooling and auxiliaries) and 10% grid and charging losses the additional renewable electricity demand for the operation of the BEV fleet increased from 0.3 GWh in 2010 up to 142 GWh in 2020. Considering the increased renewable electricity generation since 2010 in Austria the demand to operate the BEV fleet is in a range of 0.1 to 1.1% of the additional renewable electricity generated since 2010. Concluding, also in this system perspective it is evident that the Austrian BEV fleet is operated on renewable electricity, while the increasing demand for electricity is met with increasing supply of renewable electricity.

Considering the course of the annual GHG emissions of the renewable electricity generation in Austria, the GHG emissions of the operations of the BEV fleet in Austria are calculated using the GHG emission (2010 – 2020) between 10 to 18 g CO<sub>2</sub>-eq/kWh. The GHG emissions of BEV fleet operation using the renewable electricity mix in Austria are in average between 2.5 to 4.5 g CO<sub>2</sub>-eq/km without considering maintenance and spare parts. Therefore, in average between 2010 and 2020 the GHG emissions of a BEV operating in Austria are about 3.6 g CO<sub>2</sub>-eq/km.

In addition, the GHG emissions from the production of the new registered BEV are calculated in an LCA perspective. The average GHG emissions of the global battery production has decreased from about 100 kg CO<sub>2</sub>-eq per kWh battery capacity in 2010 to about 70 kg CO<sub>2</sub>-eq/kWh. At the same time the battery capacity of a new BEV in Austria increase from about 30 kWh in 2010 to about 65 kWh in 2020 in average, due to the lower battery costs and the demand for higher driving ranges. Therefore, the production of a new BEV between 2010 and 2020 causes GHG emissions between 8.5 up to 10.5 t CO<sub>2</sub>-eq. In comparison, the production of a conventional new ICE vehicle causes about 6 t CO<sub>2</sub>-eq. However, the operation of a conventional substituted ICE vehicle has GHG emissions of about 145 g CO<sub>2</sub>-eq/km with an average fuel consumption of about 0.52 kWh/km.

The GHG emissions of the BEV introduction since 2010 in Austria are calculated by considering the GHG emissions of the production from the annually new registered BEV and the operation of the BEV fleet by taking the substituted conventional ICE vehicles into account.

In [Figure 23](#), the change of GHG emissions of the BEV fleet substituting an ICE fleet in Austria are shown. In 2020, the GHG emissions of the production of the newly registered 16,000 BEV are about 167,000 t CO<sub>2</sub>-eq and the GHG emissions of the BEV fleet operation of about 45,000 vehicles with renewable electricity are about 3,000 t CO<sub>2</sub>-eq.

Assuming each BEV substitutes for an ICE, about 16,000 newly registered conventional ICE vehicle were substituted in 2020 avoiding GHG emissions from their production of about 96,000 t CO<sub>2</sub>-eq and avoiding GHG emissions of about 94,000 t CO<sub>2</sub>-eq in the ICE fleet operation of about 45,000 conventional ICE vehicles. Therefore, in 2020 the BEV fleet in Austria emitted about 170,000 t CO<sub>2</sub>-eq



and avoided about 190,000 t CO<sub>2</sub>-eq from substituting conventional ICE vehicles, which results in an overall GHG saving in 2020 of about 20,000 t CO<sub>2</sub>-eq.

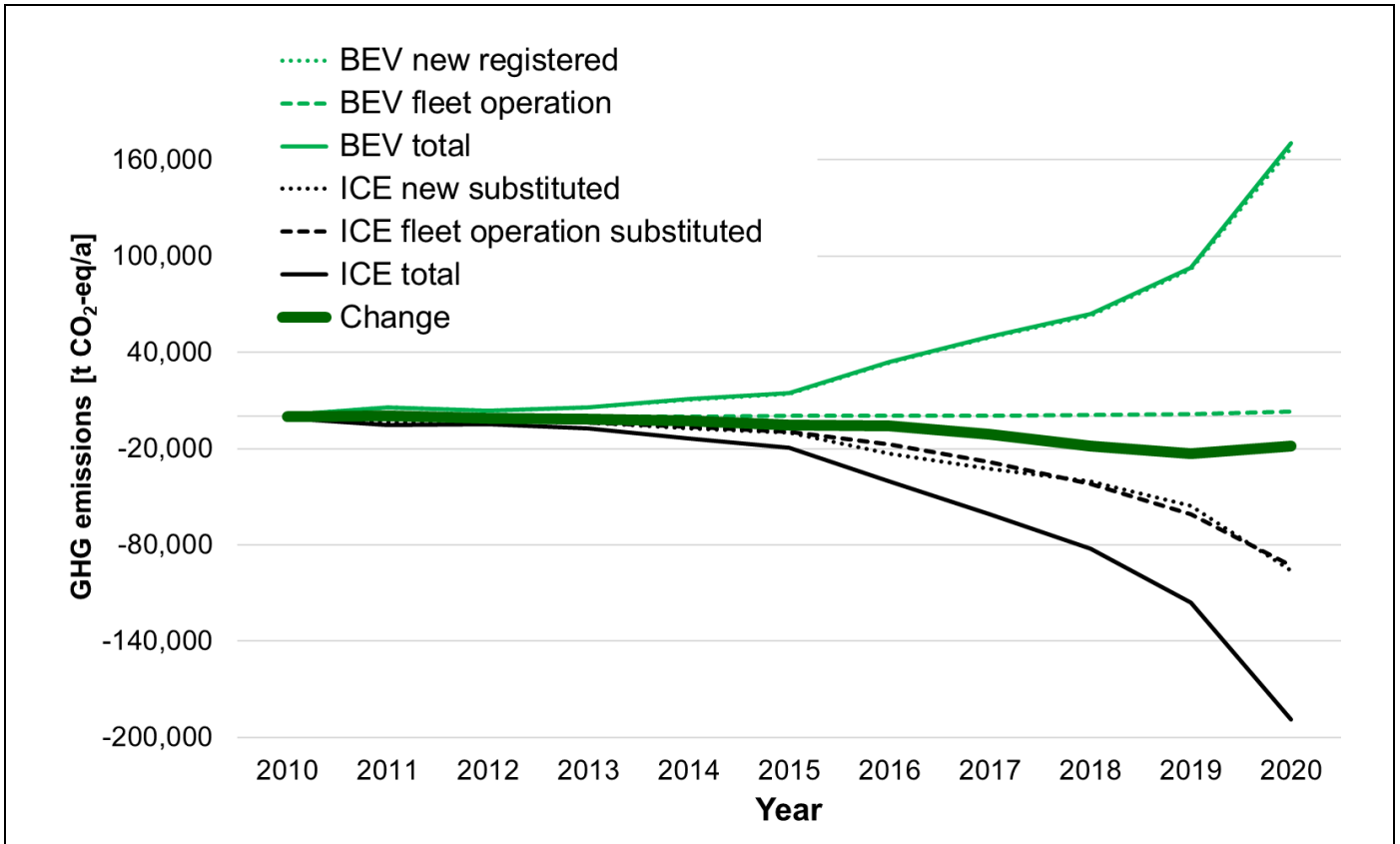

Figure 23: Change of GHG emissions of BEV fleet substituting ICE fleets in Austria

### 2.8.5 Scenarios for a Climate Neutral Passenger Vehicle Fleet in Austria 2040/2050

Based on the dynamic approach two scenarios for the “climate neutral” passenger vehicle fleet in Austria up to 2050 „BEV“ and „e-Fuel“ were developed.

The main characteristics of these two scenarios are:

- GHG reduction goals:
  - 2030: Austria about 55% reduction (based on 1990),
  - 2040: Austria „climate neutral“ transportation sector,
  - 2050: EU and USA climate neutral,
  - 2060: Rest of the world climate neutral,
- Fleet modelling with NEMO (Network Emission Model) used for OLI (Österreichische Luftschadstoff-Inventur):
  - different shares of new registrations since 2021: BEV and ICE/PHEV,
  - only domestic passenger vehicles (without „tank tourism“),

- vehicle fleet: remains constant,
- total annual kilometres: constant since 2020,
- renewable electricity for BEV & e-Fuel generated in new power plants in Austria/abroad integrated in existing renewable electricity mix,
- CO<sub>2</sub>-sources for e-Fuels:
  - 50 – 100 kt/a from biomass (e.g. fermentation, combustion)
  - 100 kt/a from air,
- amount of biofuels for passenger vehicles remain constant since 2020 (about 250 kt).

This modelling was done in cooperation of:

- JOANNEUM RESEARCH (LCA & modelling),
- Graz University of Technology (vehicle fleet),
- IEA HEV Task 30 (methodology).

In [Figure 24](#), the possible development of passenger vehicle fleet for climate neutrality 2050 is shown. In the BEV scenario, the vehicle fleet is renewed faster as nearly all newly registered vehicles have to be electric vehicles to reach the goal for 2030.

In [Figure 25](#), the passenger vehicle energy consumption is shown. In the BEV-Scenario, the energy consumption is significantly less than in the e-Fuel-Scenario, as the electric vehicles are more efficient than the ICE vehicles using e-fuels. The peak of e-fuel demand is in 2030 to reach a 55% GHG reduction, after 2030 the number of ICE vehicles further decreases so less e-fuel is needed. Nevertheless, in both scenarios a significant increase of generating additional renewable electricity is necessary.

In [Figure 26](#), the LCA based GHG-emissions of passenger vehicle fleet for climate neutrality 2050 are shown. In 2040, the GHG emission from vehicle operation are nearly zero, just some CH<sub>4</sub>- and N<sub>2</sub>O-emissions from the vehicle tail pipe remain. In 2050, due to the climate global neutrality the total GHG emissions are close to zero, a small amount still remains, as China and India claim to reach climate neutrality in 2060. The GHG emissions from vehicle end of life and vehicle export are negative, as “credits” are given for these effects.

In [Figure 27](#), the LCA based total primary energy demand of passenger vehicle fleet for climate neutrality 2050 is shown. It becomes evident that the e-Fuel-Scenario needs much more primary energy than the BEV-Scenario as the energy conversion from renewable primary energy to transportation service is much lower with e-fuels. To cover the peak amount of e-fuels in 2030 a very strong increase of additional renewable power plants is necessary in a very short period of time, and the construction of these new power plants is the reason for the peak of primary energy in 2030.

In [Figure 28](#), the cumulated results for 2020 – 2050 for the GHG emissions and the primary energy demand for both scenarios are shown. The cumulated GHG emissions and primary energy demand is lower in the BEV-Scenario, except the production of more BEV has higher GHG emissions. Considering energy efficiency, it becomes evident that the BEV-Scenario needs significantly less cumulated renewable primary energy than the e-Fuel-Scenario.

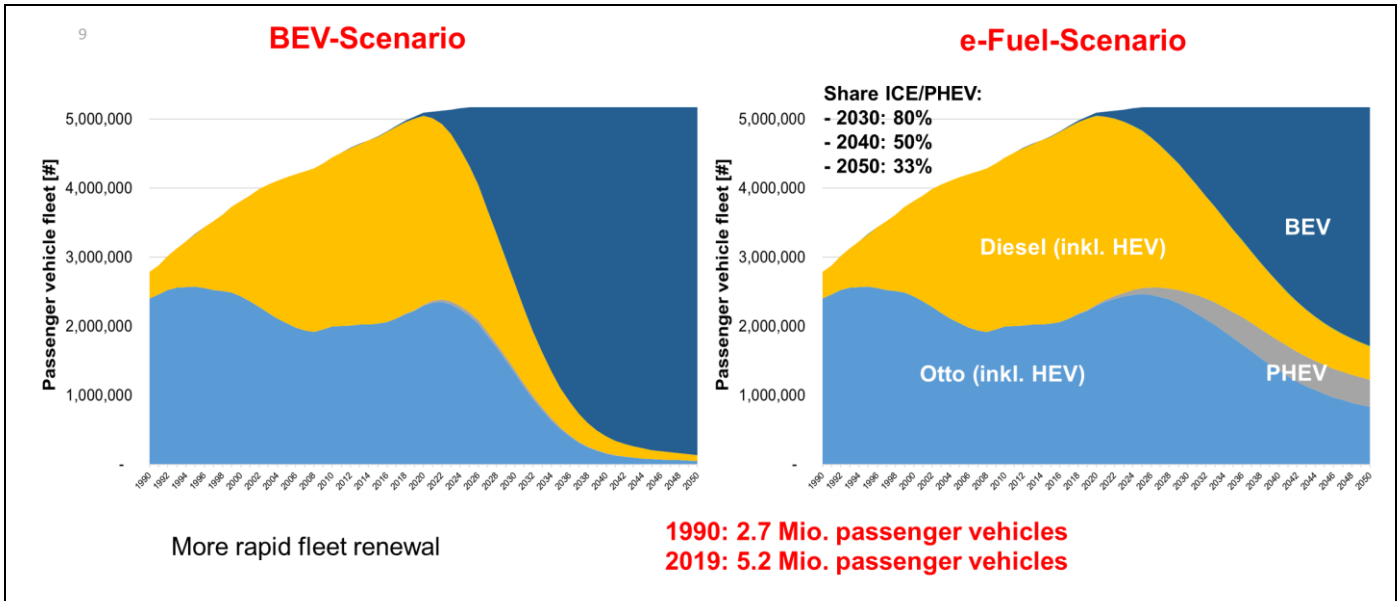

Figure 24: Development of passenger vehicle fleet for climate neutrality 2050

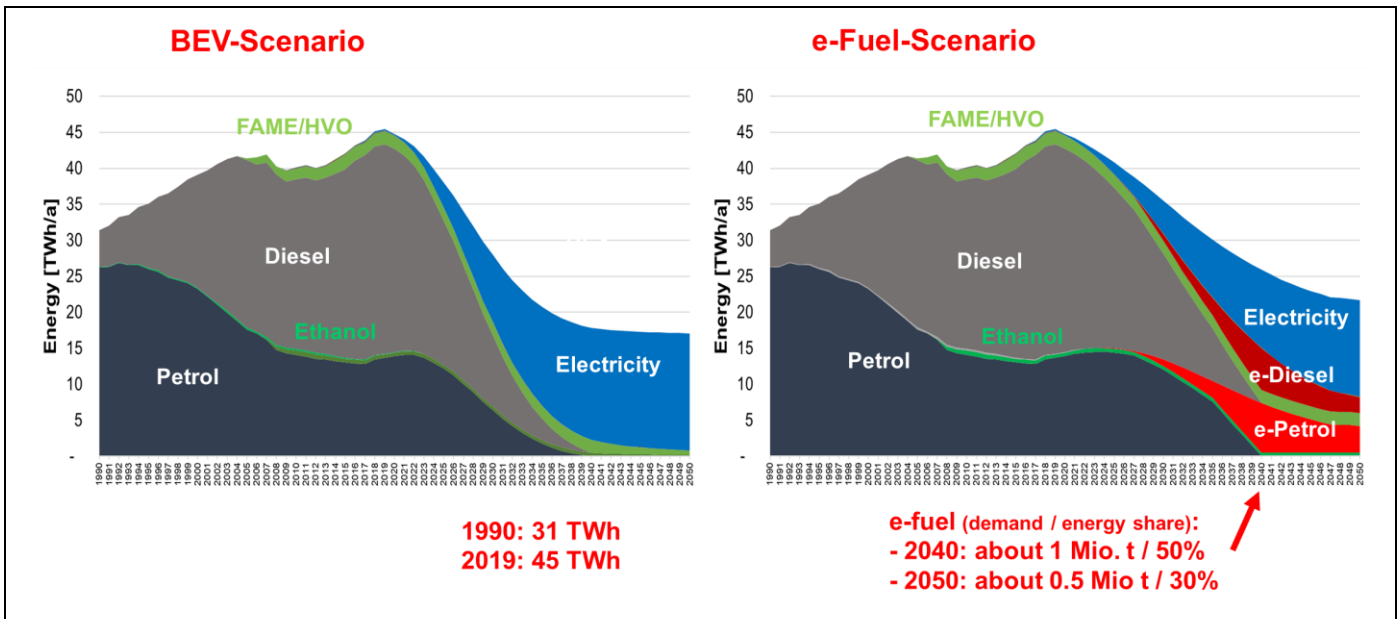

Figure 25: Passenger vehicle energy consumption

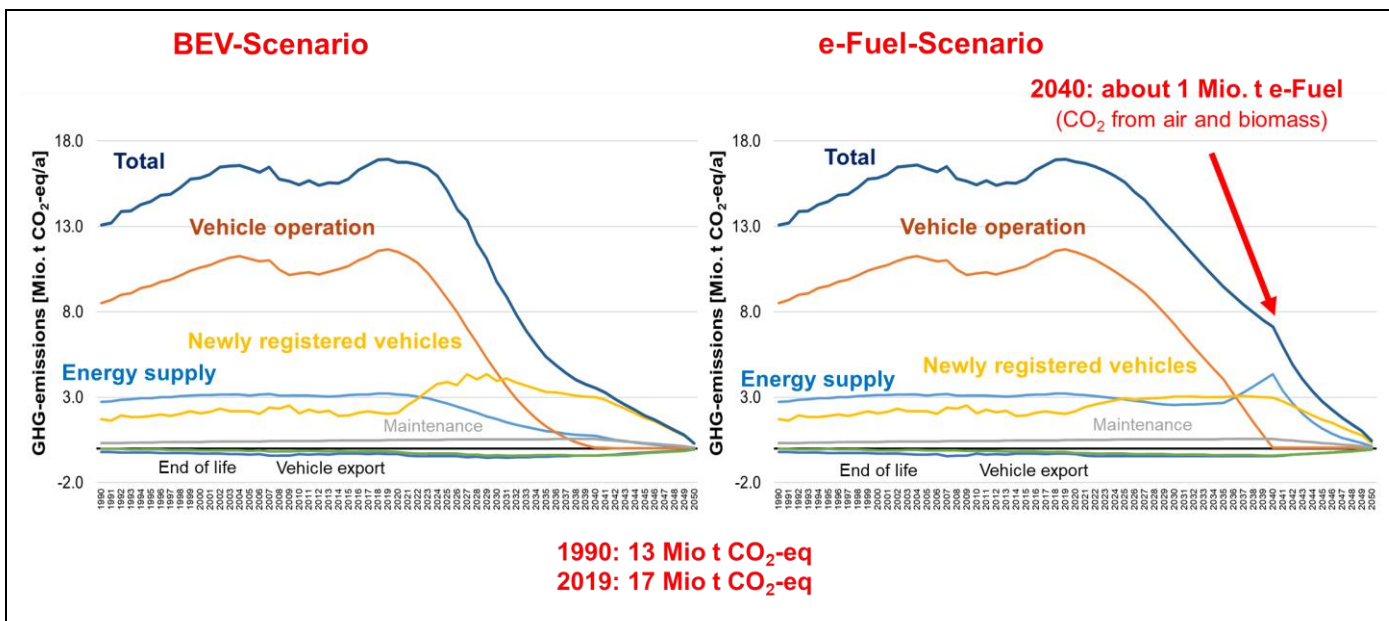

Figure 26: LCA based GHG-emissions of passenger vehicle fleet for climate neutrality 2050

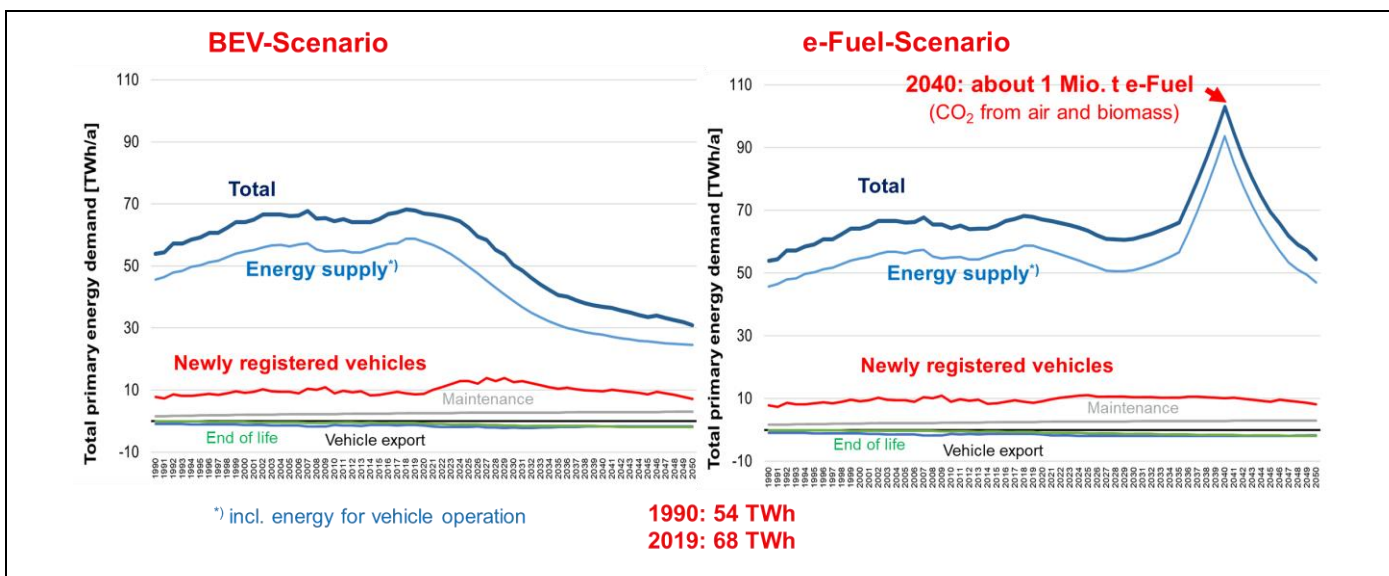

Figure 27: LCA based total primary energy demand of passenger vehicle fleet for climate neutrality 2050

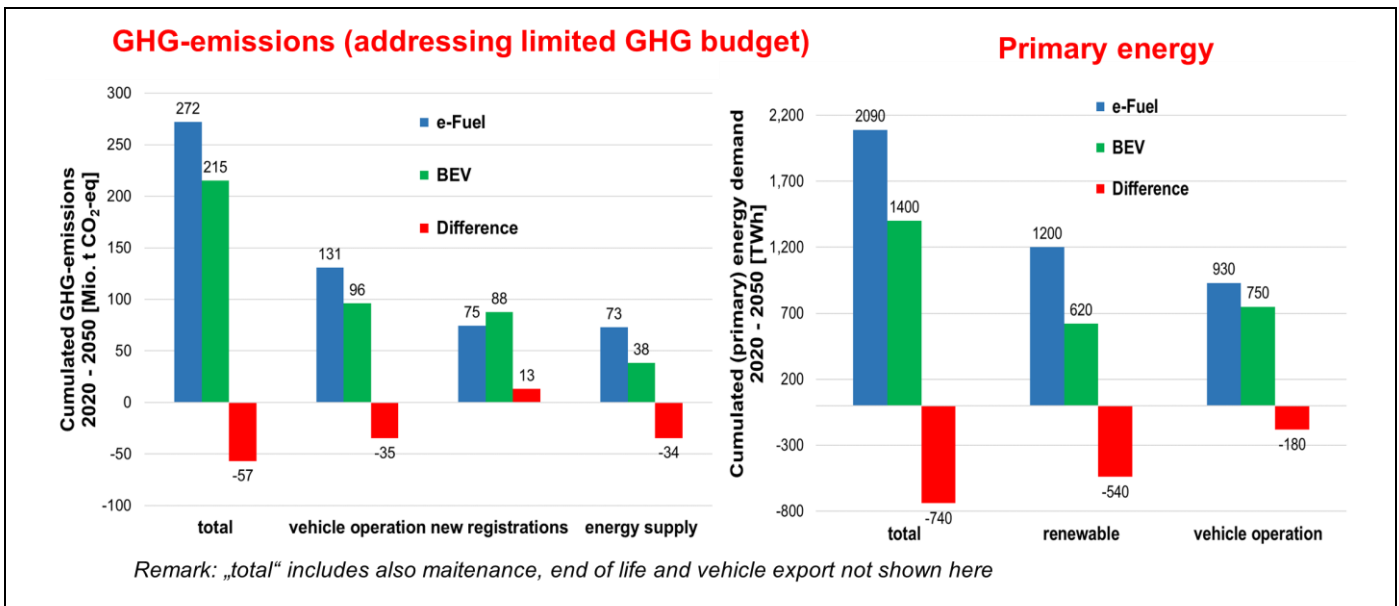

Figure 28: Cumulated results 2020 – 2050: BEV and e-Fuel-Scenario

The conclusions on dynamic LCA are:

- Timing of environmental effects in LCA of EVs production – operation - end of life phases becomes relevant in the transition time of:
  - strong BEV introduction in combination with a
  - strong increase of additional renewable electricity generation and
  - improvement of battery production technologies.
- Within the framework of LCA a methodology is developed and applied to the annual environmental effects of an increasing BEV fleet and substitution of ICE vehicles by considering the annual environmental effects of:
  - new vehicle production,
  - supply of renewable electricity from existing and new power plants,
  - substituted operation of ICE vehicles and
  - end of life of old vehicles.
- „Climate Neutrality“ with addressing the limited GHG budget for Paris Agreement is only possible on basis of dynamic LCA.

## 2.9 Dissemination Activities

The following dissemination and exploitation activities took place:

- Presentations:
  - *Experiences of in the IEA Collaboration Program on Hybrid and Electric Vehicles (HEV), EV2019 - Electric Vehicles International Conference & Show, October 3-4, 2019 in Bucuresti, Romania*

- *Prüfstand „Lebenszyklusanalyse“: Klima- und Energiebilanz von Transportsystemen (Test Bench „Life Cycle Assessment“ – GHG and Energy Balance of Transportation Systems), Symposium ZUKUNFT Gas-MOBILITÄT 2020; March 11 – 12, 2020*
- *Most Climate-Friendly Propulsion with Renewable Fuel - Biofuel, Electricity, Hydrogen or e-Fuels; ECO-Mobility – Virtual A3PS-Conference 2020*
- *Climate Friendly Biofuels in Comparison to Other Fuels, Renewables in Transport, Expert Talk, January 21, 2021, online*
- *Climate Friendly Biofuels in Comparison to Other Fuels, Renewables in Transport, Expert Talk, January 21, 2021, online*
- *LCA Application to Growing EV-Fleets with Increasing Supply of Renewable Electricity – Methodological Aspects and Assessment for GHG Emissions of BEV Introduction in Austria, IEA HEV Task 30 meeting, online, February 3, 2021*
- *Greenhouse Gas and Energy Balance in the Life Cycle of Passenger Vehicles – Comparing E-Fuels and Electricity; E-Fuels oder Verbrenner-Verbot?, Die Mobilitäts-Politik der EU am Scheideweg, 28.4.2021, online*
- *GHG-Emissions of Additional Renewable Electricity in Austria and its Consequences on the Introduction of Electric Vehicles in a Dynamic LCA, IEWT 2021, September 9 – 11, 2021, Vienna, Austria*
- *Life Cycle Analysis of BEV and ICE, SEAI National Energy Research & Policy Conference, November 25, 2021, Ireland*
- *Scenarios for a Climate Neutral Vehicle Fleet in Austria Using Dynamic LCA, 17. Symposium Energieinnovation, 16.-18. Februar 2022, Graz, Austria*
- *Renewable Energy for Climate Friendly Lifestyles - Example Mobility Services with Battery Electric Vehicles; for RENEWABLEMEET2022 - International Meet on Renewable and Sustainable Energy March 21-25, 2022, Dubai, UAE*
- *Lessons Learnt in IEA HEV Task 30 - Recent Findings on the LCA of Electric Vehicles and its Possible Contributions to Climate Neutrality, 4<sup>th</sup> Conference on Local E-mobility, April 13, Brno, Slovenija*
  
- *Klimaneutrale Mobilität in Österreich – Methoden, Fakten und Mythen, 5. Europäisches Forum Alpbach 2022, Session 7: Kreislauffähige und klimaneutrale Mobilität - Herausforderungen und Lösungen am Beispiel Fahrzeug, 26. August 2022*
  
- Presentation & paper
  - *LCA Based Estimation of Environmental Effects of the Global Electric Vehicles Fleet - Facts&Figures from the IEA Technology Collaboration Program on Hybrid&Electric Vehicles, Transport Research Arena TRA 2018 in Wien, 16-19 April 2018*
  - *Water Issues and Electric Vehicles - Key Aspects and Examples in Life Cycle Assessment, EVS31 – Electric Vehicle Symposium, Kobe, Japan, Sept. 30 – Oct 3, 2018*



- *Time and Rebound Effects in the LCA of Electric Vehicles - Methodological Approach and Examples*, IEWT 2019, Vienna University of Technology, February 13 – 15, 2019
- *Evaluation of the Environmental Benefits of The Global EV-Fleet in 40 Countries – A LCA Based Estimation in IEA HEV*, EVS32 – Electric Vehicle Symposium Lyon, France, May. 19 – 22, 2019
- *Climate Neutrality of Growing Electric Vehicles Fleets (2010 - 2050) in a Dynamic LCA Considering Additional Renewable Electricity: Example Austria*, EVS35 Symposium Oslo, Norway, June 11-15, 2022
- Poster
  - *Environmental Effects of Electric Vehicles Globally - An Assessment in IEA HEV Task 30*, A3PS Conference 2018 “Future Propulsion Systems: Different Regions - Different Strategies - Different Solutions”, November, 12 - 13 2018, Vienna, Austria
  - *Scenarios for a Climate Neutral Passenger Vehicle Fleet in Austria 2040 Using Dynamic LCA*, ECO-Mobility – A3PS-Conference 2021, November 18-19, 2021, Vienna, Austria
- Lecture:
  - *Electric Vehicle Lecture - Environmental Impacts of Electric Transport*, MSc Program “Renewable Energies” of Vienna University of Technology, online, February 13, 2021
- Presentation and working document:
  - *LCA Application to Growing EV-Fleets with Increasing Supply of Renewable Electricity – Methodological Aspects and Assessment for GHG Emissions of BEV Introduction in Austria*, IEA HEV Task 30 meeting, online, February 3, 2021
- Publications:
  - *An international dialogue about electric vehicle deployment to bring energy and greenhouse gas benefits through 2030 on a well-to-wheels basis*, Transportation Research Part D 74 (2019) 245–254
  - *Environmental Life Cycle Impacts of Automotive Batteries Based on a Literature Review*, Energies 2020, 13(23), 6345; <https://doi.org/10.3390/en13236345>
  - *GHG Emissions and Primary Energy Demand of Vehicle Fleets Based on Dynamic LCA Methodology – Introduction of Electric Vehicles in Austria 2010 – 2050*, 13<sup>th</sup> International Colloquium Fuels, September 15-16, 2021, Esslingen, Germany
- Working document of Task 30:
  - *Rebound Effects of Electric Vehicles and Possible Implication on Environmental Effects in LCA of Electric Vehicle*, status February 2021
  - *LCA Application to Growing EV-Fleets with Increasing Supply of Renewable Electricity – Methodological Aspects and Assessment for GHG Emissions of BEV Introduction in Austria*, status February 2021
- Contributions to the IEA HEV Annual Reports 2017, 2018, 2019, 2020, 2021 and 2022

- IEA HEV Newsletter
  - Contributions #1, #2 and #3 in 2021 and #1 in 2022
- Abstracts submitted
  - *Ökobilanz eines e-Bikes im Vergleich zum konventionellen Fahrrad*, 13. Österreichischer Radgipfel, 3. - 5. April 2022, Vienna, Austria; not accepted

## 3 Conclusions

### 3.1 Lesions Learnt

Based on the current trends the main challenges and R&D demand for electric vehicles are summarized and described.

#### 3.1.1 Overview

The conclusion from the task work can briefly be summarized in the following 10 lessons learnt:

1. Methodology for Environmental Assessment: LCA not WtW,
2. System Boundary,
3. Systematic of Transportation Systems,
4. Main Factors Influencing LCA Results,
5. Possible Impacts and Impact Assessment Methodologies,
6. Minimum Requirements on Impact Assessment,
7. Main Water Issues in LCA of ICE and EV,
8. Recommendations for LCA of BEV, PHEV and ICE,
9. Potential Rebound Effects of EVs and
10. Dynamic LCA and Vehicle Fleets for Climate Neutrality 2050.

#### 3.1.2 Methodology for Environmental Assessment: LCA not WtW

There is now an international consensus that the environmental effects of transportation systems can only be analysed and compared on the basis of LCA including the production, operation and the end of life treatment of the various facilities. Other methodologies like Well-to-wheel (WtW) or methodologies used in legislation, like in the Renewable Energy Directive in Europe, do only cover parts of the relevant stages in the lifecycle of a vehicle and its energy supply. These other methodologies exclude environmental effects from vehicle production and its end of life as well as the construction and dismantling of facilities to supply energy, e.g. electricity generation with wind and PV.



In Figure 29, the description of life cycle assessment is given, which must follow at least the guidelines given in ISO 14,044 with the phases of an LCA:

- 1) Goal and Scope Definition,
- 2) Inventory Analysis,
- 3) Impact Assessment and
- 4) Interpretation.

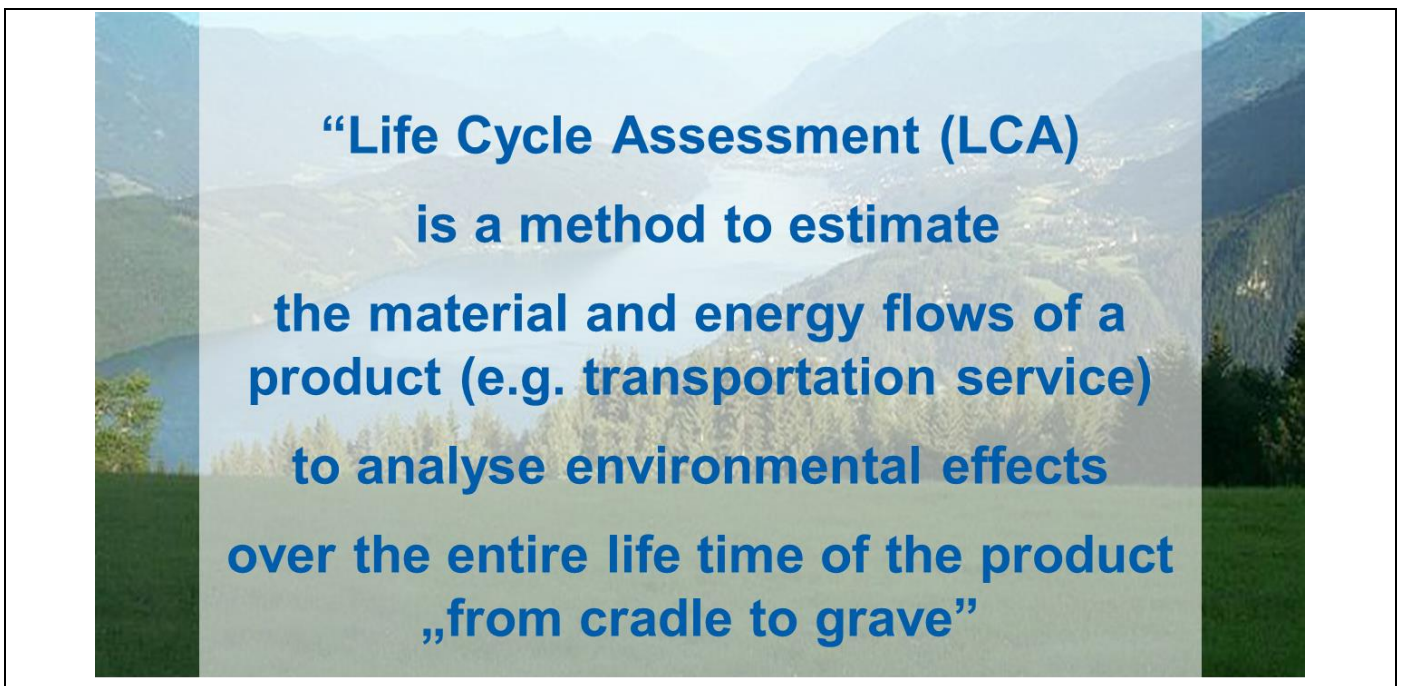

Figure 29: Lesson learnt #1: LCA is the only methodology for Environmental Assessment of EVs

### 3.1.3 System Boundary

The LCA of EVs and ICEs must cover the three phases in their life cycle:

1. production phase
2. operation phase and
3. end of life phase.

In the production phase, all components of the vehicle are relevant and for EVs especially the battery production is relevant. The operation phase covers the energy fuel supply, the maintenance, the auxiliary materials (e.g. add blue, lubricant oil) and spare parts. The end of life phase covers all recycling and use activities to provide secondary material and/or energy. All the energy and material inputs are based on their process chain starting with the natural resources.

In Figure 30, the system boundaries for an LCA of EVs is given, starting with natural resources for electricity generation (e.g. hydro, raw oil, coal) and ending with the supply of a transportation service. The main processes are:

- power plant (incl. coproduct heat from CHP power plants),
- electricity grid,
- storage system to balance - if necessary - the electricity supply and the electricity demand for charging,
- the charging station and
- the vehicle.

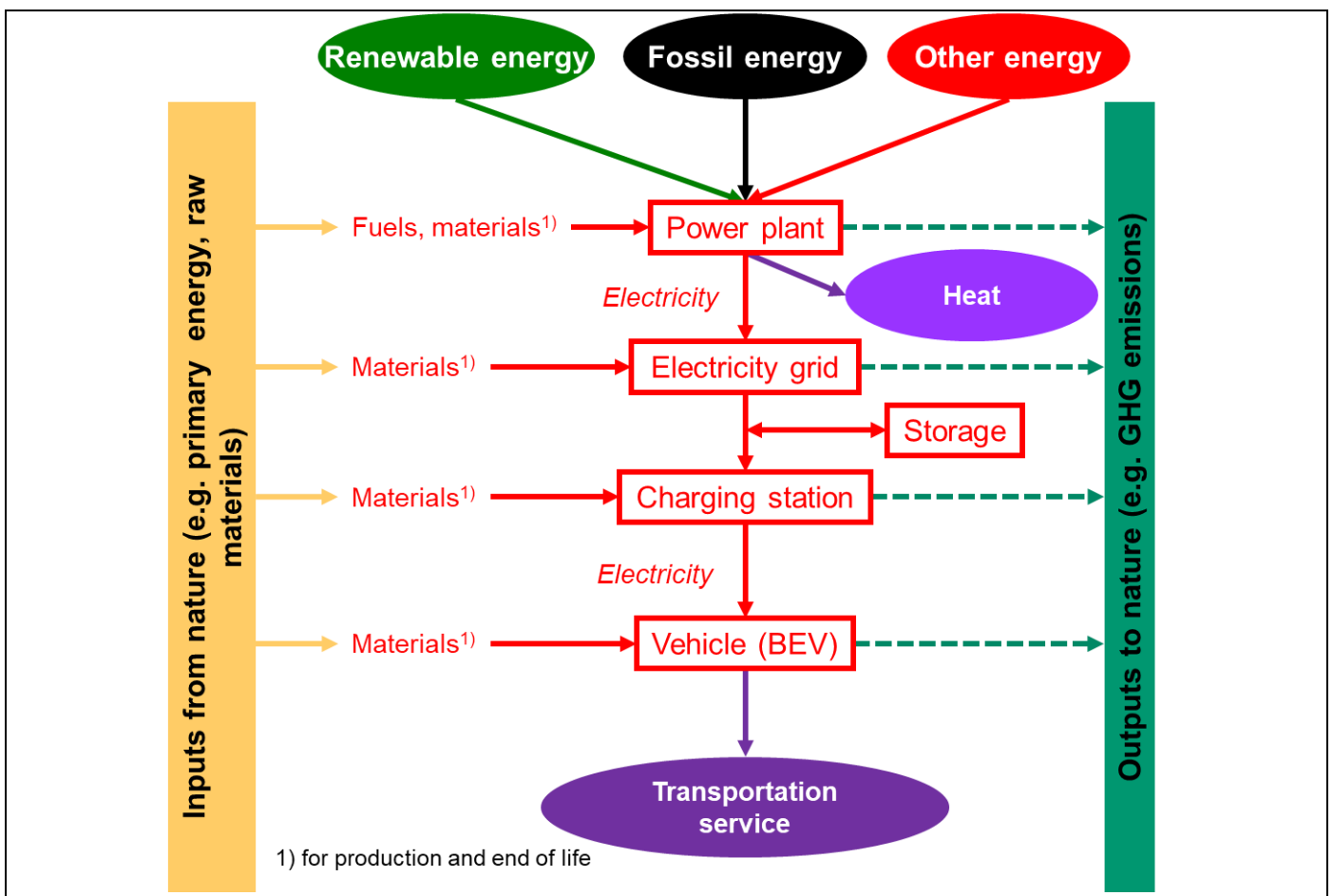

Figure 30: Lesson learnt #2: System boundaries

### 3.1.4 Systematic of Transportation Systems

The transportation system analysed must be characterised exactly by the following 6 criteria (Figure 31):

- type of vehicle,

- propulsion system,
- fuel/energy carrier,
- type of primary energy,
- state of technology and
- country.

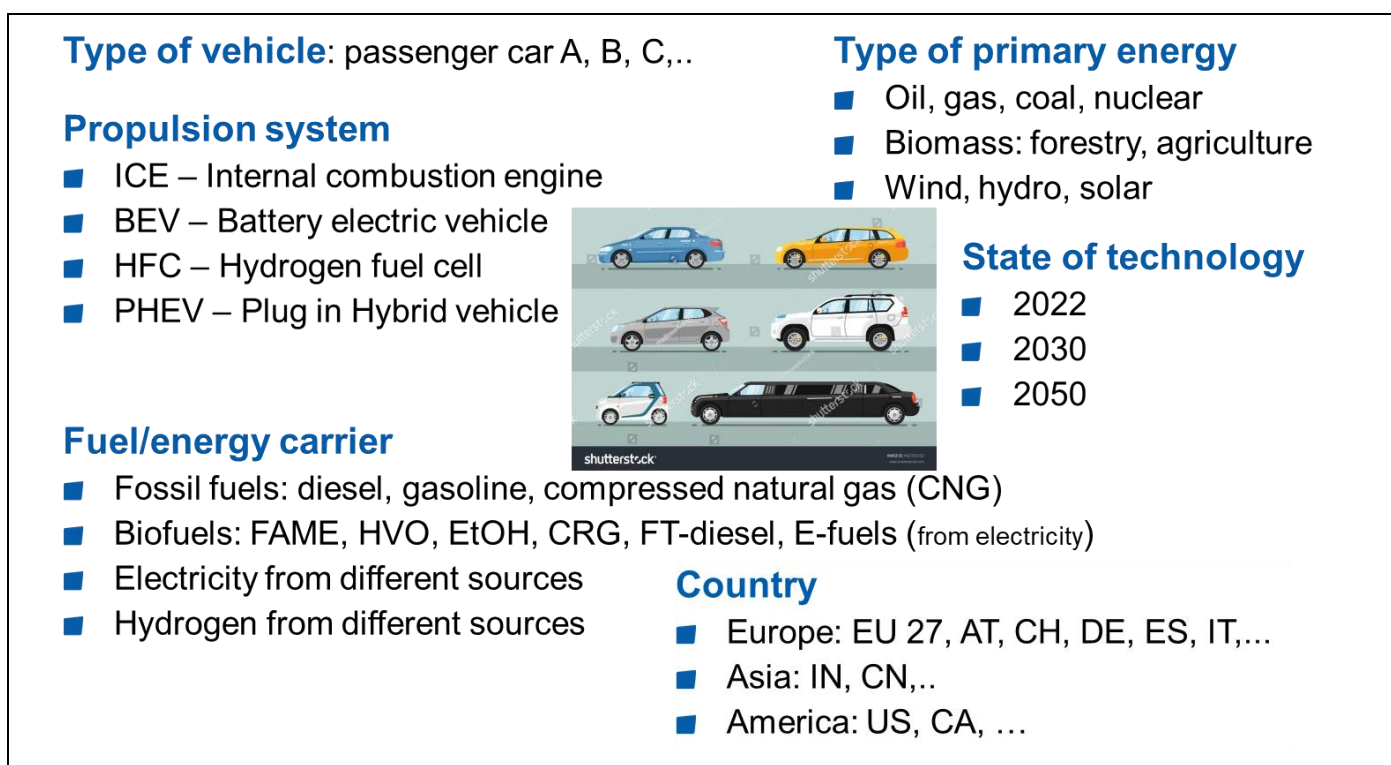

Figure 31: Lesson learnt #3: Systematic of transportation systems

### 3.1.5 Main Factors Influencing LCA Results

The main influencing factors in LCA of vehicles are:

- source of electricity generation and its future development up to 2030/2050,
- lifetime mileage,
- energy consumption of vehicle (incl. heating, cooling, auxiliaries) and electric share for PHEV,
- battery:
  - production: country, production capacity, source of electricity,
  - battery capacity,
  - end of life (material recycling or reuse in 2<sup>nd</sup> life),

- biofuels:
  - direct land use effects (dLUC),
  - indirect land use effects (iLUC),
  - type of feedstock (e.g. from agriculture, forestry or industrial residues),
- e-fuels:
  - source of CO<sub>2</sub>,
  - „carbon neutral“ only using CO<sub>2</sub> from air and sustainable biomass.

### 3.1.6 Possible Impacts and Impact Assessment Methodologies

The way from Inventory Analysis to Impact Assessment is via mid- and end-point indicators. With regard to the geographical scope of the different impacts, the mid-point indicators are grouped for global, regional and local impacts. The mid-point indicators on these geographical scopes are:

- global:
  - climate change,
  - ozone depletion,
  - primary energy use (consumption) (fossil and renewable),
  - resource use, minerals and metals,
  - water footprint (based on inventory level method),
  - land use (focus on inventory data),
- regional:
  - acidification,
  - photochemical ozone formation,
  - smog formation,
  - eutrophication, terrestrial, freshwater and marine,
  - ionising radiation,
- local:
  - human toxicity, cancer and non-cancer,
  - particulate matter,
  - land use,
  - water scarcity,
  - biodiversity and
  - ecotoxicity, fresh water aquatic, marine aquatic and terrestrial.

Water and land use were allocated to the global and to the regional level, whereas on global level mainly results from inventory analysis are relevant, whereas on local level a very distinctive methodology might be applied for local impact assessment based on very localized data.

The end-point indicators, which are always assessed on global scale, are:

- protection areas:

- human health,
- ecosystem health,
- resource availability and
- external costs.

Due to the methodological complexity and uncertainty, the practical addressing and calculation of “end-point indicators” are not recommended for LCA of EVs and conventional vehicles.

The main relevant impacts with current state of impact assessment methodologies using available and robust inventory data in LCA are mainly for global impact categories.

These main global impact categories for transportation systems are:

- climate change,
- primary energy use (consumption) (fossil and renewable),
- resource use minerals and metals,
- water footprint (inventory level),
- ozone depletion and
- land use (inventory level).

### 3.1.7 Minimum Requirements on Impact Assessment

The minimum requirements in the impact assessment to compare different vehicles are the:

- GHG emissions in CO<sub>2</sub>-equivalent with its share of CO<sub>2</sub>, CH<sub>4</sub> and N<sub>2</sub>O and
- primary energy demand in e.g. MJ with its share of fossil or renewable energy.

To illustrate these minimum requirements the LCA results are shown using wind electricity to provide transportation service with different propulsion and fuel systems (H<sub>2</sub> fuel cell, BEV and ICE with e-fuel) in comparison to petrol and diesel in [Figure 32](#). Of course, the GHG emissions are lower if renewable energy is used, but the primary energy demand gives information about the vehicle with the highest energy efficiency from primary energy to transportation service, e.g. BEV are most energy efficient.



## GHG emissions and Primary energy demand

**Example:  
Using Wind Energy for H<sub>2</sub>-FCV, E-fuel and BEV passenger vehicle**

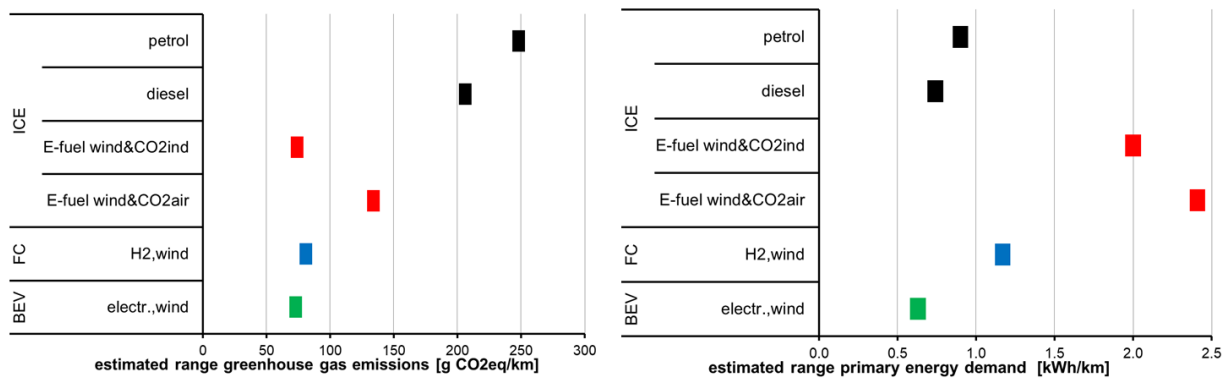

Figure 32: Lesson learnt #5: GHG emissions and primary energy demand as minimum requirements in impact assessment

### 3.1.8 Main Water Issues in LCA of ICE and EV

The main water issues in LCA of ICE and EV identified so far are:

- ICE (incl. blending of biofuels):
  - fossil fuel extraction and refining,
  - cultivation of feedstock for biofuels, e.g. for biodiesel (B5), bioethanol (E10),
  - vehicle production,
- EV (BEV and PHEV):
  - electricity generation (e.g. thermal open/closed cycle, hydro power),
  - battery production and
  - vehicle production.

### 3.1.9 Recommendations for LCA of BEV, PHEV and ICE

The main global impacts should be addressed (in future) (Figure 33):

- climate change,

- primary energy use (fossil and renewable),
- resource use minerals and metals,
- water footprint (inventory level),
- land use (inventory level).

For EVs (incl. batteries) and renewable electricity generation the type and amount of material used in the construction phase becomes more relevant than for conventional vehicles using raw oil. Therefore, the impact category of “Resource use, mineral and metals” becomes a more relevant global impact category. Concluding, an advanced requirement for LCA should be to calculate the amount of material in the inventory analysis especially for the most relevant materials like Cu, Li, Co, Ni, Mn and others. Based on the inventory the resource use should be assessed based on kg Sb-eq and giving the main contributions from single minerals or metals.

Water issues are also relevant, especially for mining activities, lithium extraction and hydro power. So on global scale the Water Footprint using the inventory based methodology should be assessed in future LCA of EVs and ICEs.

In addition, land use aspects are relevant for mining of raw materials as well as for renewable electricity production. As a next step in LCA of EVs the amount of land or land occupation over time should be analysed in the inventory phase by at least differentiation on the type of land: agriculture, forestry, infrastructure, industrial area or any other type of land.

The results on the considered global impact categories should be documented and communicated not only for the total value but also for the three main phases in the life cycle of a transportation system:

- production:
  - Vehicle,
  - energy/battery storage,
- operation:
  - fuel/energy supply,
  - fuel use,
  - maintenance,
- end of life:
  - recycling and/or reuse and
  - substitution of secondary material.

The main influencing parameters on the global impacts should be identified and described.



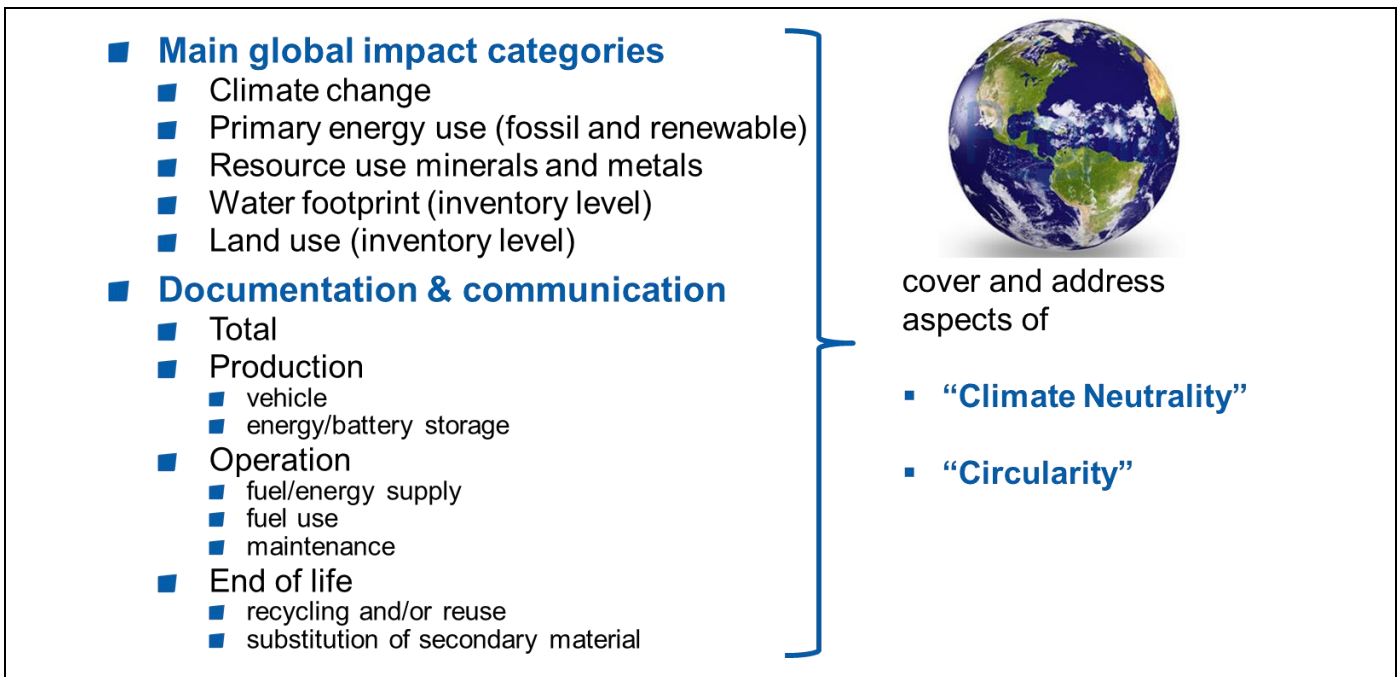

Figure 33: Lesson learnt #8: Main global impacts and documentation requirements

### 3.1.10 Potential Rebound Effects of EVs

In LCA of EVs and conventional ICE vehicles the environmental effects are given for the functional unit of 1 driven kilometre, in comparison to other transportation modes like buses, trains and trams the functional unit is often per passenger kilometre. Depending on the goal and scope of the LCA, also the annual environmental effects or the cumulated effects over the lifetime are relevant.

LCA methodology according to ISO 14,040 defines the functional unit as the basis for comparison of environmental effects of different systems, which provide the same service or function. Therefore, in the comparison based on LCA it is assumed that the functional unit or service of a system can be provided and substituted by another system. However, due to possible rebound effects, it is possible that a system A cannot substitute a system B for 100%. That is why in LCA of EVs especially for EV fleets it must be proven that no rebound effects are possible, or rebound effects have to be considered.

The possible rebound effect can be considered in LCA by the definition of the functional unit and the substitution rate. In reflecting possible rebound effects in comparing the environmental effects of EVs with conventional ICE vehicles the following issues are relevant and have to be analysed and described referring to possible different uses of the vehicles:

- number of substituted ICE vehicles,
- substituted other transportation modes e.g. public transport, walking,
- different annual mileage,
- vehicle lifetime and



- driving distance with one charging or refill.

These aspects must be considered carefully by defining the functional unit. The possible conclusion might be that the substitution rate is not 100%, it could be in most cases less than 100% but in specific cases also more than 100%, saying that 1 electric driven kilometre substitutes more than 1 fossil ICE driven kilometre.

The analysis of these issues should be documented in LCA to argue for the chosen substitution rate.

Current experiences in considering rebound effects in LCA show that these are most relevant by considering environmental effects of whole vehicle fleets over time and future scenarios for the development of environmental benefits of EVs in scenarios for transportation services and or mobility systems. In these cases, the influence of possible rebound effects have to be reflected in LCA. A recommendation for practical application is to make sensitivity analyses on various substitution rates to identify the order of magnitude on the final results.

### 3.1.11 Dynamic LCA and Vehicle Fleets for Climate Neutrality 2050

Issues on dynamic LCA, e.g. annual environmental effects, become relevant for the rapidly increasing of EV fleets combined with an additional generation of renewable electricity. Therefore, the Task identified the following relevant methodological aspects:

- timing of environmental effects in the three lifecycle phases,
- timing of environmental effects of increasing supply of renewable electricity,
- timing of environmental effects of EVs using increasing supply of renewable electricity and
- substitution effects and timing of environmental effects of EVs substituting for ICE vehicles.

All environmental effects based on LCA should be calculated and should be shown over time, e.g. a new BEV in 2022 charges changing electricity mix in the years during its life time. Due to climate goals, the electricity mix might change rapidly in future, this must be reflected in the dynamic LCA.

## 3.2 Outlook

The described global indicators also cover and address aspects of the two most relevant environmental aspects currently under public and political agenda e.g. within the GreenDeal:

- “Climate neutrality” and
- “Circularity”.

However, as these aspects are relevant in a dynamic system perspective, e.g. recycling to secondary material, further methodological developments are necessary to integrate them in LCA.

Considering current international LCAs on EVs in comparison to ICE, it becomes obvious that Global Warming and Primary Energy Demand are a minimum requirement and state of the art in impact assessment. LCAs disregarding one of these two impacts are too limited or misleading in their conclusions and interpretations.

It is expected, that the other global impacts - Resource Use, Water Footprint and Land Use – will be analysed and assessed in LCA of EVs in future more often, using the rapid international progress made for inventory data.

Considering the local and regional impact categories in LCA, further methodological developments, better inventory data and general acceptance are necessary. Alternatively, these environmental impacts (e.g. biodiversity) will be addressed with other methodologies than LCA more adequate in future.

The new IEA HEV TCP Task 46 (2022 – 2024) “LCA of electric Trucks, Buses, 2-Wheelers and other Vehicles” will address these global impact categories further and intends to develop and discuss new approaches to address “Climate Neutrality” and “Circularity” of transportation system in (dynamic) LCA.

## Annex 1: Expert Workshop on Water Issues

*“There is international consensus that the environmental effects of electric vehicles can only be analyzed on the basis of Life Cycle Assessment (LCA) including the production, operation and the end of life treatment of the vehicles in comparison to conventional vehicles”*

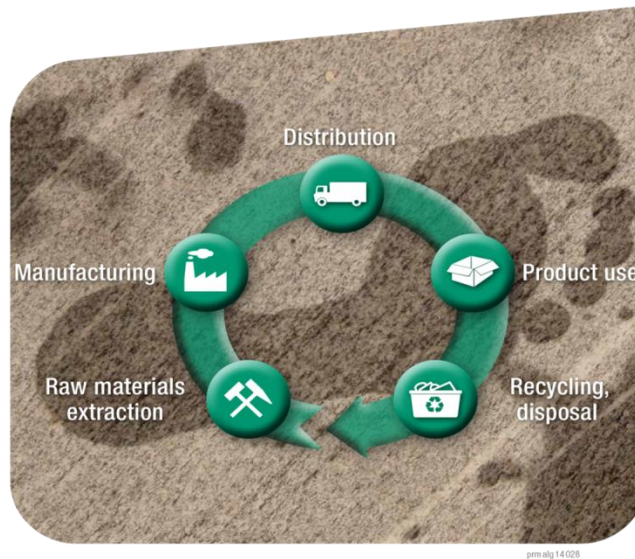

## Environmental Effects of Electric Vehicles (EV)

### Water Issues and Benefits of EV-Fleets on Energy Consumption and Air Emissions

*Documentation of the Expert Workshop*



JOANNEUM RESEARCH  
LIFE

**Graz, Austria**  
**January 12 – 13, 2017**

JOANNEUM RESEARCH  
 Leonhardstrasse 56  
 A-8010 Graz

**Local organisers:**

JOANNEUM RESEARCH

Gerfried Jungmeier, [gerfried.jungmeier@joanneum.at](mailto:gerfried.jungmeier@joanneum.at)

## Content

1	Introduction .....	2
2	Aim of the workshop.....	3
3	Examples for water issues.....	4
3.1	Electricity production .....	4
3.2	Comparing EV and ICE .....	7
4	Identification of key issues for water in LCA of EVs .....	8
4.1	Where in the value chain of EVs and ICEs water issues are most relevant? .....	9
4.2	What are the most relevant water issues? .....	9
4.3	What are the main methodological aspects to judge on water issues? .....	9
4.4	What are the main relevant water impact categories? .....	10
4.5	What is the “Water footprint”? and what is its relevance compared to Carbon Footprint? .....	10
4.6	Which data on water do we need to assess these main issues? .....	10
4.7	What are the main research questions water issues for EVs and ICEs?.....	11
4.8	What are the main institutions and publications on water issues of EVs and ICEs?11	
4.9	What could be a common activity on water issues in IEA HEV 30? .....	11
5	Conclusions.....	12

## ANNEX:

- Program
- Participants
- Abstracts of presentations:
  - Water Consumption Factors for Electricity Generation in the United States
  - Addressing Water Consumption and Degradation in LCA – Methodology and Examples
  - LCA of innovative Li-S batteries for electric vehicles
- Results of Group work on main assumptions and key issues of assessing current and future EV fleets
- Presentations (extra pdf file)

## 1 Introduction

Electric vehicles have the potential to substitute conventional vehicles and contribute to the sustainable development of the transportation sector worldwide, for example, in the reduction of greenhouse gas (GHG) and particulate emissions. There is international consensus that the improvement of the sustainability of electric vehicles can only be analysed on the basis of life cycle assessment (LCA) (Figure 1), which includes the production, operation, and the end-of-life treatment of the vehicles and the fuel cycle. All environmental impacts from the whole value chain must be assessed and - if relevant - interactions from recycling in the

dismantling phase to the production phase and if recycled material is used to produce new vehicles should be included

The Technology Collaboration Program on “Hybrid and Electric Vehicle (HEV)” of the International Energy Agency (IEA) is operating the Task 30 “Assessment of Environmental Effects of Electric Vehicles” to examine the environmental effects of vehicles with an electric drivetrain based on life cycle analyses. The Task 30 started in 2016 and will continue until the end of 2019. The main activities influencing the environmental impacts of electric vehicles, on a life cycle basis, are:

- 1) Production and life time of the battery,
- 2) Electricity consumption by the vehicle in the operation phase, incl. e.g. energy demand for heating,
- 3) Source of the electricity, only additional renewable electricity maximizes the environmental benefits and
- 4) End of life treatment of the vehicle and its battery.

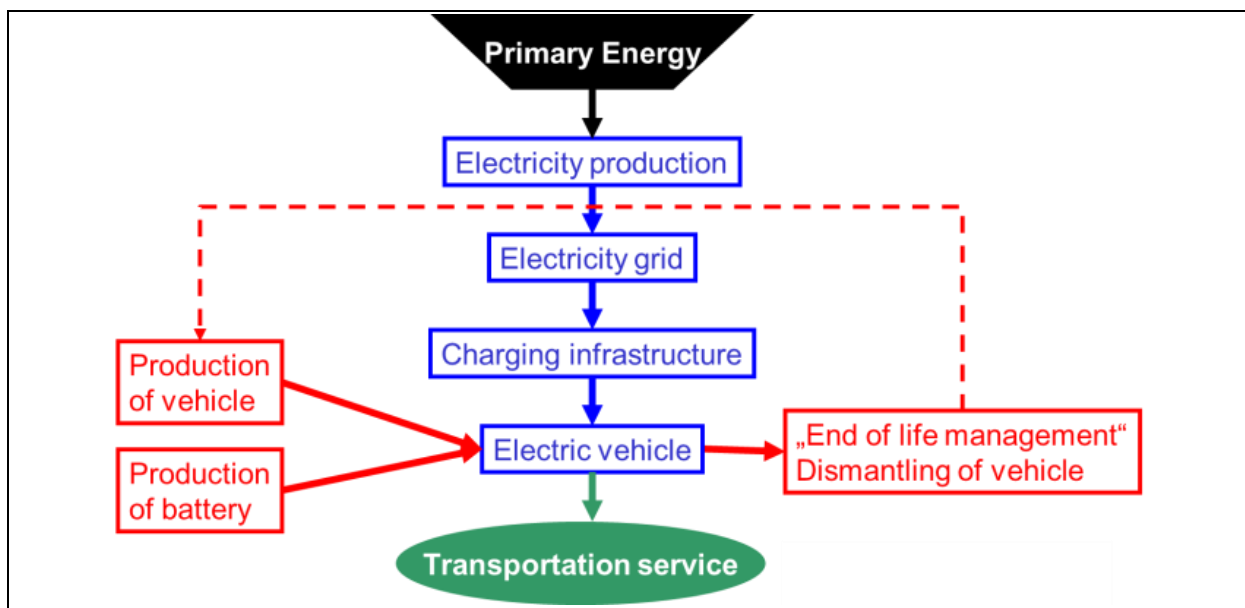

Figure 1: Key elements of the life cycle assessment of vehicles with an electric drive train

## 2 Aim of the workshop

In January, 2017 Task 30, in a cooperation of the participating countries in the International Energy Agency (IEA), held an expert workshop on the environmental effects of electric vehicles (EVs) on water, energy consumption and air emissions based on life cycle assessment.

The aim of the workshop was to present and discuss the current status and the future perspectives of the environmental performance of Electric Vehicles in comparison to conventional vehicles with an internal combustion engine (ICE) in a life cycle perspective.

The main focus is on Battery Electric Vehicles (BEV) and Plug in Hybrid Electric Vehicles (PHEV).

The results of the activities of LCA activities in IEA HEV since 2012 and recent developments in LCA methodology development and its application to EVs were presented.

The two topics for the workshop were:

1. Water Issues and
2. Benefits of EV-Fleets on Energy Consumption and Air Emissions.

The format of the workshop was based on presentations, discussion and group work with focus on

- Data requirements
- Case studies
- Identification of main issues in LCA of EVs and ICE
- Identification of “hot spots” on water issues of EVs, PHEVs and ICEs
- Communication of LCA results to stakeholders, e.g. Fact Sheet
- Findings and Recommendations

A summary of the presentation and discussions follow in the next sections.

### 3 Water issues

The examples for water issues of electricity production and the comparison of EV and ICE were presented and discussed at the workshop.

#### 3.1 Electricity production

In Figure 2 to Figure 5 the water consumption of electricity production is shown. The water consumption is mainly relevant for thermal power plants and hydro power plants. For thermal power plants the water consumption mainly depends on the type of cooling technology, whereas for hydro power the allocation of the water consumption to the different purposes of a hydro dam (e.g. electricity, flood control, navigation, recreation, and irrigation) is most influencing.

The total environmental damage (e.g. "Eco-Indicator 99" (Ei 99+), Figure 6) comparing different electricity generation systems might lead to two findings:

- 1) Water is most relevant for hydro power but
- 2) The total environmental damage of hydro power is significantly lower compared to natural gas and coal.



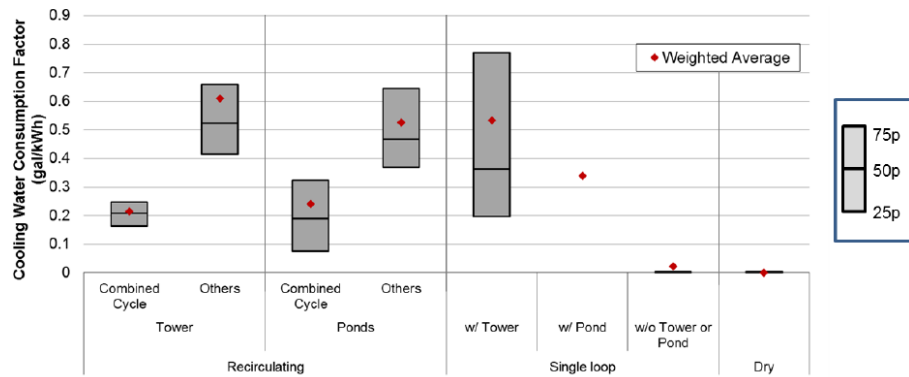

Figure 2: Water consumption factor by cooling technology for thermoelectric generation (Elgowainy 2017)

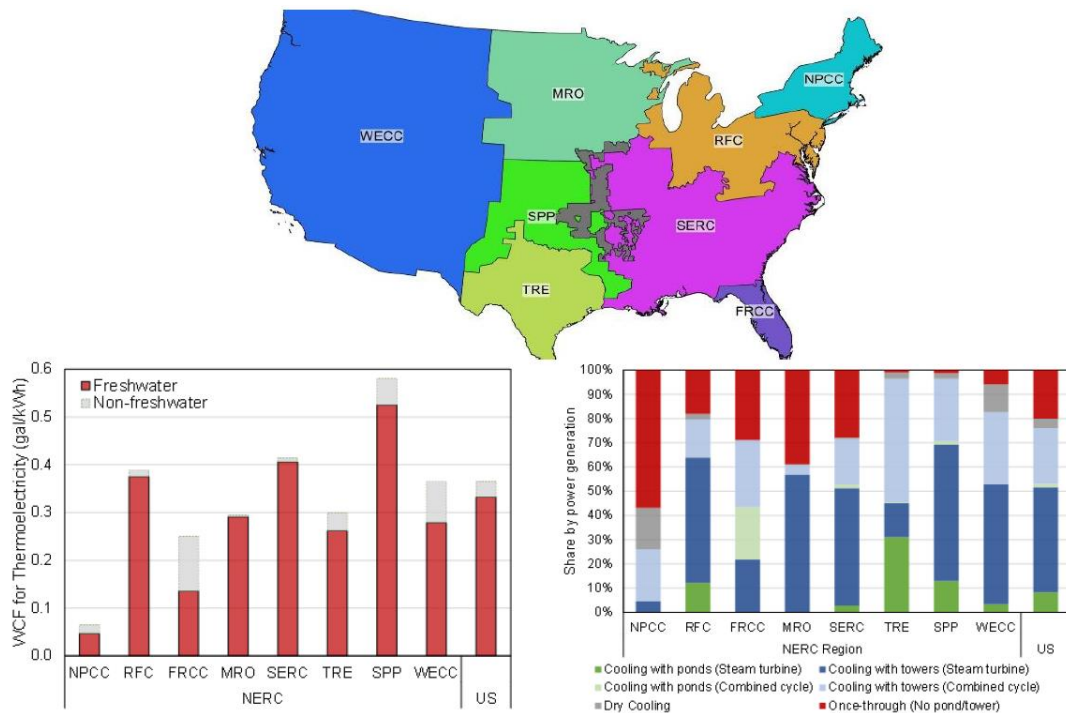

Figure 3: Cooling water consumption of thermoelectric generation by utility regions in the USA (Elgowainy 2017)



Power Generation Share

Thermoelectricity	83%	96%	98%	77%	96%	90%	82%	66%	87%
Hydropower	13%	1.1%	0.7%	5.2%	3.4%	0.2%	1.8%	22%	6.3%

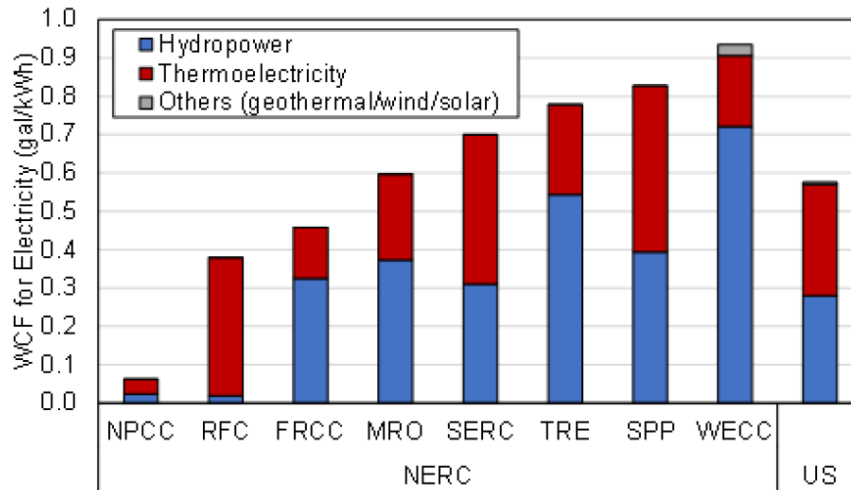

Figure 4: WCF for total electricity generated by utility regions in the USA (Elgowainy 2017)

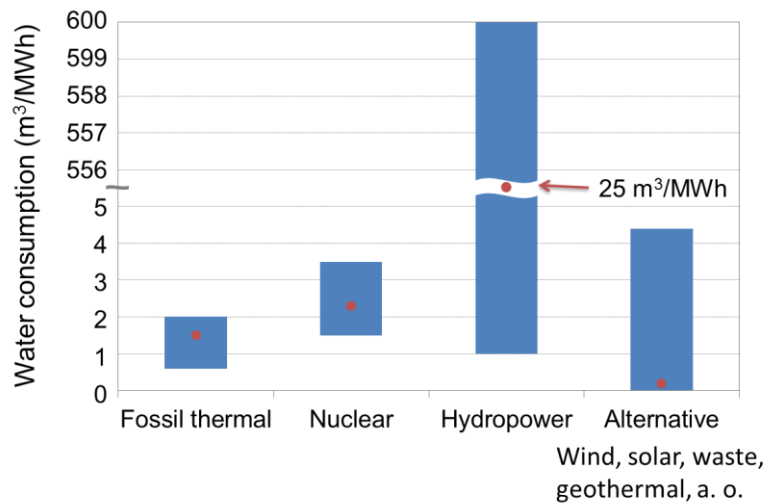

Figure 5: Water consumption of main power production technologies (Pfister et al. 2011)

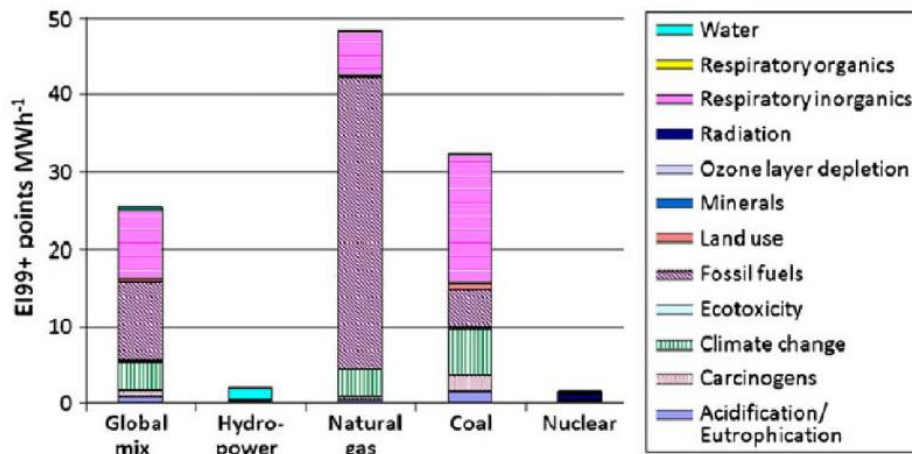

Figure 6: Environmental damage of power production (Pfister et al. 2011)

### 3.2 Comparing EV and ICE

The comparison of water issues of EV and ICE shows that the life cycle based water consumption of EV might be higher than from ICE. The main reason is the electricity production from hydropower and thermal power plants. For ICE the most relevant influence on water consumption depends on the amount of biofuel blended (biodiesel in diesel or bioethanol in gasoline), as the agricultural production of the feedstock for biofuels is most relevant for water issues, e.g. most of the water consumption for E10 gasoline ICE vehicle in the USA derives from corn cultivation for bioethanol.

The comparison of water withdrawal and consumption for fuel supply show that

- for the ICE about 50% of the water withdrawal and about 80% of the water consumption is needed for the gasoline supply
- for the EV about 90% of the water withdrawal and about 80% of the water consumption is needed for the electricity supply.

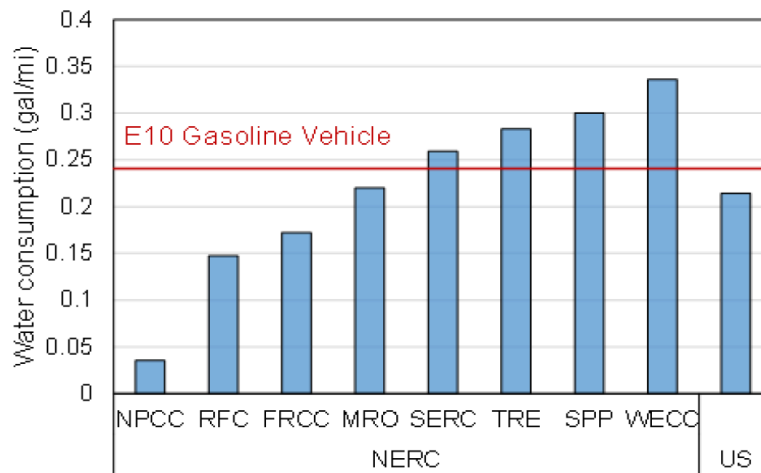

E10 gasoline vehicle: midsize vehicle, 26 mpg for gasoline, 94 mpg for BEV

Figure 7: Life cycle (WtW) water consumption of EVs versus gasoline ICEVs (Elgowainy 2017)

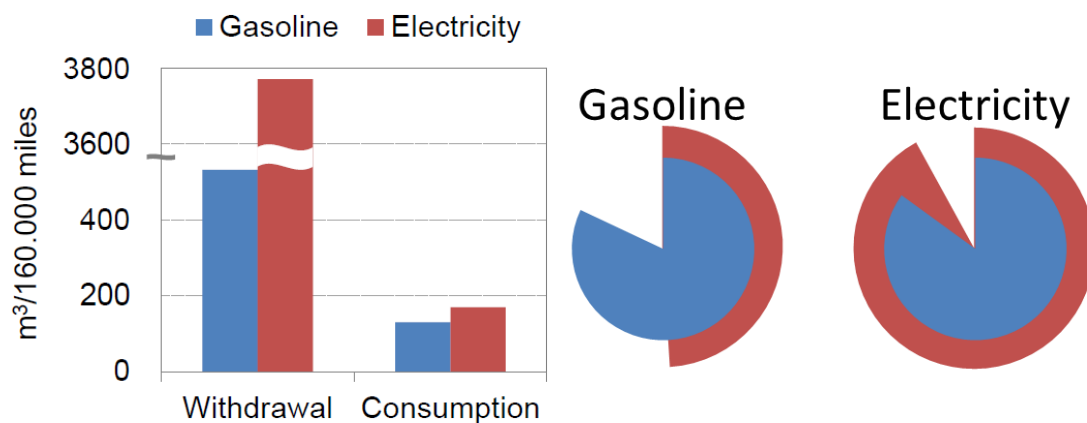

Figure 8: Comparison of Ford Focus gasoline and electric vehicle (left) and Contribution of fuel / electricity production to water use (right)(Kim et al. 2015)

#### 4 Identification of key issues for water in LCA of EVs

In an interactive group work the following seven questions were discussed and the main results were documented.

- Where in the value chain of EVs and ICE are water issues most relevant?
- What are these most relevant water issues?
- What are main methodological aspects to judge on water issues?
- What are main relevant water impact categories? E.g. blue, green?
- What is the “Water footprint”? And its relevance compared to “Carbon Footprint”?
- Which data on water do we need to assess these main issues?
- What are the main research questions on water issues of EVs and ICE?
- What are main institutions and publications on water issues of EVs and ICE?
- What could be a common activity on water issues in IEA HEV Task 30?

#### 4.1 Where in the value chain of EVs and ICEs water issues are most relevant?

The following processes are most important for:

- ICE (incl. blending of biofuels):
  - Fossil fuel extraction and refining (e.g. tar sands, oil shale or traditional oil)
  - Cultivation of feedstock for biodiesel and bioethanol (e.g. for B5, E10)
  - Vehicle production
- EV (only BEV and PHEV):
  - Electricity generation (e.g. thermal open cycle, closed cycle, or hydro power)
  - Battery production (specifically because of pollutants for mineral extraction and refining)

#### 4.2 What are the most relevant water issues?

The most relevant water issues for IEA HEV 30 were identified as:

1. Water consumption factor (WCF)
2. Water Stress Index or kind of such an index number
3. Impact assessment (e.g. water quality, thermal pollution)

For the inventory the most relevant issues are:

- Water evaporated (blue water use);
- Water flow alteration (for hydro power)
- Water emissions (impurities that affect water quality)
- Thermal emissions

For the impact assessment, in addition,

- Water scarcity

#### 4.3 What are the main methodological aspects to judge on water issues?

The following methodological issues were raised:

- Allocation for the multiple purposes of hydro dam power like e.g. power, water supply, flood control, navigation, recreation and irrigation
- Temporal variability (both intra and inter-annual) of water
- Water scarcity: Water scarcity is the lack of sufficient available water resources to meet water needs within a region
- Input water quality (source, temperature, quality – salinity and organic loading)
- Discharge water quality (source, temperature, quality – salinity and organic loading)
- Water in auxiliary inputs and (co)products (e.g. steam as a result of natural gas combustion, water is residue streams)
- Assumption of desalinisation of water to replace depleted assets
- System boundary (covering main processes in fuel cycle and vehicle cycle)
- Regional differences (mix of generation/production technologies, cooling technologies, etc.)
- Timeframe (e.g. current, future)
- Consistent models, approaches
- Consistent data/water balance in inventory for all main processes; and
- Consistent water impact assessment

#### 4.4 What are the main relevant water impact categories?

The group decided that only blue water use (i.e. evaporation of water from lakes, rivers or ground water) was relevant.

Grey water use (the amount of water needed to dilute discharge water to an acceptable level) was not of interest. Instead the LCA should be expanded to include proper water treatment (both thermal and toxicity).

#### 4.5 What is the “Water footprint”? and what is its relevance compared to Carbon Footprint?

Carbon Footprint = Greenhouse Gas Emissions \* Global Warming Potential

Water Scarcity Footprint = Water Consumption \* Water Scarcity Index

We decided that water footprint discusses really only volumes and is, as such, on an LCA inventory basis. Carbon footprint, on the other hand, is an LCA impact category. A LCA on water issues requires the water footprint but also water scarcity, eutrophication and toxicity.

Water issues in LCAs should be considered because water is a relevant part of the sustainable development goals and will in future play an increasingly important role. As a result water LCA and carbon footprint should be combined to create DALYs for impact category “Human health” (disability/disease-adjusted life years lost) and PDFs for “Ecosystem quality”.

#### 4.6 Which data on water do we need to assess these main issues?

It is clear that we need data on blue water losses (evaporation and transfer in products) for the inventory, but in addition the following data are needed for a proper water LCA:

- Input water: source, volumes, temperature, quality
- Discharge water: sink, volumes, temperature, quality
- Emissions to water: specifically amounts of N, P, heavy metals and organic loading

The inventory data is needed by

- Region
- Timeframe (current, future)
- Technology
- Uncertainty evaluation
- Original (team) vs. secondary and tertiary data (tools, publications)
- Market scenarios

#### 4.7 What are the main research questions on water issues for EVs and ICEs?

We identified four main topics:

1. How to reduce the water impacts of EVs?
2. Reduction of uncertainties in assessment. This requires:
  - a. Basic data for the inventory at the regional level; and
  - b. Improved data of water inputs and emissions in the construction and dismantling of the EVs
3. Preparedness for the possibility that water becomes a “show stopper”. This requires a proper communication strategy of results and uncertainty of results
4. Including water vapour as a climate forcing

“How a broader use of EVs impacts water stress in a given region?”

Example: *Water consumption* =  $\frac{lH_2O}{kWhproduct} * \frac{kWhproduct}{100 km} * \frac{xkm}{vehicle} * \frac{yvehicles}{market (region)}$

Phase I  
(1) WCF

Phase II  
(1) Stress

#### 4.8 What are the main institutions and publications on water issues of EVs and ICEs?

The group felt that there are no institutions, other than Argonne, that are looking at water LCAs of EVs and ICEs. There are institutions doing water footprints of energy systems and also institutions doing LCA of EVs. The main sources of information on water come from the key driving sectors (i.e. agriculture and energy).

Develop a shared “Box” with folders for each relevant issue – Team will contribute to these folders

#### 4.9 What could be a common activity on water issues in IEA HEV 30?

Two possible short term activities were identified:

1. A communication piece on EVs and water (perhaps similar to or an extension of your existing country based fact sheets)
2. A State of the “Art” of water LCA with respect to EVs which would include research needs (i.e. how to fill the data and methodological “holes”).

A stepwise approach is suggested

- Phase I:
  - Literature search
  - Compile/screen data
  - Filter/downselect data for analysis
  - Focus on WFC



- Phase II:
  - Expand scope to include stress index (or other kind of index) by region/scenario
- Phase III: (maybe out of scope for the IEA HEV 30)
  - Expand scope to include impact assessment (e.g. water quality, thermal pollution, etc.)

## 5 Conclusions

### Main drivers

The key drivers to work on water issues are

- water is a key factor for sustainable development goals
- agriculture (incl. biofuels)
- electricity production in thermal power plant and hydro power plants and
- waste water from industry and population as a pollution of rivers, lakes and seas

### Water inventory

The starting point of an LCA on water issues is a water balance for the most relevant processes of EVs and ICE. Ideally the water balance of each process is closed, as all inputs equal the outputs incl. the transformation of hydrogen into water, e.g. due to a chemical reaction. The water inventory must include the water inputs and water outputs by providing the data on process level with its geographical location

- input water: source, volumes, temperature, quality
- discharge water: sink, volumes, temperature, quality
- emissions to water: specifically amounts of N, P, heavy metals and organic loading

For a proper impact assessment the inventory data including uncertainties are needed by

- region
- timeframe (current, future)
- state of technology
- data source: original, secondary and tertiary data???

### Most relevant water issues for LCA of EV and ICE

- Inventory
  - water evaporated (blue water use);
  - water flow alteration (for hydro power)
  - water emissions (impurities that affect water quality)
  - thermal emissions
- Impact assessment
  - water consumption factor (WCF)
  - water scarcity
  - water Stress Index or kind of such an index number
  - water eutrophication and
  - water toxicity

### “Water footprint”

Water Scarcity Footprint = Water Consumption \* Water Scarcity Index

in analogy to



Carbon Footprint = Greenhouse Gas Emissions \* Global Warming Potential

The commonly often used wording of “*water footprint*” gives only information on the amount of water and is, as such, on an LCA inventory basis, e.g. water consumption. Carbon footprint, on the other hand, is an LCA impact category. An LCA on water issues requires the water footprint but also water scarcity, eutrophication and toxicity.

Water issues in LCAs should be considered because water is relevant part of the sustainable development goals and will in future play an increasingly important role. As a result water LCA and carbon footprint should be combined to create DALYs for impact category “Human health” (disability/disease-adjusted life years lost) and PDFs for “Ecosystem quality”.

#### Water issues in electricity production

The water consumption is mainly relevant for thermal power plants and hydro power plants. For thermal power plants the water consumption mainly depends on the type of cooling technology, whereas for hydro power the allocation of the water consumption to the different purposes of a hydro dam (e.g. electricity, flood control, navigation, recreation, and irrigation) is most influencing.

The total environmental damage (e.g. "Eco-Indicator 99" (Ei 99+) comparing different electricity generation systems might lead to two findings:

- 1) Water is most relevant for hydro power but
- 2) The total environmental damage of hydro power is significantly lower compared to natural gas and coal.

#### Water issues in value chain of EVs and ICE

The following processes are most important in the value chain of EVs and ICE:

- ICE (incl. blending of biofuels):
  - Fossil fuel extraction and refining(e.g. Tar sands, oil shale or traditional oil)
  - Cultivation of feedstock for biodiesel and bioethanol (e.g. for B5, E10)
  - Vehicle production
- EV (only BEV and PHEV):
  - Electricity generation (e.g. thermal open cycle, closed cycle, or hydro power)
  - Battery production (specifically because of pollutants for mineral extraction and refining)

The comparison of water issues of EV and ICE shows that the life cycle based water consumption of EV might be higher than from ICE. Main reason is the electricity production from hydropower and thermal power plants. For ICE the most relevant influence on water consumption depends on the amount of biofuel blended (biodiesel in diesel or bioethanol in gasoline), as the agricultural production of the feedstock for biofuels is most relevant for water issues, e.g. most of the water consumption for E10 gasoline ICE vehicle in the USA derives from corn cultivation for bioethanol.

The comparison of water withdrawal and consumption for fuel supply show that

- for the ICE about 50% of the water withdrawal and about 80% of the water consumption is needed for the gasoline supply
- for the EV about 90% of the water withdrawal and about 80% of the water consumption is needed for the electricity supply.

#### Research questions on water issues & EVs

- How to reduce the water impacts of EVs?

- Reduction of uncertainties in assessment. This requires:
  - basic data for the inventory at the regional level; and
  - improved data of water inputs and emissions in the construction and dismantling of the EVs
- How a broader use of EVs impacts water stress in a given region?
- Preparedness for the possibility that water becomes a “show stopper”. This requires a proper communication strategy of results and uncertainty of results
- Including water vapour as a climate forcing

#### Possible activities of IEA HEV Task 30

The Task 30 might work on the following activities:

- A report giving a summary of the current state of knowledge on water issues in the LCA of EVs covering
  - methodological aspects
  - data issues
  - case studies comparing EVs and ICEs
  - further R&D demand
- Collection and compilation of water consumption (WCF) of global electricity production to analyse and assess water consumption of current global EV fleet. This might than be included in the FACT SHEETS for the IEA HEV countries and worldwide
- Screen methodologies, data and case studies to expand analyses and assessment to include
  - stress index (or other kind of index) by region/scenario
  - impact assessment (e.g. water quality, thermal pollution, etc.)

**ANNEX:**

## PROGRAMM

*Thursday January 12, 2017*

9:30 Welcome

9:45 Introduction - Aims of the Workshop

10:00 – 10:15 IEA HEV Task 30 “**Assessment of Environmental Effects of Electric Vehicles**” (Gerfried Jungmeier, JOANNEUM RESEARCH, A)

### Water Issues

10:15 – 11:00 **Water Consumption Factors for Electricity Generation in the United States** (Amgad Elgowainy, Argonne National Laboratory, USA)

11:00 – 11:45 **Addressing Water Consumption and Degradation in LCA – Methodology and Examples** (Laura Scherer, VU University Amsterdam, NL)

11:45 – 12:30 Discussion

*LUNCH*

13:30 – 15:30 **Group work** on identification of key issues of water in LCA of EVs

*BREAK*

16:00 – 17:00 Presentation and **discussion** of group work

*18:30 Typical STYRIAN DINNER*

### Benefits of EV-Fleets on Energy Consumption and Air Emissions

*Friday January 13, 2017*

9:00 – 9:30 **LCA of Electric Vehicles – The Experiences in Spain** (Gabriela Beneviste, IREC, ES)

9:30 – 9:40 **LCA Guidelines for Determining the Environmental Benefit of Electric Vehicles** (Patricia van Loon, Viktoria Swedish ICT, S)

9:40 – 10:10 **An International Dialogue about Electric Vehicle Deployment to Bring Energy and Environmental Benefits through 2030 on a Well-to-Wheels Basis** (Simone Ehrenberger, DLR, D)

10:10 – 10:40 **Estimated Environmental Impacts of Current EV-Fleet in the USA** (Amgad Elgowainy, Argonne National Laboratory, USA)

10:40 – 11:10 **Country Factsheets on Estimated Environmental Impacts of Current EV-Fleet in 33 Countries** (Gerfried Jungmeier, JOANNEUM RESEARCH, A)

11:10 – 11:20 Discussion

*BREAK*

11:45 – 12:30 **Group work** on main assumptions and key issues of assessing current and future EV fleets

12:30 – 13:00 Presentation and discussion of group work

13:00 – 13:30 **Summary**, conclusions and next steps

*LUNCH*

14:00 – 15:30 Task 30 business meeting (members only)

### PARTICIPANTS

Simone	Ehrenberger	<a href="mailto:simone.ehrenberger@dlr.de">simone.ehrenberger@dlr.de</a>	DLR	Germany
Gabriela	Benveniste Pérez	gbenveniste@irec.cat	IREC	Spain
Gerfried	Jungmeier	gerfried.jungmeier@joanneum.at	JOANNEUM RESEARCH	Austria
Amgad A.	Elgowainy	aelgowainy@anl.gov	ARGONNE	USA
Urte	Brand	Urte.Brand@next-energy.de	NEXT ENERGY	Germany
Marin Juan Felipe	Cerdas	juan.cerdas-marin@tu-braunschweig.de	TU-Braunschweig	Germany
Laura	Scherer	l.a.scherer@vu.nl	VU University Amsterdam	Netherlands
Mario	Grassl	mario.mgrassl@gmail.com	TU Vienna, Renewable Energy	Austria
Maria	Hingsamer	maria.hingsamer@joanneum.at	JOANNEUM RESEARCH	Austria
Neil	Bird	neil.bird@joanneum.at	JOANNEUM RESEARCH	Austria
Patricia	van Loon	patricia.van.loon@viktorija.se	Viktorija Swedish ICT (part of RISE)	Sweden

### Available Abstracts of presentations

## Water Consumption Factors for Electricity Generation in the United States

*Amgad Elgowainy, Argonne National Laboratory*

In many regions of the United States, water availability is of concern due to growing demand and limited supply. In these regions, water is also an essential resource for most power generation technologies. Thermal power plants, which generate 87% of the total electricity in the United States, typically require a large amount of water for cooling purposes. Depending on types of cooling technology and prime movers, water loss or “consumption” through evaporation vary significantly. Hydropower plants with reservoirs “consume” large amount of water through evaporation due to the typically large surface area of the reservoir. Because water consumption rates vary by region due to different climate conditions, regional variation of water consumption due to hydropower generation should be considered. The objective of this study is to estimate the water consumption factor (WCF) for electricity generation, which is defined as the water consumed per unit of power generation (e.g., gallons of water per kWh of generated electricity). In particular, this study evaluates the variation in WCF by region. For hydropower, water consumption from hydropower reservoirs is calculated using reservoir’s surface area, state-level water evaporation data, and background evapotranspiration. Note that water consumption in multipurpose reservoirs is allocated to hydropower generation based on the share of the economic benefit of power generation among benefits from all other purposes (e.g., irrigation, flood control, navigation, etc.) Thus, the balance of water consumption is allocated among all other purposes based on their estimated economic benefits. For thermal power plants, the WCFs by types of cooling technology and prime mover are estimated. Because cooling technologies and prime mover types vary by region, the WCF for thermal power generation also exhibits regional differences. The WCFs from hydropower and thermal power generation are aggregated to

the national-level and also to each North American Electric Reliability Council (NERC) utility region. The national average WCF for electricity is estimated at 0.58 gal/kWh considering the average U.S. electricity generation mix in 2015. At a facility-level, the WCFs of thermoelectricity and hydropower are 0.33 and 4.4 gal/kWh, respectively, while the shares of thermo- and hydro-power generation are 87% and 6.3%, respectively. The WCFs have been implemented in the Greenhouse gases, Regulated Emissions, and Energy use in Transportation (GREET®) model developed by Argonne National Laboratory. GREET is a life cycle analysis tool that evaluates energy use and emissions, as well as water consumption on a life cycle basis. This study allows researchers to analyze lifecycle water consumption for various energy production and conversion pathways. While the economic benefits approach was employed to allocate WCF to hydropower generation in multipurpose reservoirs, other approaches for estimating the hydropower WCFs are subjects for future analysis and updates to the GREET® model.

## Addressing Water Consumption and Degradation in LCA – Methodology and Examples

*Laura Scherer, VU University Amsterdam, NL*

Water scarcity adversely affects human health, ecosystems and the economy. It can be described by water scarcity indices which depend on both water availability and consumption. Since it varies spatially and temporally, fine resolutions are required for both dimensions. Building on the indicator developed by Pfister et al. (2009), we calculated monthly water scarcity indices at a resolution of 0.5° for the recent decade 2001-2010. Results show that we are already living under water scarce conditions at the global level.

Energy production follows agriculture in global water use and is also the stage with the largest water use along the life cycle of an electric vehicle. The impacts of electric vehicles largely depend on the electricity source or mix. Hydropower is often promoted as clean, renewable electricity source. It is currently the largest source of renewable electricity and still has a great potential for growth. Considering its importance, we calculated water scarcity footprints of about 1500 hydropower plants in 2009 using a new methodology that takes into account net evapotranspiration from the reservoir, monthly storage changes and allocation between multiple reservoir purposes. Globally, hydropower’s water scarcity footprint is 6.89 m<sup>3</sup> H<sub>2</sub>O<sub>e</sub> / GJ; however, it varies substantially between individual plants. While some plants even alleviate water scarcity (indicated by a negative footprint), others exceed the water consumption of conventional electricity sources by several orders of magnitude. This again highlights the need for a spatially and temporally explicit assessment.

In another study, we compared the water scarcity footprints of fossil fuels and biofuels. While liquid biofuels have a higher water scarcity footprint than fossil fuels, biogas generally performs slightly better in terms of water scarcity than fossil fuels, but impacts differ among the sources for biogas.

Besides water scarcity, water degradation imposes pressure on water resources. Degradation can be physical – such as flow alterations – and chemical – such as freshwater eutrophication and thermal pollution. The impacts of flow alteration were also assessed based on a monthly water balance approach for the same hydropower plants as above. In contrast to water scarcity impacts, impacts by flow alterations cannot be beneficial, as



reduced and increased river discharges can damage ecosystems. The environmental water stress footprint amounts to  $24.5 \text{ m}^3 \text{ H}_2\text{O}_e / \text{GJ}$ , which implies that more damage is caused by flow alterations than water consumption.

Freshwater eutrophication especially results from phosphorus emissions. Taking the example of maize and soya bean production, as relevant biofuel crops, a global spatially explicit model for phosphorus emissions and associated impacts on biodiversity will be demonstrated. Hotspots are around Lake Victoria and along the Russian border to Kazakhstan.

Lastly, a recent study calculated impacts of heat emissions from thermoelectric power plants to rivers at the global level. The Great Lakes and the Danube are among the most thermally impacted watersheds, mainly due to coal and nuclear power plants.

## **LCA of innovative Li-S batteries for electric vehicles**

*Gabriela Benveniste Pérez, Cristina Corchero, IREC, Spain*

Lithium Sulphur Batteries (Li-S batteries) are the most viable candidates for the commercialisation among all posts Li-ion battery technologies due to their high theoretical energy density and cost effectiveness. Despite many efforts, there are remaining issues that need to be solved to boost these batteries technological development. Some of technological aspects, like development of host matrices, interactions of host matrix with polysulphides and interactions between sulphur and electrolyte have been successfully developed in recent and ongoing projects, while now research is focusing on studying the open porosity of the cathode, interactions between host matrices and polysulphides and proper solvation of polysulphides are requirements for the complete utilisation of sulphur. Besides the technological challenges, Li-S batteries need to demonstrate their environmental and economical sustainability, in order to become the preferable alternative to conventional Li-ion ones. For this reason, LCA methodology is applied to study the environmental performance of Li-S cells and battery packs (“cradle to grave” LCA analysis), following ISO 14040-44 standards. This abstract presents the LCA study that is being carried out for the above mentioned Li-S battery cells and packs for electric vehicles. The LCA includes a qualitative assessment of safety aspects with regards to the use of Li-S cells in their intended application, the transport of new and used cells, and the treatment at the end of the battery life. In order to accomplish with current EU-directive 66/2006 that defines a minimum recycling efficiency of 50 wt.% of the battery, an innovative recycling process using novel technology for the vacuum fractionated distillation of battery metals is studied under LCA perspective, whose objectives are focused on achieving high recovery efficiency, at low energy consumption and with a minimized environmental impact. Due to the technology used, this recycling process is deemed to generate metal fractions of high purity at a market-orientated processing cost. This LCA assessment is included in HELIS “High energy lithium sulphur cells and batteries” project. This project receives funding from the European Union’s Horizon 2020 research and innovation programme under Grant Agreement No 666221.



<b>Results of Group work</b>
------------------------------

Discussion on main assumptions and key issues of assessing current and future EV fleets:

1. PHEV in ICE-Mode behaves like a HEV, so the fuel efficiency is 40% higher than ICE in US, in EU less but 10%
2. Diesel&gasoline separation possible?
3. Charging losses are included in electricity consumption of EVs
4. PV self-consumption via storage not included as not relevant for current EV-Fleet
5. Size of generic vehicle (ICE, EV) is middle-size, “Golf class”
6. Electricity consumption EV (US): 20 kWh/100km incl. charging losses
7. Fuel consumption (US): ICE 78 kWh/100km, PHEV 52 kWh/100km
8. Lifetime of vehicles: 10 years
9. Substitution range 85% - 100%
10. PM emissions: zero in cities
11. Total cumulated primary energy demand and its renewable part are indicators for energy efficiency
12. Use these results to Update of estimation in US (ARGONNE) and other countries (JOANNEUM)

## Annex 2: Expert Workshop on Effects on Air

*“There is international consensus that the environmental effects of electric vehicles can only be analyzed on the basis of Life Cycle Assessment (LCA) including the production, operation and the end of life treatment of the vehicles in comparison to conventional vehicles”*



## Emissions to Air in the LCA of Electric Vehicles

-

### Current Status and Future Perspectives

*Documentation of Expert Workshop*

**Time:** September 18&19, 2018

**Place:** Stuttgart, Germany

**Local organisers:**

DLR



Simone Ehrenberger, [Simone.Ehrenberger@dlr.de](mailto:Simone.Ehrenberger@dlr.de)

Gerfried Jungmeier, [gerfried.jungmeier@joanneum.at](mailto:gerfried.jungmeier@joanneum.at)

## Introduction

Electric vehicles have the potential to substitute for conventional vehicles to contribute to the sustainable development of the transportation sector worldwide, for example, in the reduction of greenhouse gas (GHG) and particle emissions. There is international consensus that the improvement of the sustainability of electric vehicles can only be analysed on the basis of life cycle assessment (LCA) (Figure 1), which includes the production, operation, and the end-of-life treatment of the vehicles and the fuel cycle. All environmental impacts must include the whole value chain and - if relevant - interactions from recycling in the dismantling phase to the production phase, if recycled material is used to produce new vehicles.

The Implementing Agreement on “Hybrid and Electric Vehicle (HEV)” of the International Energy Agency (IEA) is operating the Task 30 “Assessment of Environmental Effects of Electric Vehicles” to examine the environmental effects of vehicles with an electric drivetrain based on life cycle analyses. The Task 30 started in 2016 and will continue until the end of 2020. The main activities influencing the environmental impacts of electric vehicles on a life cycle basis are:

- 1) Production and life time of the battery,
- 2) Electricity consumption of the vehicle in the operation phase, incl. e.g. energy demand for heating,
- 3) Source of the electricity, only additional renewable electricity maximizes the environmental benefits and
- 4) End of life treatment of the vehicle and its battery.

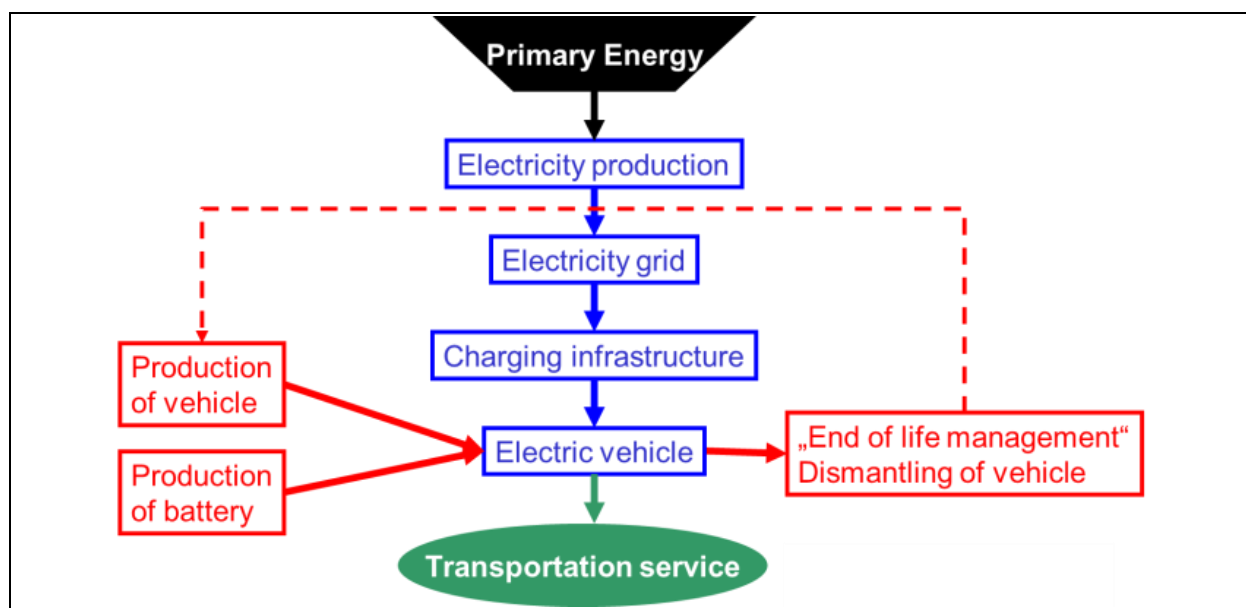

Figure 1: Key elements of the life cycle assessment of vehicles with an electric drive train

## Aims of the workshop

The aim of the expert workshop of Task 30 is to analyse and assess environmental effects of electric vehicles (EVs) on emissions to air based on life cycle assessment in a cooperation of the participating countries in the International Energy Agency (IEA).

The aim of the workshop is to present and discuss the current status and the future perspectives of emission to air in the LCA of Electric Vehicles in comparison to conventional vehicles with an internal combustion engine (ICE). The main focus is on Battery Electric Vehicles (BEV) and Plug in Hybrid Electric Vehicles (PHEV).

The results of the activities of LCA activities in IEA HEV since 2012 will be presented and recent developments in LCA methodology development and its application to EVs. In a group of relevant stakeholder from government, industry, research and NGOs the relevant issues of effects on air emissions will be identified and discussed referring to the ongoing large scale market introduction of EVs.

The main topics for the workshop are:

1. LCA methodology on air emissions
2. Necessary data on air emissions
3. Case studies on air emissions of EVs, ICEs, batteries, electricity and conventional fuel production
4. Identification of “hot spots” on air emissions in process chain of EVs, PHEVs and conventional ICEs
5. NOx and PM emission in LCA and their effects on air quality and health
6. Findings and Recommendations on e.g. methodology, emissions to air.

The format of the workshop is based on presentations, discussion and group work.

## Results of the workshop

The summarized results of the workshop are the following:

- The main air emissions analysed in the inventory (LCI) and assessed (Impact Assessment) are CO<sub>2</sub>, NO<sub>x</sub>, SO<sub>2</sub>, CO, PM and CH<sub>4</sub> & N<sub>2</sub>O.
- The main sources of these air emissions in LCA of EVs and ICEs are
  - ICE-vehicle
  - PHEV-vehicle
  - Thermal power plants providing the electricity for the EVs and
  - Oil refineries to convert raw oil to gasoline and diesel
- These mains sources of air emissions must be documented in the foreground data in the LCA (beside the energy consumption of the vehicles) explicitly to allow better communication and comparison of the LCA results.

- The main impacts directly related to these air emissions are
  - Global warming potential in CO<sub>2</sub>-equivalent (CO<sub>2</sub>, CH<sub>4</sub>, N<sub>2</sub>O)
  - Acidification in SO<sub>2</sub>-equivalent (NO<sub>x</sub>, SO<sub>2</sub>)
  - Ozone formation in C<sub>2</sub>H<sub>4</sub>-equivalent, CH<sub>4</sub>, NO<sub>x</sub>, CO, (NMVOC)
- The Canadian Case Study also assessed Human health (DALY) and Ecosystem Quality (PDF m<sup>2</sup> year).
- The air emission of ICE and PHEV vehicles should be derived from real world driving conditions including user behaviour and climate conditions reflecting the cooling and heating demand in different regions/countries.
- Most LCA studies presented comparing EVs and ICE vehicles mainly analyse and assess greenhouse gas emission and primary energy demand, only few studies also assess other impact categories, e.g. air emissions.
- The emission associated with the production and end of life of the automotive batteries are a very relevant issues, whereas currently the “generally accepted” GHG emission are 175 (150 - 200) kg CO<sub>2</sub>-eq/kWh (ivl 2017, ICCT 2018) and referring to about 35 g CO<sub>2</sub>-eq/km (ICCT 2018).
- Other air emission from battery production where not presented.
- As the development of automotive batteries is very quick and innovate as well as the mass production of automotive battery production is starting these days, no average new data on battery production based on material demand and energy demand for cell and system assembling were presented.
- The end of life (EoL) of automotive batteries might become relevant for the impacts of battery production. Two different EoL strategies are discussed, the materials recycling and the 2nd use in a stationary application. Generally it is not expected that the direct use of the old automotive batteries (< 80% SOC) for stationary application e.g. storage for PV plant) will gain commercial interest. A commercial business case could be to disassemble the cells and use the “best” cells to make a new stationary battery to give adequate warrantee.
- For the LCA of batteries the EoL might have significant influence in the case of 2nd use, as a significant part of the impacts of battery production might be allocated to the automotive and the stationary use, e.g. allocated according to the total electricity throughput in these two applications. The case of material recycling might not affect the total impact of automotive batteries significantly as the increasing amount of battery production volume requires big amounts of primary materials while the

recycling material is still limited to the small number of used automotive batteries available for recycling.

- The general results of the LCAs comparing ICE and EVs show the following
  - If the BEVs use a high share of renewable electricity the impacts on air emissions are significantly lower than from ICE.
  - Beside using renewable electricity the impacts of PHEV strongly depend on the share of electric driven kilometres. In pure electric mode the PHEV has similar impacts than the BEV. In combustion mode the impacts of a PHEV are more or less equal to an ICE or an HEV.
  - If the electricity used for the EVs has a high share of fossil based electricity the impacts of the EVs are similar to the impacts of an ICE.
- Modelling can also be done using dynamic LCA data on electricity production in order to determine CO<sub>2</sub>-eq e.g. per half hour interval due to electricity production. This can help to set policies considering not only the supply and demand of electricity, but also for charging the vehicles when renewables are supplying electricity to the grid.
- Currently the LCA based comparison of EVs and ICE is done for single vehicles, whereas now first application of LCA to whole fleets of vehicles become relevant, e.g. when modelling future scenarios to fulfil PARIS targets. (single vehicle vs. vehicle fleets)
- In applying LCA to vehicle fleets the questions of really substituting ICEs by EVs become more and more relevant. It is observed that the global, national and regional vehicle stocks of ICE are still growing while also the stock of EVs is growing, even much faster than those of ICEs. Additionally it is observed that EVs become also the 2<sup>nd</sup> and 3<sup>rd</sup> vehicle in households. So for LCA used in scenario analyses or for whole fleets of vehicles these developments mean that maybe in reality not each new EV substitutes an ICE even. These effects are called “(direct) rebound effects”.
- For applying LCA to EV fleets compared to ICE fleets a methodological approach must be developed to integrate possible rebound effect in the LCA methodology, e.g. that 1 km driven by an ICE is not 100% substituted by an EV.
- The methodological combination of LCA with scenario analyses will become interesting in future in which a burden shifting from transport sector in the electricity or industry sector becomes relevant and must be shown explicitly. There is also the possibility of using consequential LCA analysis to model this effect.



In the workshop the key issues on “Emissions to Air in the LCA of Electric Vehicles” were identified and discussed. These 6 key issues were grouped the following

1. Manufacturing of vehicle and battery
2. Vehicle operation
3. Electricity for EVs
4. End of life (EoL) of batteries
5. Battery characteristics
6. Data availability and quality

The details collected and discussed on these 6 key issues were

- Manufacturing of vehicle and battery
  - Air emissions of (future) battery production
  - New inventory data on battery production
  - Energy demand of battery production
  - Vehicle manufacturing
  - Impacts of mining the materials
- Vehicle operation
  - Use and document real world energy consumption and emission data for ICE, BEV and PHEV
  - Non GHG gases
    - Function of exhaust gas treatment
    - “non linearity”
    - Dependent on conditions
  - Influence of user
    - Driving profiles
    - Charging behaviours’
    - Thermal comfort
    - Rebound effects
  - Influence of climate (cold weather can decrease battery efficiency, hot weather can cause faster battery degradation)
- Electricity for EVs
  - Reliable air emission data of electricity generation today and in future
  - Air emissions of renewable electricity generation mainly based on material used

- Electricity generation mix and future developments
- Influence of flexible charging (mix versus marginal)
- Regional dynamic grid mix
- Handling of import and export of electricity in region/country
- Include storage for renewable electricity (esp. PV and wind)
- End of life (EoL) of batteries
  - Recycling vs 2<sup>nd</sup> life
  - Assessing 2<sup>nd</sup> use and recycling
  - Estimation on influences of EoL for vehicles and batteries on LCA comparison
- Battery characteristics
  - Energy density of battery
  - Battery life time
- Data availability and quality
  - ICE and PHEV: NO<sub>x</sub>, PM, CxHy
  - Thermal power plants: NO<sub>x</sub>, PM, CxHy, SO<sub>2</sub>; share of heat use in CHP plants
  - Prechain air emissions, e.g. steel, lithium, aluminium, copper
  - Indicators for data quality
  - Data availability: how to close data gaps

In the workshop the following future developments in the LCA of EVs were identified and discussed:

- Air emission of ICE, PHEV, power plants and refineries must be foreground data
- Are there any other relevant air emissions beside NO<sub>x</sub>, SO<sub>x</sub>, CO, PM?
- Find and define reasonable ranges for air emission in LCI and LCA
- Consider regional and seasonal differences of vehicle operation and electricity
- Where is or might be a problem of air emission with EVs? possible solutions
- Parameters to decide on electricity generation for EVs
- Criteria to decide on marginal vs current/future electricity grid mix
- System boundaries w or w/o 2<sup>nd</sup> battery life as energy storage
- Consideration of building new infrastructure (macro level vs functional unit level)  
(Charging infrastructure)
- Criteria to include or exclude impacts from road infrastructure
- Impact assessment of GHG emission with CO<sub>2</sub>-eq or contribution to the future increase/decrease of global temperature

- Systematic description of results showing the shares of emissions of sectors and countries: Burden shifting between countries and between sectors
- Possible rebound effects and influences on LCA results → new functional unit
- Time effects in LCA: changing of electricity mix during lifetime of EV
- Develop LCA methodology to be applied for vehicle fleets and identify differences to “single vehicles”

### PROGRAMM

*Tuesday September 18, 2018*

9:30 Welcome @ DLR

9:45 Introduction - Aims of the Workshop

10:00 – 10:15 IEA HEV Task 30 “**Assessment of Environmental Effects of Electric Vehicles**” (Gerfried Jungmeier, JOANNEUM RESEARCH, A)

#### Key Notes

Chair: N.N.

10:15 – 10:50 **Emissions to Air in the LCA of Electric Vehicles – Recent Findings in the USA** (1) (Amgad Elgowainy, Argonne National Laboratory, USA)

10:50 – 11:15 **Real-world Emissions of Plug-in Hybrid Vehicles** (2) (Simone Ehrenberger, DLR, Germany)

#### Emissions to Air in the LCA of Electric Vehicles

Chair: N.N.

11:15 – 11:40 **Development of the Car Fleet in EU28+2 to Achieve the Paris Agreement Target to Limit Global Warming to 1.5°C**, (3) (Bent van den Adel, DLR, Germany)

11:40 – 12:05 **LCA of Battery Production and Levers for Improvement** (*cancelled*) (Benjamin Reuter, thinkstep, Germany)

12:05 – 12:30 Discussion

#### LUNCH

13:30 – 13:50 **LCA Guidelines for Electric Vehicles** (4) (Patrik Klintbom, RISE Viktoria, Sweden)

13:50 – 14:10 **ICE versus the Electric Vehicle - LCI Deviations when Updating Inventories Towards Real-World Oriented Emissions** (5) (Eckard Helmers, University of Applied Sciences Trier, Germany)

14:10 – 14:30 **Regional Comparison of Life-cycle CO<sub>2</sub> Emissions from Gasoline and Plug-in Electric Vehicles in the United States** (6) (Tugce Yuksel, Sabanci University, Turkey)

14:30 – 15:00 Discussion

#### BREAK

15:30 – 17:00 **Group work** on identification of key issues on “Emissions to Air in the LCA of Electric Vehicles”

17:00 – 17:30 Presentation and **discussion** of group work

*18:30 DINNER @ Brauhaus am Schlossplatz*



## PROGRAMM

*Wednesday September 19, 2018*

### Country update on LCA of EVs

Chair: N.N.

9:30 – 9:50 **Spain** (7) (Deidre Wolff, IREC, Spain)

9:50 – 10:10 **Austria** (8) (Gerfried Jungmeier, JOANNEUM RESEARCH, Austria)

10:10 – 10:30 **Republic of Korea** (9) (Ock Taeck Lim, University of Ulsan, Republic of Korea) *remotely*

10:30 – 10:50 **Germany** (10) (Simone Ehrenberger, DLR, Germany)

10:50 – 11:10 **Canada** (11) (Pierre-Olivier Roy, CIRAIG, Canada) *remotely*

11:10 – 11:30 **Estimated Environmental Impacts of Global EV-Fleet in 33 Countries - Facts & Figures from the IEA Technology Collaboration Program on Hybrid & Electric Vehicles** (12) (Gerfried Jungmeier, JOANNEUM RESEARCH, A)

11:30 – 12:00 Discussion

#### *LUNCH and DLR TOUR*

13:30 – 15:00 **Group work** on future developments in LCA of EVs

15:00 – 15:30 Presentation and discussion of group work

15:30 – 16:00 **Summary**, conclusions and next steps

END of WORKSHOP

16:00 – 17:30 Task 30 business meeting (members only)

*18:30 Task 30 DINNER*

## ABSTRACTS

### **Li-S batteries for electric vehicles, preliminary LCA and challenges for circular economy objectives**

Gabriela Benveniste\*<sup>1</sup>, Deidre Wolff\*<sup>1</sup>

<sup>1</sup> Catalonia Institute for Energy Research, Jardins de les Dones de Negre 1, 08930 Sant Adrià del Besòs, Barcelona, Spain;

The continuous and planned increase of the electrification in the transport sector is one of the main drivers of advances in energy storage for electric vehicle (EV) propulsion and present technological challenges to achieve the expected requirements. The implementation of the EVs on our roads remains a challenge and is below expectations foreseen. The elevated costs of the batteries and thus the EV cost, refrain the massive depletion of this technology. With the aim of reaching a field of 500 kilometers autonomy in the short term, it is necessary to investigate new materials and configurations of EV batteries. To this end, lithium-sulfur (Li-S) batteries are the closest battery technology capable of meeting these expectations. Although Li-S can overcome the technical issues, this solution still needs to demonstrate how the socio-economic-environmental barriers associated are solved, above all when considering their fitting in a circular economy society. There are no clear evidences of the environmental benefits due to the use of Li-S batteries as an alternative to Li-ion batteries. Moreover, there it is still unclear of how these batteries should be treated at their end of life with the aim of recovering the maximum amount of valuable materials.

This work focuses on the preliminary LCA results for Li-S coin cells and the methodological design on analyzing the environmental and social aspects related to Li-S batteries using LCA perspective in a circular economy context.

These objectives present a considerable number of challenges due to the lack of data in the Li-S data inventory collection, the uncertainties due to the feasibility of using them in second life and the lack of examples to analyze economic and environmental benefits of designing a customized recycling process. For this reason, the aspects covered by this study are extremely relevant in the frame of considering Li-S batteries technology as a suitable system within the objectives of a circular economy.

This research is being carried out within HELIS Project. This project receives funding from the European Union’s Horizon 2020 research and innovation program under Grant Agreement No 666221.

## Comparing Electric and Conventional vehicles in Quebec, Canada

Pierre-Olivier Roy, CIRAIG, Canada

On October 9th 2015, the Quebec government (Canada) unveiled its *Transportation electrification action plan 2015-2020* which promotes the use of electric vehicles. This plan wishes to increase the number of electric vehicles in Quebec to 100 000. However, the question “*Should an electric vehicle be promoted comparatively to its conventional counterpart in Québec, Canada, considering their potential environmental issues?*” has never been properly addressed. While several LCA studies were made in recent years, these were mostly made for the European or the American context; relying on parameters representative of these contexts which are not representative of Quebec or alternatively Canada. Indeed, the province of Québec has several distinguishing characteristics: 1) an electrical grid mix mostly based on hydroelectricity, 2) a lack of fossil fuel production or 3) vehicles production facilities, 4) variable driving patterns, 5) varying driving behavior and 6) extremely (-40°C to 40°C) variable yearly climatic conditions which affect the energy efficiency of the vehicles. The objective is thus to compare the environmental impacts related to a conventional and a 100 % electric vehicle over their entire life cycle and used in Quebec and alternatively in other Canadian jurisdictions. This assessment doesn’t wish to compare specific brands or models but aims to compare the environmental impacts of electric and conventional models that could be found in Québec.

Obtained results for the electric vehicles highlighted the importance of the production of the vehicle electric motor and battery. In comparison, use of the electric vehicle in Quebec, using its electric grid mix, was shown to be a small contributor ( $\approx 5\%$ ) to the environmental indicators. Results for the conventional vehicles showed the importance of the GHG emissions of the conventional vehicle use phase to *global warming* and its implication towards *Human health* and *Ecosystem quality*. Results also showed that the electric vehicle in Quebec is mostly independent of the driving scenarios while the conventional vehicle showed higher variability with increasing lifetime over different scenarios. Results also show environmental benefits, in Quebec, for electric vehicle for the *Human health*, *Ecosystem quality*, *global warming*, and *fossil fuel depletion* indicators over all possible scenarios of the conventional vehicle if the lifetimes of the vehicles are over 100 000 km. However, for a shorter lifetime, some of the driving scenarios of the conventional vehicle could be preferable. The *mineral resource depletion* indicator which will not favor the electric vehicle during its lifetime in its current configuration. Our study also showed that in Québec the efficiency of the charging station (80 to 100 %), the plant production location (Japan or the United States), the type of electric battery (LiNCM over LiFePO<sub>4</sub>) or the electric vehicle battery end of life had little to no consequences on the study conclusions.

Future work wishes to focus on the integration of the electric vehicle in the more complete picture of sustainable mobility and more importantly its consequences when introduced in larger numbers.



## Regional comparison of life-cycle CO<sub>2</sub> emissions from gasoline and plug-in electric vehicles in the United States

Tugce Yuksel, Sabanci University, Turkey

This talk will focus on understanding the effects of regional grid mix, driving patterns and climate on the comparative life cycle CO<sub>2</sub> emissions from gasoline and plug-in electric vehicles (PEVs) across United States. Methodology and results from Yuksel et al., 2016<sup>1</sup> will be presented. We use a data-based simulation model to estimate and compare emissions from conventional vehicles (CVs), hybrid electric vehicles (HEVs), plug-in hybrid electric vehicles (PHEVs) and battery electric vehicles (BEVs). Our results indicate that EVs can have larger or smaller carbon footprints than gasoline vehicles, depending on these regional factors and the specific vehicle models being compared. The Nissan Leaf battery electric vehicle has a smaller carbon footprint than the most efficient gasoline vehicle (the Toyota Prius) in the urban counties of California, Texas and Florida, whereas the Prius has a smaller carbon footprint in the Midwest and the South. Regional variations in grid mix, driving style and ambient temperature, as well as vehicle model can all affect this comparison. During the talk, the policy implications, as well as potential changes with the advancements in PEV technology and grid mix will be discussed.

<sup>1</sup> Yuksel, T., Tamayao M.M., Hendrickson C., Azevedo I., & Michalek J.J. (2016). *Variation of Electric Vehicle Life Cycle Greenhouse Gas Reduction Potential across U.S. Counties due to Regional Electricity Sources, Driving Patterns, and Climate*, Environmental Research Letters, DOI: 10.1

## **Task 30 “Assessment of Environmental Effects of Electric Vehicles”**

**Members:** Austria, Canada, Germany, Spain, South Korea, Turkey, USA

Electric vehicles have the potential to substitute for conventional vehicles to contribute to the sustainable development of the transportation sector worldwide, for example, in the reduction of greenhouse gas (GHG) and particle emissions. There is international consensus that the improvement of the sustainability of electric vehicles can only be analyzed on the basis of life cycle assessment (LCA), which includes the production, operation, and the end-of-life treatment of the vehicles and the fuel cycle. All environmental impacts must include the whole value chain and - if relevant - interactions from recycling in the dismantling phase to the production phase, if recycled material is used to produce new vehicles.

The aim of Task 30 (2016 – 2020) is to analyze and assess environmental effects of electric vehicles (EVs) on water, land use, resources and air based on life cycle assessment in a cooperation of the participating countries in the International Energy Agency (IEA).

Task 30 is using the results of the completed Task 19 “Life Cycle Assessment of Electric Vehicles” (2011 – 2015, [www.ieahev.org/tasks/task-19-life-cycle-assessment-of-evs/](http://www.ieahev.org/tasks/task-19-life-cycle-assessment-of-evs/), led by JOANNEUM RESEARCH) as a foundation to subsequently examine the environmental effects – benefits and impacts - of vehicles with an electric drivetrain (EVs), based on life cycle assessment (LCA). With an eye on the three phases of LCA, such as production, operation and dismantling of EVs, various environmental effects of EVs on water, land use, resources and air, among others, will be analyzed and assessed. Thereby a strong accent is put on the comparison of environmental effects between pure battery EVs (BEV) and Plug-in hybrids (PHEVs) on one hand and conventional ICE vehicles using gasoline and diesel on the other side.

In recent years the focus in environmental assessments of electric vehicles was on global warming and primary energy consumption. But now it is recognized that other impacts gain additional relevance and must be addressed by life cycle based comparisons like water, land use, resource consumption, local PM and NO<sub>x</sub>-emissions. Therefore Task 30 will focus on following topics covering methodologies, data and case studies:

- Effects of EVs on water (emissions to water, waste water, “Water Footprint” of EVs)
- Effects on EVs on land use-resources-waste (land use, occupation and degradation, demand of renewable and fossil resources, recycling)
- Effects on EVs on air (local emissions and effects of NO<sub>x</sub>, PM and C<sub>x</sub>H<sub>y</sub>, human health effect and non-energy related emissions from tires and brakes)
- Overall environmental effects and their assessment (comparing and assessing different impact categories, single score methodologies, stakeholder involvement).

Within the Task, methodologies for helping countries implement EVs by identifying possibilities to maximize the environmental benefits will be developed. Besides, various case studies will be analyzed and networking combined with information exchange will be

supported within the Task’s frames (Figure 1). The Task will proceed by holding a series of expert workshops addressing the following objectives:

- Methodologies on assessment of environmental effects
- Analyses of necessary and available data
- Overview of international studies/literature
- Analyses of current knowledge and future challenges
- Overview of key actors and stakeholders and their involvement
- Communication strategies to stakeholders
- Summarizing further R&D demand

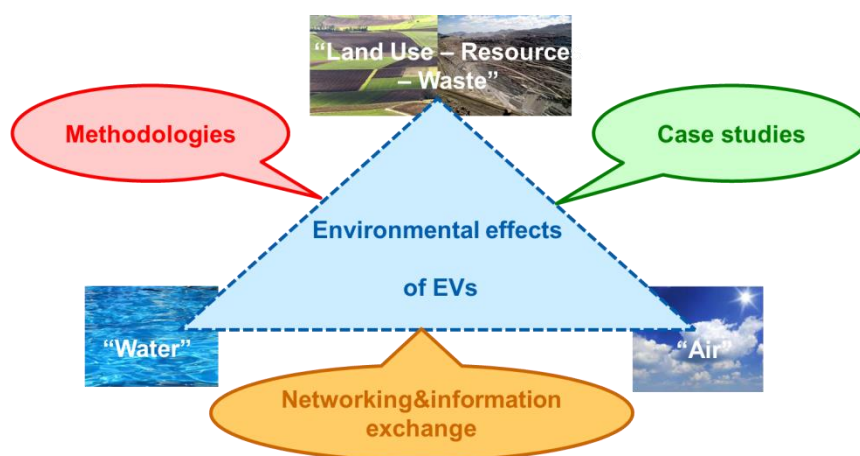

Figure 1: Working method in Task 30

Members in this Task will compile a list of environmental benefits and impacts of EVs with the goal to increase their overall acceptance by providing facts and figures on the environmental effects of EVs. Thus, numerous advantages of EVs compared to conventional vehicles will be shown. These results should help the industry and government to support further development and employment of EVs in all transport modes. The results will document and summarize the state of current knowledge and future challenges (incl. methodologies and case studies) on

- Effects of electric vehicles on water
- Effects of electric vehicles on Land use – resources – waste
- Effects of electric vehicles on air
- Overall environmental effects and their assessment of EVs
- R&D demand.

In addition to these technical and scientific results a glossary on “Frequently asked questions” (FAQ), a framework for Communication strategies to stakeholders and dissemination activities (e.g. proceedings, reports, papers, notes, presentations) will be available.

## Contact Details of the Operating Agents

For further information, please contact the Task 30 Operating Agent:

### Dr. Gerfried Jungmeier

JOANNEUM RESEARCH Forschungsgesellschaft mbH

LIFE – Centre for Climate, Energy and Society

Waagner-Biro-Strasse 100

A-8020 Graz, Austria

[gerfried.jungmeier@joanneum.at](mailto:gerfried.jungmeier@joanneum.at)

+43 316 876 1313

The Work of JOANNEUM RESEARCH is financed by Austrian klima + energie fonds



### Dr. Gabriela Benveniste

IREC – Catalonia Institute for Energy Research

Jardins de les Dones de Negre, 1 2ªPI

Sant Adrià de Besòs 08930

[gbenveniste@irec.cat](mailto:gbenveniste@irec.cat)

+34 933 562 615

[www.ieahev.org/tasks/task-30-assessment-of-environmental-effects-of-electric-vehicles/](http://www.ieahev.org/tasks/task-30-assessment-of-environmental-effects-of-electric-vehicles/)

**Annex 3: Expert Workshop on Resources, Waste and Land Use  
(incl. LCA Autonomous Vehicles)**



**Effects of EVs on  
Land Use – Resources – Waste**  
incl. special topic: LCA of Autonomous Vehicles  
*Expert Workshop*

**June 13 – 14, 2019  
Washington D.C., USA**



**Local organisers:**





## Content

1	Introduction .....	4
2	Aims of the workshop .....	5
3	Programm .....	6
3.1	Overview .....	6
3.2	Effects of EVs on Land Use – Resources – Waste.....	6
3.3	LCA of Autonomous Vehicles .....	6
3.4	LCA Case Studies.....	7
3.5	Group work on key Issues .....	7
4	Results .....	7
4.1	LCA Battery Production .....	7
4.1.1	Current LCA developments .....	7
4.1.2	Cobald and cathode.....	8
4.1.3	Aluminium .....	10
4.1.4	Cell production.....	13
4.1.5	LCA of battery in GREET.....	14
4.2	LCA Battery Recycling.....	14
4.2.1	LCA relevant aspects of battery recycling .....	14
4.2.2	Three German projects on Battery Recycling.....	18
4.2.3	EV Trends for Tomorrow’s Material Resources and Life Cycle Emissions.....	21
4.3	LCA of electric motor recycling (magnets) .....	25
4.4	LCA of power electronics recycling .....	28
4.5	Land use .....	30
4.6	LCA of autonomous vehicles .....	34
4.6.1	Introduction .....	34
4.6.2	Additional equipment .....	35
4.6.3	Influence on energy demand .....	38
4.6.4	Possible effects on LCA.....	40
4.6.5	Case Study on LCA of autonomous vehicles .....	41
4.7	LCA Case Studies.....	45
4.7.1	PHEV real world measuring.....	45
4.7.2	LCA of Battery and hydrogen fuel cell buses.....	47
4.8	Identification of key issues .....	48
4.8.1	Land Use – Resources – Waste in LCA of EVs.....	49
4.8.2	LCA of Autonomous Vehicles .....	52



5 Information on Task 30 “Assessment of Environmental Effects of Electric Vehicles” .....55

### 1 Introduction

Electric vehicles have the potential to substitute for conventional vehicles to contribute to the sustainable development of the transportation sector worldwide, for example, in the reduction of greenhouse gas (GHG) and particulate emissions. There is international consensus that the improvement of the sustainability of electric vehicles can only be analysed on the basis of life cycle assessment (LCA) ([Figure 1](#)), which includes the production, operation, and the end-of-life treatment of the vehicles and the fuel cycle. All environmental impacts must include the whole value chain, and - if relevant - interactions from recycling in the dismantling phase to the production phase, if recycled material is used to produce new vehicles.

The Implementing Agreement on “Hybrid and Electric Vehicle (HEV)” of the International Energy Agency (IEA) is operating the Task 30 “Assessment of Environmental Effects of Electric Vehicles” to examine the environmental effects of vehicles with an electric drivetrain based on life cycle analyses. The Task 30 started in 2016 and will continue until the end of 2020. The main activities influencing the environmental impacts of electric vehicles on a life cycle basis are:

- 1) Production and life time of the battery,
- 2) Electricity consumption of the vehicle in the operation phase, incl. e.g. energy demand for heating,
- 3) Source of the electricity, only additional renewable electricity maximizes the environmental benefits and
- 4) End of life treatment of the vehicle and its battery.

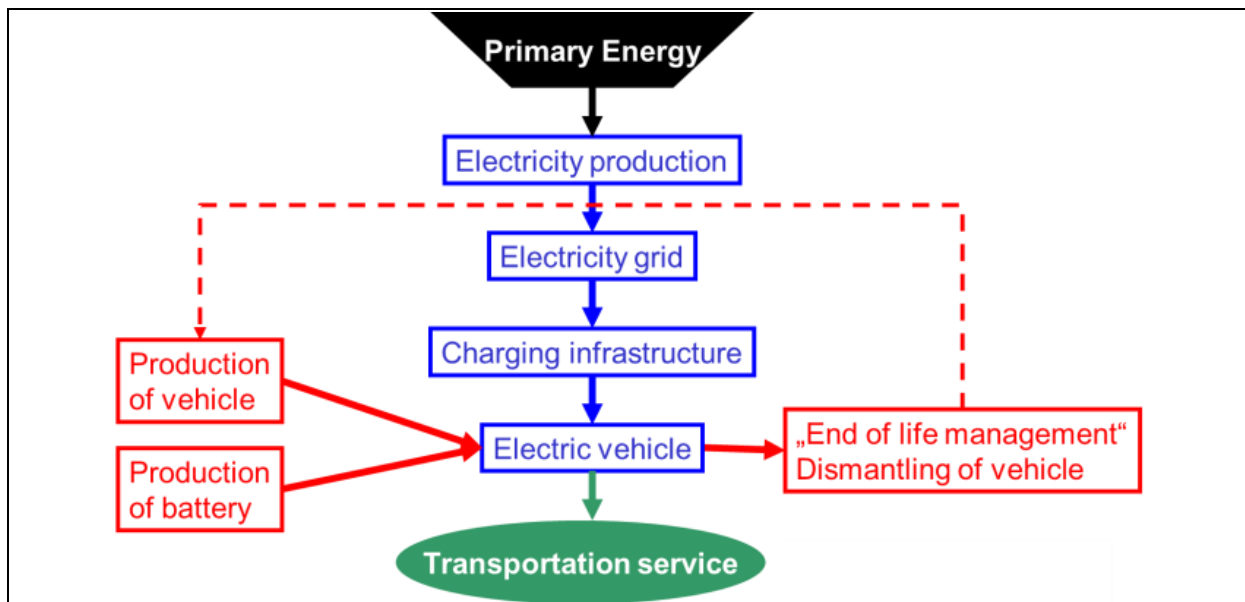

Figure 1: Key elements of the life cycle assessment of vehicles with an electric drive train

## 2 Aims of the workshop

The aim of the expert workshop of Task 30 is to analyse and assess environmental effects of electric vehicles (EVs) on land use, resources, waste based and autonomous vehicles on life cycle assessment in a cooperation of the participating countries in the International Energy Agency (IEA).

The aim of the workshop is to present and discuss the current status and the future perspectives of LCA of Electric Vehicles on these issues in comparison to conventional vehicles with an internal combustion engine (ICE). The main focus is on Battery Electric Vehicles (BEV) and Plug in Hybrid Electric Vehicles (PHEV).

The results of the activities of LCA activities in IEA HEV since 2012, and recent developments in LCA methodology development and its application to EVs will be presented. In a group of relevant stakeholder from government, industry, research and NGOs, the relevant issues of effects on land use, resources, waste and autonomous vehicles will be identified and discussed referring to the ongoing large scale market introduction of EVs and the rapid development of autonomous vehicles.

The main topics for the workshop are:

1. LCA methodology on land use, resources, waste and autonomous vehicles
2. Necessary inventory data
3. Case studies of EVs, ICEs, batteries, electricity and conventional fuel production
4. Identification of “hot spots”
5. Findings and Recommendations

The format of the workshop is based on presentations, discussion and group work.

### 3 Programm

#### 3.1 Overview

The program is divided in the following 4 sessions:

- Effects of EVs on Land Use – Resources – Waste
- LCA of Autonomous Vehicles
- LCA Case Studies and
- Group work on key Issues

#### 3.2 Effects of EVs on Land Use – Resources – Waste

- **Lifecycle Assessment of Resource Use and Recycling Processes for Electro-Mobility**, Cornelia Merz, Öko-Institut e.V., Germany
- **The Future of EVs - What Today’s Trends Mean for Tomorrow’s Material Resources and Life Cycle Emissions**, Alissa Kendall, University of California, Davis, USA
- **Raw Material Supply for Battery and Fuel Cell Technologies - Resource Availability, Production, Recycling and CO<sub>2</sub>-emissions**, Christoph Koffler, thinkstep AG, Germany/USA
- **LCA of Automotive Batteries**, Linda Gaines, Argonne National Laboratory, USA
- **Resource, Land Use and Waste in LCA of Aluminium**, Marshall Jinlong Wang, The Aluminum Association, USA
- **Land Use Assessment in LCA using LANCA®**, Ulrike Bos, Christoph Koffler, thinkstep AG, Germany

#### 3.3 LCA of Autonomous Vehicles

- **Life Cycle Analysis of Automated Vehicle**, Jarod C. Kelly, Argonne National Laboratory, USA
- **Assessing the Impact of Automated Driving - An Initial Step in Evaluating Autonomous Vehicles (AV) Sustainability**, Robb De Kleine, Ford Motor Company, USA
- **Automatization and Energy Consumption – What Does it Mean for LCA of Future Vehicles?**, Simone Ehrenberger, DLR, Germany

### 3.4 LCA Case Studies

- **Real-World Energy and Fuel Consumption from Plug-In Hybrid Electric Vehicles**, Aaron Loisel-Lapointe, Environment and Climate Change Canada, Canada
- **LCA of Battery Electric Buses and Comparison to Diesel and Fuel Cell Buses – What is the Functional Unit**, Gerfried Jungmeier, JOANNEUM RESEARCH, Austria

### 3.5 Group work on key Issues

Identification of key issues on

1. Land Use – Resources – Waste in LCA of EVs
2. LCA of Autonomous Vehicles

## 4 Results

The results are structured in the following topics:

- 1) LCA Battery Production
- 2) LCA Battery Recycling
- 3) LCA of electric motor recycling (magnets)
- 4) LCA of power electronics recycling
- 5) Land use
- 6) LCA of autonomous vehicles
- 7) LCA Case Studies
- 8) Identification of key issues

### 4.1 LCA Battery Production

#### 4.1.1 Current LCA developments

The following key battery materials are updated for LCA in GREET

- a. Cobalt: Co/Ni/Cu prices; shares of Co coproduced with Ni/Cu; shares of sulphide/laterite; ore grade
- b. Nickel: Ni/Cu prices; shares of sulphide/laterite; ore grades; SOx emissions control
- c. Lithium: shares of lithium produced from brine/minerals
- d. Graphite: shares of natural/synthetic graphite

The most relevant energy and emissions of an NMC111 LIB under baseline conditions are

- NMC111 Cathode: Cobalt (sulfate production); Nickel (refining); other cathode steps (NMC11 precursor & powder production)
- Aluminium: Alumina reduction & SF<sub>4</sub>/S<sub>2</sub>F<sub>6</sub> abatement
- Battery management system (BMS): electricity source
- Cell assembly: heat and electricity source

#### 4.1.2 Cobalt and cathode

The cathode powder production is energy intensive, so LCO, NCA and NMC production pathways were updated in GREET based on primary data from a global top 5 producer in China. The cobalt sulfate production is relevant, as it is a precursor to the NMC111 cathode material. Cobalt is largely mined in the Democratic Republic of Congo. CoSO<sub>4</sub> production is very energy intensive and largely occurs in China.

In [Table 1](#) the annual production of Cobalt is shown and in [Figure 2](#) the application of cobalt for different products. In [Figure 3](#) the primary energy demand (PED) and GHG emissions of Cobalt are shown. It is concluded that

- PED and GHG emissions are about a factor 10 higher than for LiCO<sub>3</sub>
- Production steps from ore to metal are rather electricity intensive
- GHG savings potential of 30 - 60% if electricity would be produced using strictly renewable energy

Table 1: Annual production of Cobalt (Koffler 2019)

Country	Annual production [t]	Share (%)	Source
DR Congo	84,401	59%	Sulphide deposits (sedimentary)
China	10,093	7%	Sulphide deposits
Canada	6,904	5%	Sulphide deposits (magmatic)
Australia	6,777	5%	Sulphide deposits (magmatic)

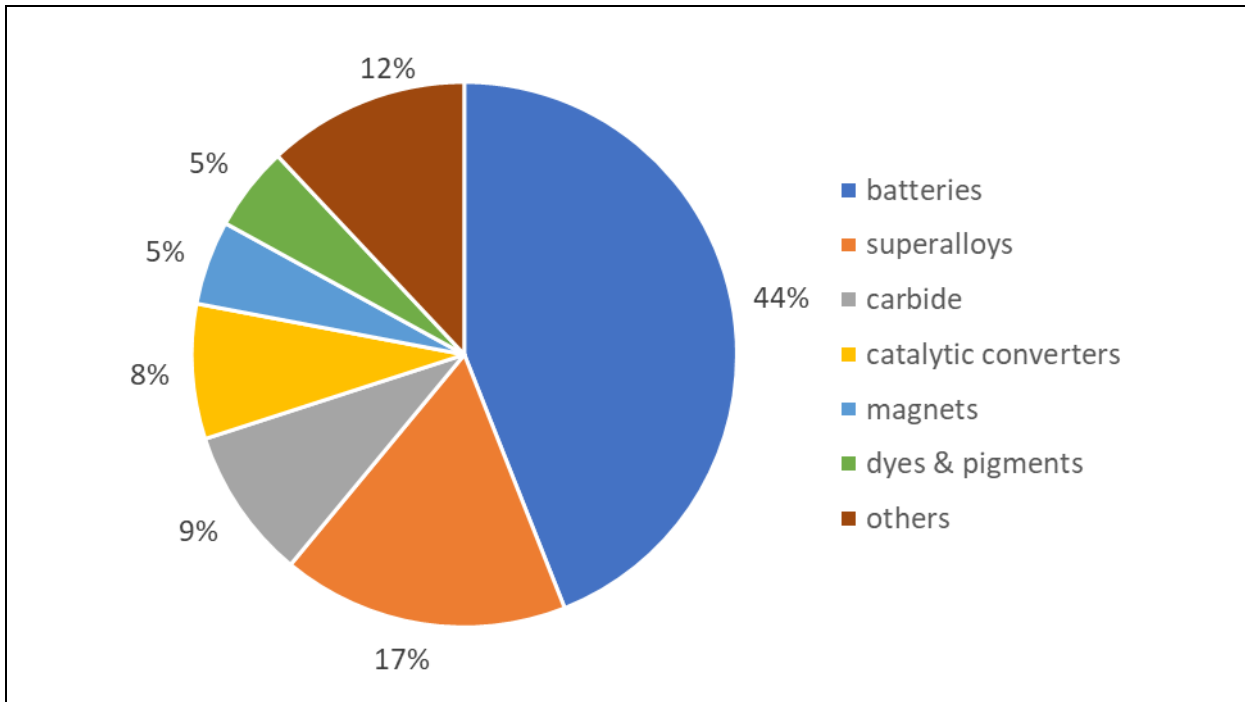

Figure 2: Application of cobalt for different products (Koffler 2019)

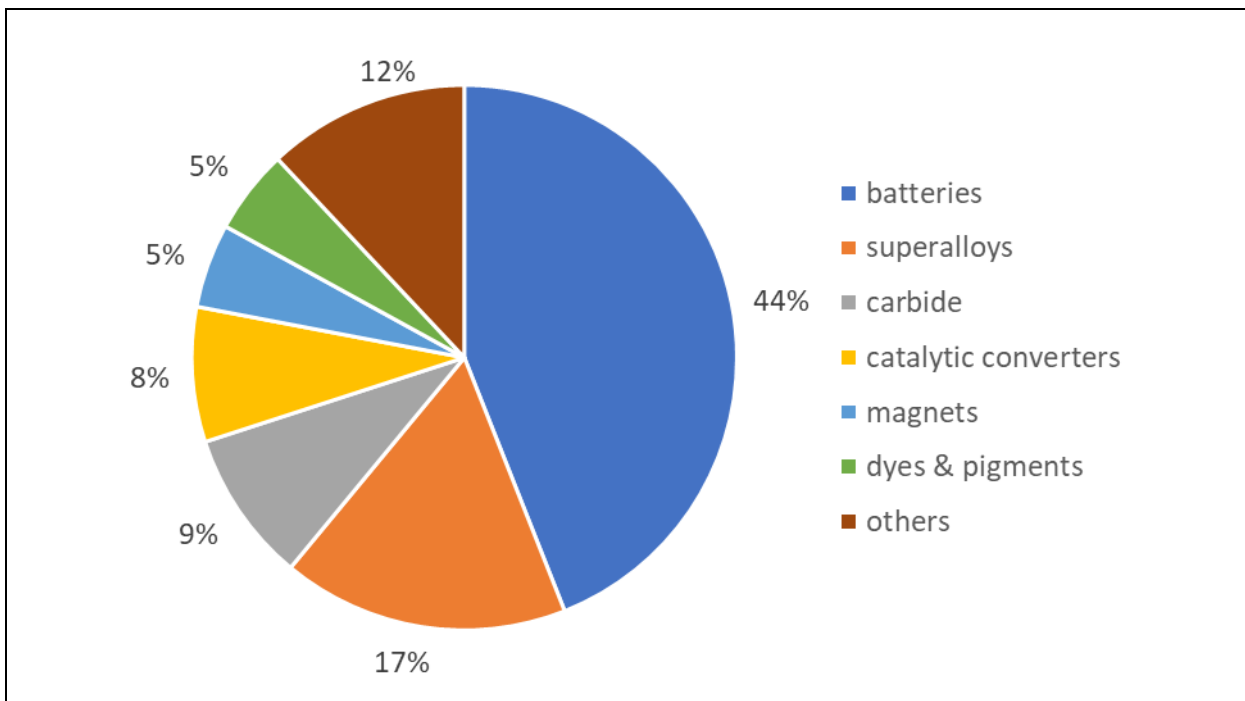

Figure 3: Primary energy demand and GHG emissions of Cobalt (Koffler 2019)

In Figure 4 the cradle-to-gate environmental impacts of 1 kg NMC111 powder are shown, where Nickel/Cobalt precursors and process energy are notable drivers.



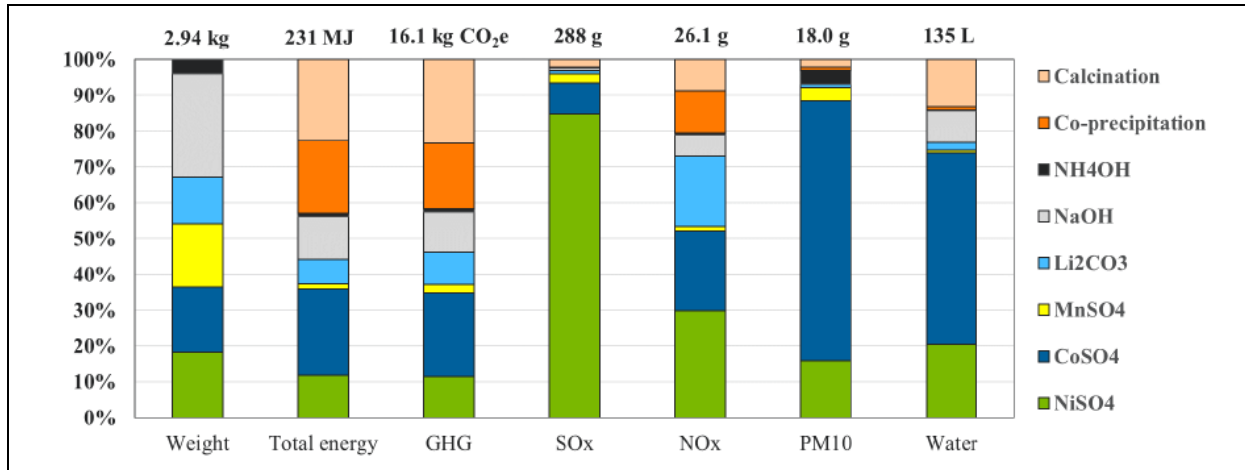

Figure 4: Cradle-to-gate environmental impacts of 1 kg NMC111 powder (Gaines 2019)

### 4.1.3 Aluminium

An NMC111 LIB is about 25% wrought by Aluminium weight. The Aluminium reduction is a major driver for aluminium’s environmental burden, for which mainly electricity is used. So the source of the electricity for aluminium reduction is a key factor for the environmental effects; e.g. China dominates the worldwide aluminium production with about 55%. Additionally during smelting CF<sub>4</sub> and C<sub>2</sub>F<sub>6</sub> can be released which are very powerful GHG emissions.

The aluminium industry works on reducing their life cycle impacts (Figure 5). Most aluminium products are aluminium alloys. Most aluminium products contain both primary and recycled metal.

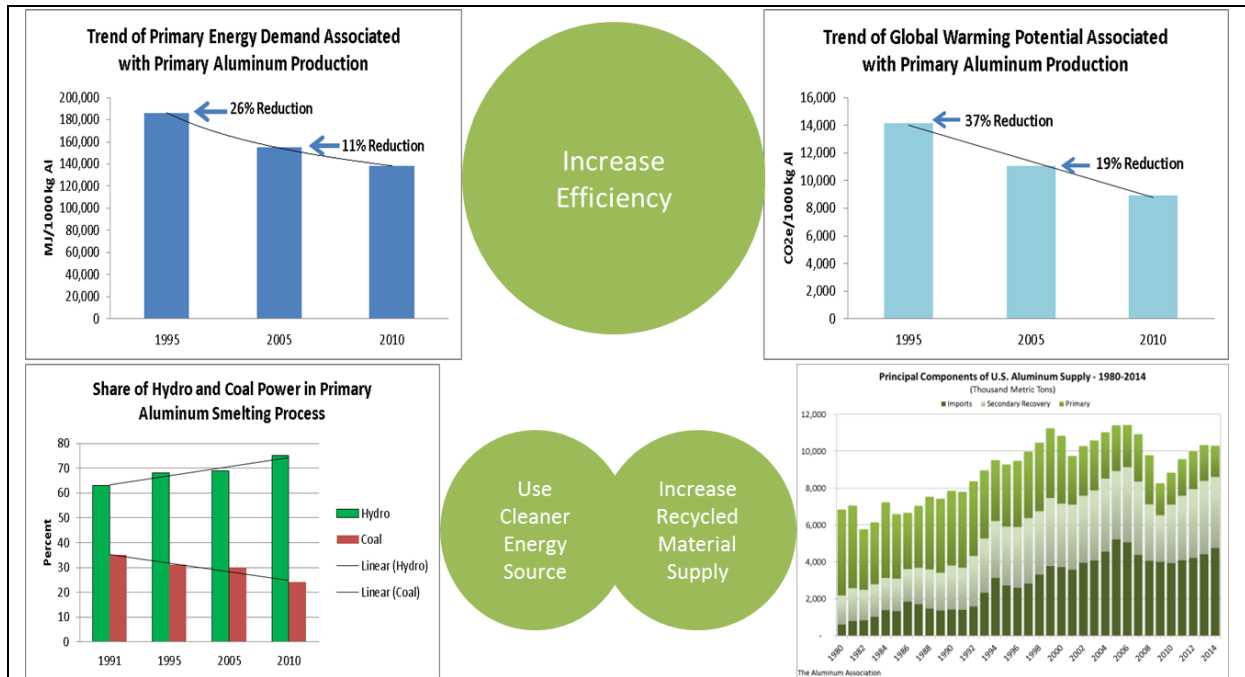

Figure 5: Reducing life cycle footprint is the goal of the aluminum industry (Wang 2019)

In Figure 6 the inventory hot spots of GHG emissions of primary aluminium production are shown. In Figure 7 the GHG emissions of primary and recycled aluminium are given. The most relevant influences are

1. Primary Al sourcing
2. Electricity/source of fuel
3. Share of primary and recycled metals

Depending where the aluminium is produced the environmental impacts are quite different, as shown in

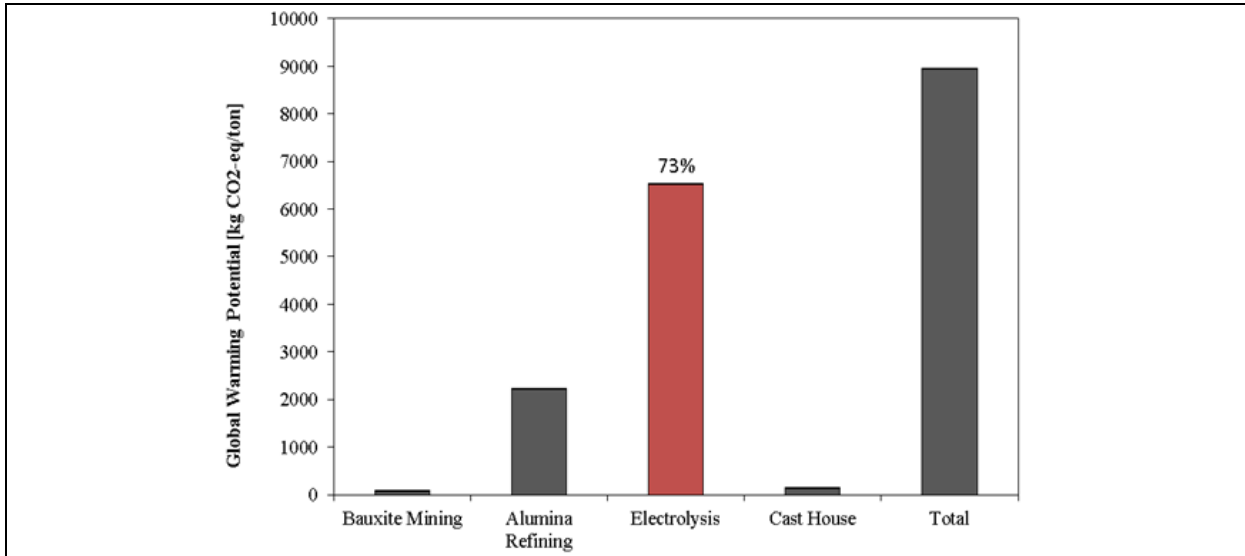

Figure 6: Inventory hot spots of primary aluminum production (Wang 2019)

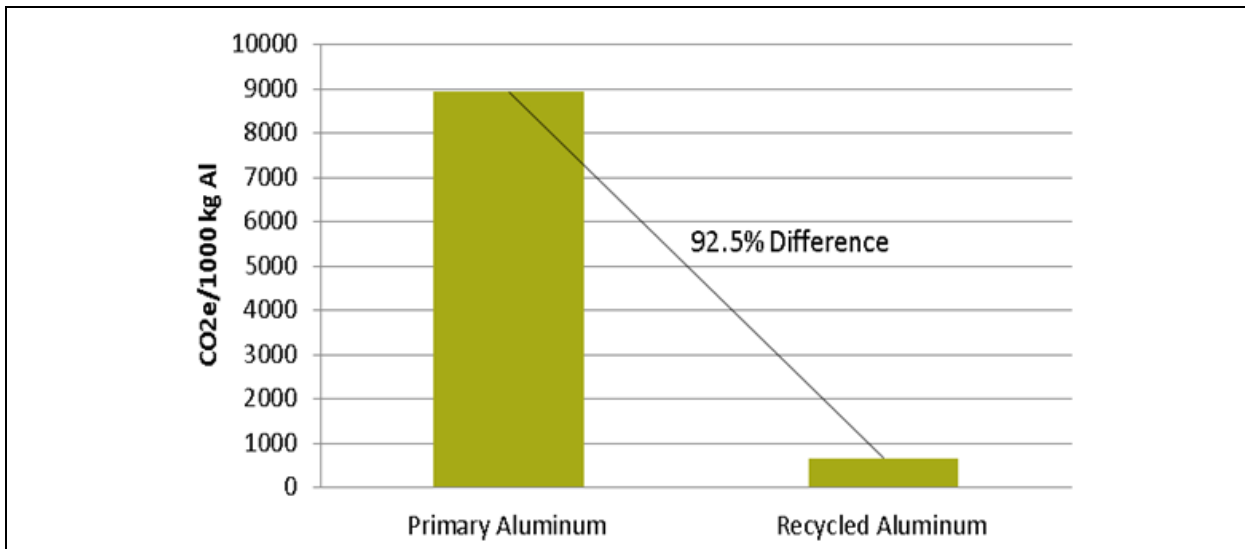

Figure 7: GHG emissions of primary and recycled aluminum (Wang 2019)

**Table 2:** Global and regional primary AI production data (Wang 2019)

	Global	Scenario 1	Scenario 2	Scenario 3	Scenario 4	Scenario 5
<b>Bauxite → Alumina → Aluminium</b>	GLO	CNA→CNA→C NA	OCA→OCA→C NA	SAM→EUR→E UR	OCA→OCA→G CC	SAM→NAM→ CAN
Acidification Potential (AP) [kg SO <sub>2</sub> -Equiv.]	100	110	100	30	50	10
Depletion of fossil energy (DFE) [MJ]	166,000	186,000	180,000	94,000	183,000	50,000
Eutrophication Potential (EP) [kg Phosphate-Equiv.]	7	6	6	3	5	1
Global Warming Potential (GWP 100 years) [tonne CO <sub>2</sub> -Equiv.]	18	20	19	7	15	5
Ozone Layer Depletion Potential (ODP) [kg R11-Equiv.]	1.1E-8	3.1E-9	2.8E-9	1.5E-8	2.3 E-9	3.6E-9
Photochemical Ozone Creation Potential (POCP) [kg Ethene-Equiv.]	7	8	7	2	4	2
Water Scarcity Footprint (WSFP) [m <sup>3</sup> Water-Equiv.]	17	25	25	8	2	4

#### 4.1.4 Cell production

The cell production is a significant energy consumer, which does not scale linearly with production. The cell production consists of

- electrode production,
- cell stacking,
- current collector welding,
- cell encasement,
- electrolyte filling and
- cell closure.

All these steps occur in dry room (moisture content of the air < 100 ppmv) to prevent the electrolyte salt LiPF<sub>6</sub> from reacting with water. The dry room must be run continuously so the energy consumption is the same regardless of the total production within the dry room. A higher throughput leads to lower energy consumption per unit of battery, mainly people in the dry room add to energy load.

The energy demand for battery production and assembly were updated (170 MJ/kWh) based on primary data for a 2 GWh/a production line operating at 75% capacity. The dry room operation and electrode drying are the most energy intensive processes.

#### 4.1.5 LCA of battery in GREET

In [Figure 8](#) the cradle-to-gate environmental impacts of 1 kWh NMC111 battery are shown, where cathode, production energy and aluminium are notable contributors.

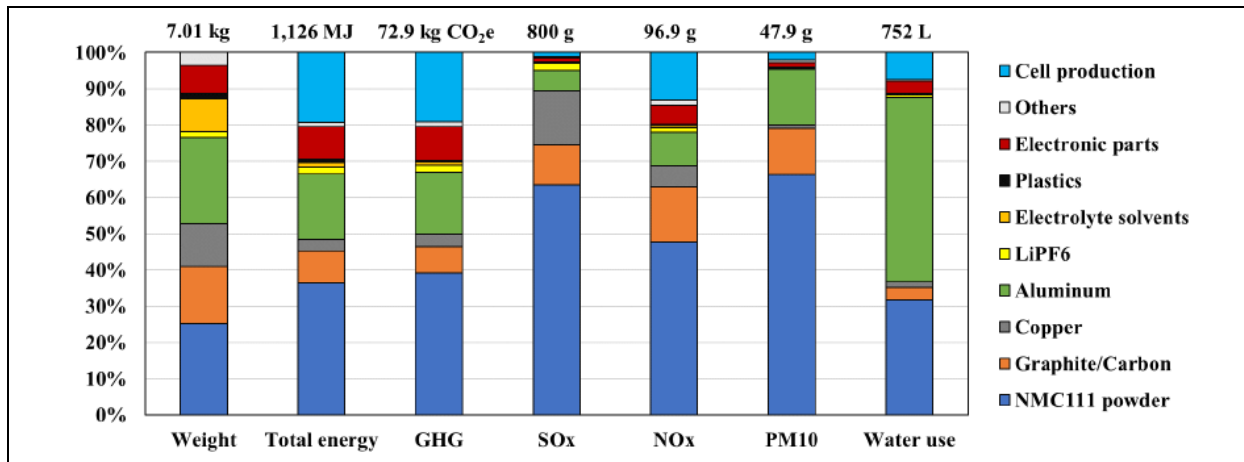

Figure 8: Cradle-to-gate environmental impacts of 1 kWh NMC111 battery (Gaines 2019)

## 4.2 LCA Battery Recycling

### 4.2.1 LCA relevant aspects of battery recycling

There are three main processes for recycling of batteries:

1. pyro process for recycling of batteries ([Figure 9](#))
2. hydro process for recycling of batteries ([Figure 10](#))
3. direct recycling of batteries ([Figure 11](#))

The main relevant aspects for LCA of battery recycling are (based on Gaines 2019)

1. pyro process (smelting) for recycling of batteries:
  - a. process is commercially viable
  - b. flexible process input
  - c. no sorting or size reduction necessary
  - d. Not useful for LFP
  - e. Co, Cu and Ni are recovered
  - f. Li and Al go to slag (Li is recovered if price high enough)
  - g. Additional processes need to separate metals
  - h. SOx emission are avoided
  - i. High temperature process

- j. Organics burnt
  - k. Extensive gas treatment
2. hydro process (hydrometallurgy) for recycling of batteries
    - a. large-scale commercial operation in China and Korea
    - b. size reduction necessary
    - c. cathode material is dissolved in acid and components are separated
    - d. acid breaks down cathode structure
    - e. low energy needed due to low temperature
    - f. substrate foils are recovered directly
    - g. Li recovered by precipitation
    - h. Solvent extraction needed to separate Co and Ni or recover Co/Ni salt mixture
    - i. Output can be converted to cathode precursor
    - j. Can be used for any mixed cells
    - k. No valuable product from LFP (Lithium Iron Phosphate)
  3. direct recycling of batteries ([Figure 11](#))
    - a. is the recovery, regeneration and reuse of battery components directly without breaking down the chemical structure
    - b. not demonstrated on industrial scale, first pilot plant expected in 3 - 4 years in the USA
    - c. retains valuable chemical structure by separating multiple cathode chemistry materials but degradation my limit repeats
    - d. could be used for manufacturing scrap at low volumes
    - e. low energy needed due to low temperature
    - f. enables recovery of more materials so most impacts of virgin material production avoided

In [Table 3](#) the main data for comparing the three recycling options for batteries are shown. In [Figure 12](#) it is shown, that the recycling processes are interlinked.

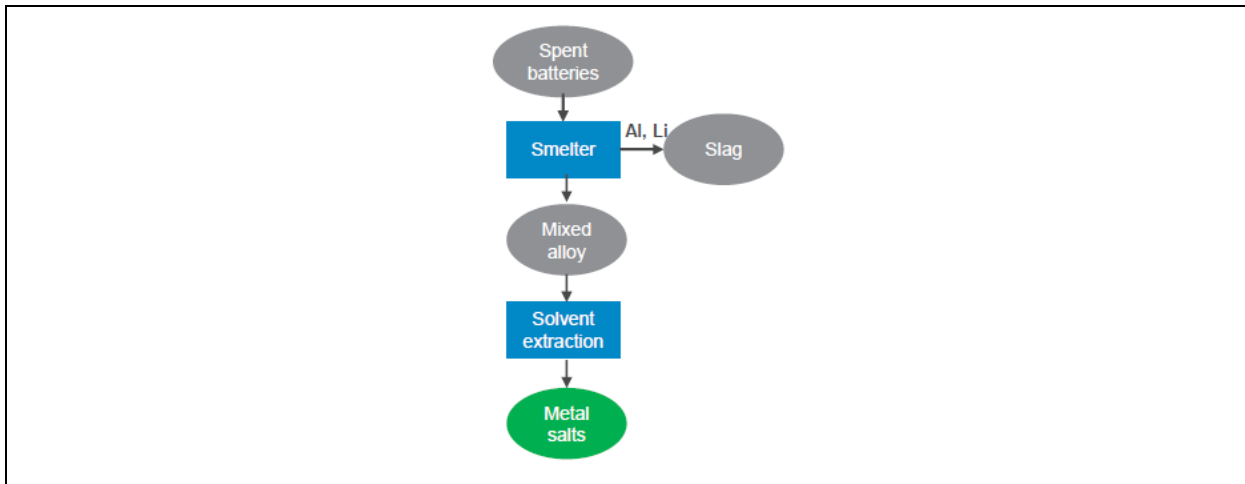

Figure 9: Scheme of pyro process recycling of batteries

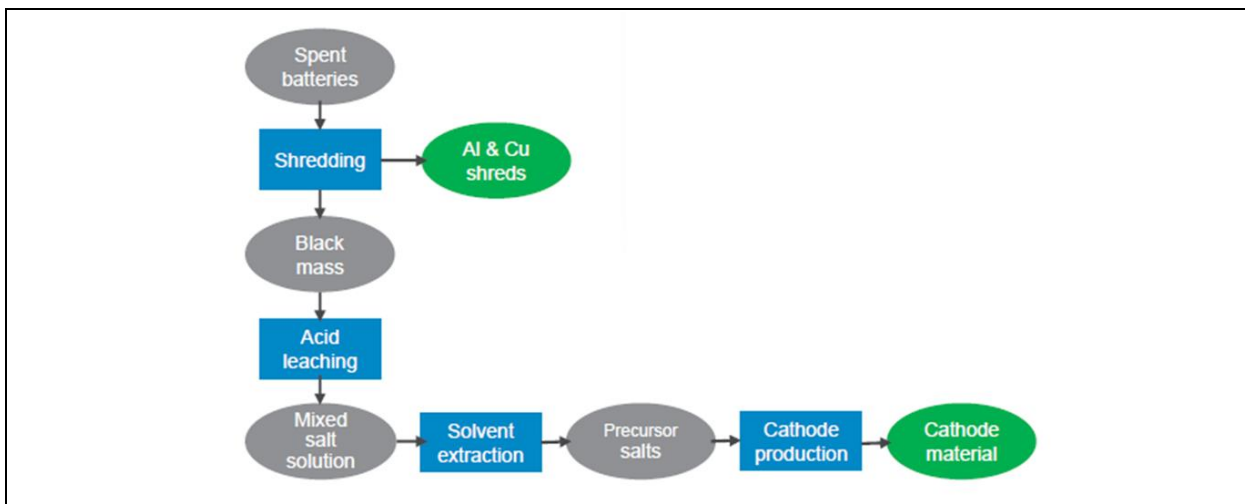

Figure 10: Scheme of hydro process recycling of batteries

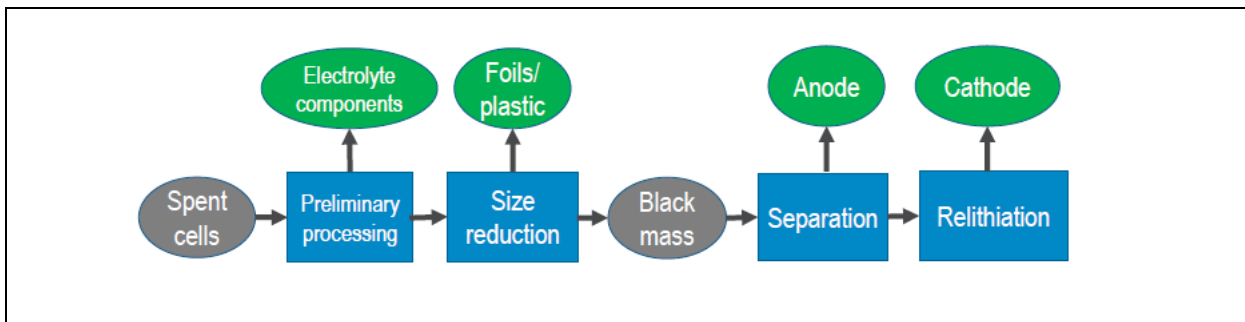

Figure 11: Scheme of direct recycling of batteries to recovery most materials (Gaines 2019)



Table 3: Main data for comparing recycling processes (Gaines 2019)

	Pyrometallurgical	Hydrometallurgical	Direct
Material input	Sand; limestone; HCl; H <sub>2</sub> O <sub>2</sub>	HCl; H <sub>2</sub> SO <sub>4</sub> ; NaOH; NH <sub>4</sub> OH; H <sub>2</sub> O <sub>2</sub> ; Na <sub>2</sub> CO <sub>3</sub>	Li <sub>2</sub> CO <sub>3</sub> ; CO <sub>2</sub>
Material output	Ni/Co salts; Cu/Fe alloy; Al and Li in slag	Ni/Mn/Co/Li salts; Al/Cu/steel; carbon	Cathode powder; Al/Cu/steel; electrolyte; carbon
Process energy	5.3 MJ/kg cell	3.2 MJ/kg cell	3.3 MJ/kg cell
Temperature	High	Low	Low

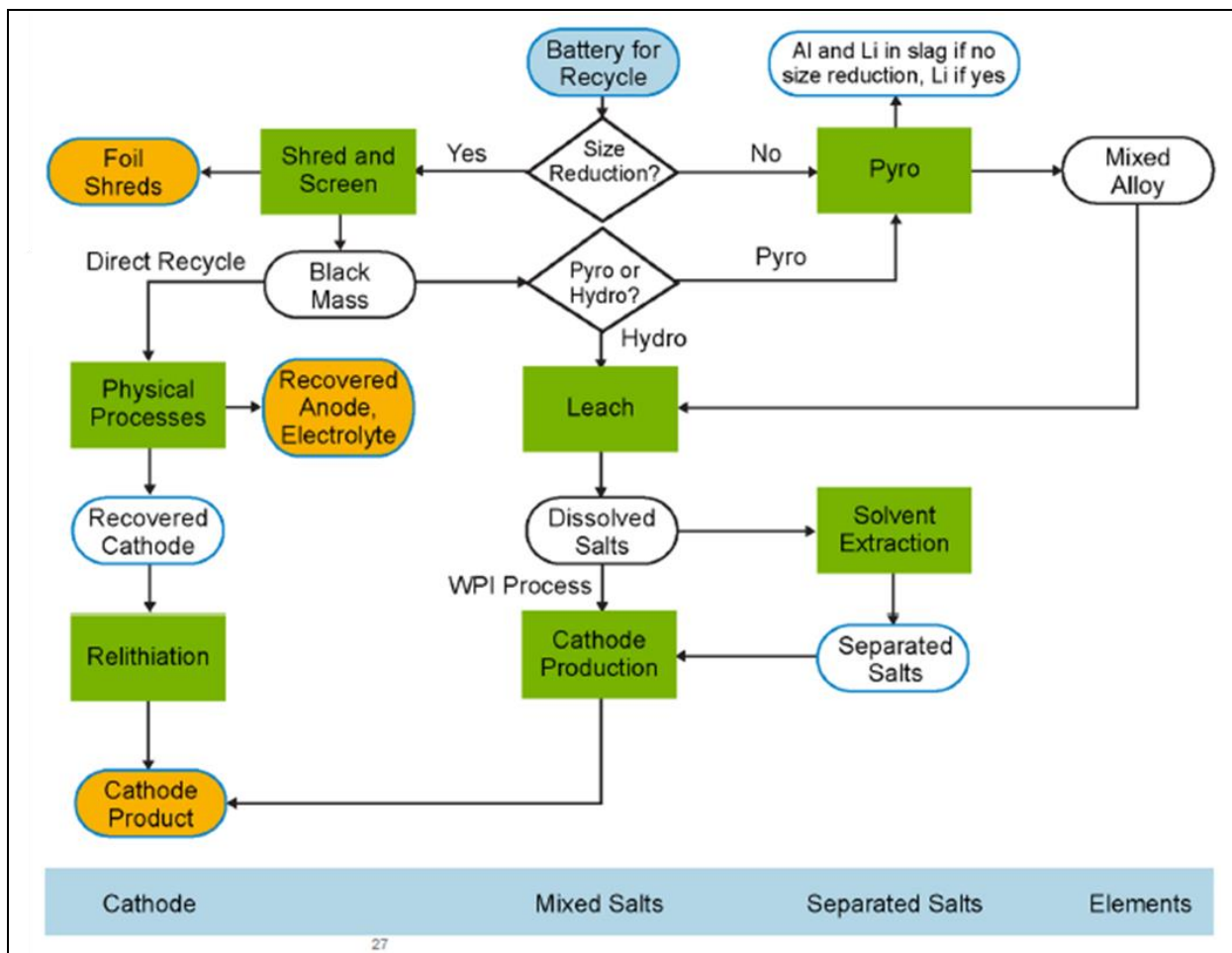

Figure 12: Recycling processes are interlinked (Gaines 2019)

The EVERBATT Model (<https://www.anl.gov/egs/everbatt>) helps to make more informed battery recycling decisions and help to accelerate the development of more sustainable supply chains for batteries. The EXCEL-based platform makes it possible to run the recycling module at a high level with less input parameters, as it customized hundreds of input parameters for detailed process and equipment specific information. It provides results on the following environmental impacts:

- Energy consumption
- Water consumption
- GHG emission and
- Air pollutant emissions

In [Figure 13](#) Figure 13: Cost and environmental impact comparison for 1 kg of NMC111 powder (Gaines 2019) the cost and environmental impact comparison for 1 kg of NMC111 (Nickel Manganese Cobalt) powder is shown, where direct recycling represents a promising opportunity to reduce the environmental impacts of cathode materials. Recycling of batteries reduced all emissions and energy use.

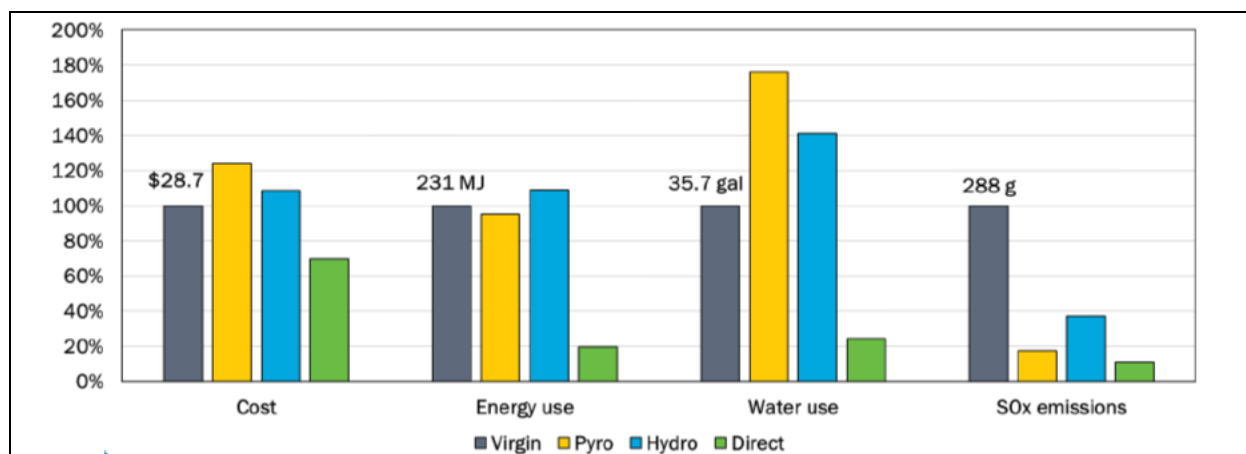

Figure 13: Cost and environmental impact comparison for 1 kg of NMC111 powder (Gaines 2019)

#### 4.2.2 Three German projects on Battery Recycling

The LCA on battery recycling from the following three German projects were presented:

- LiBRi – Lithium-ion Battery Recycling Initiative (2009-2011): partners Umicore, Daimler, TU Clausthal University IFAD
- LithoRec I+II - Recycling of LIB (2009-2011 and 2012-2016): partners TU Braunschweig University, Audi, Rockwood Lithium, Electrocyling, (Evonik Litarion), (Walch Recycling), H.C. Starck, I+ME Actia, (Recylex), (Süd Chemie), Münster University, Volkswagen; [Hosokawa Alpine], [Solvay Fluor]\*
- EcoBatRec - Demonstration plant for a cost-neutral, resource efficient processing of spent LIB (2012-2016): partners Accurec Recycling GmbH and RWTH Aachen University

The process concepts and the research focus of the LCA of lithium-ion batteries (LIB) of these three projects were

- LiBRi
  - Manual dismantling up to cells
  - Pyrometallurgical treatment of cells
  - Hydrometallurgical treatment of Co/Ni/Cu-alloy & slag (incl. Li)
  - Recovery:  $\text{CoSO}_4$  (Cobalt(II)-sulfat),  $\text{NiSO}_4$  (Nickel(II)-sulfat),  $\text{LiCO}_3$  (Lithiumcarbonat)
- LithoRec I+II
  - Manual dismantling up to cells
  - Mechanical treatment of cells
  - Hydrometallurgical treatment of active mass
  - Recovery:  $\text{CoSO}_4$  (Cobalt(II)-sulfat),  $\text{NiSO}_4$  (Nickel(II)-sulfat),  $\text{LiOH}$  (Lithiumhydroxid)
- EcoBatRec
  - Manual dismantling up to battery module
  - Thermal pyrolysis
  - Mechanical treatment
  - Evaporation of Li
  - Pyromet. Treatment of cathode powder & Co-Ni-recovery
  - Recovery:  $\text{CoSO}_4$ ,  $\text{NiSO}_4$ , Li

The functional unit was the recycling of 1,000 kg LIB from automotive application. The data on recycling processes from research test runs of demonstration plants laboratory experiments.

In [Figure 14](#) the LCA results from LithoRec II and in [Figure 15](#) from EcoBatRec are shown. In all cases the credits of primary material production given for the recovered materials over compensate the environmental effects from the recycling processes.

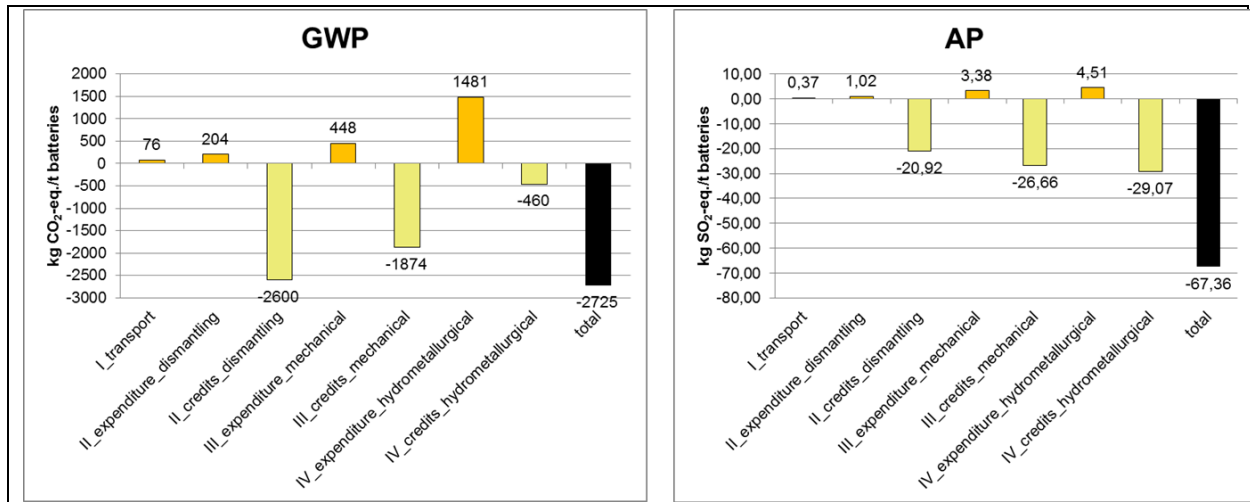

Figure 14: LCA results from LithoRec II (Merz 2019 from Buchert and Sutter (2016): <https://www.erneuerbar-mobil.de/sites/default/files/2017-01/LithoRec%20II-LCA-Update%202016.pdf>)

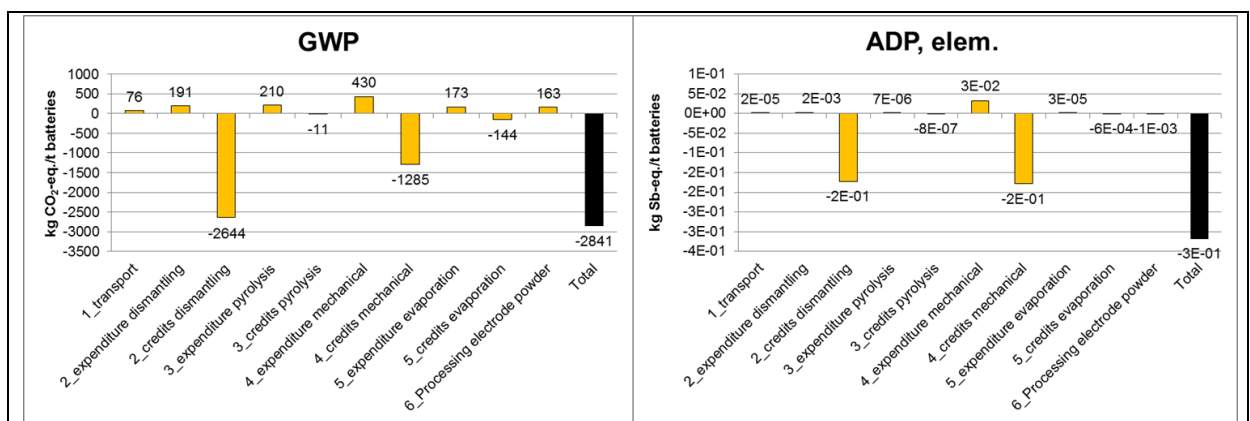

Figure 15: LCA results from EcoBatRec (Merz 2019 from Buchert and Sutter (2016): <https://www.erneuerbar-mobil.de/sites/default/files/2017-01/LithoRec%20II-LCA-Update%202016.pdf>)

The key conclusions are

- Careful dismantling offers significant environmental benefits.
- Major credits from housing materials and other components.
  - credits from recycling of steel, aluminium, and copper
  - credits from recycling of precious metals (from battery management systems)
- Recycling of battery cells
  - credits for Co, Ni, Cu; primary production of Co with high uncertainty -> LCI data in 2017 by CDI
  - in principle, it is possible to recycle lithium but process has to be implemented
- Huge importance for attenuating pressure on primary demand for key materials

### 4.2.3 EV Trends for Tomorrow’s Material Resources and Life Cycle Emissions

#### 4.2.3.1 Effects of trends of EV development on battery recycling

The main implications of current trends in EV development that matter for vehicle LCA are

- Likely to be bad: Large, high-performance EVs mean larger batteries, and designs that may not focus on efficiency, or do so by investing in lightweight materials
- Likely to be good: Increasing range means that batteries may last much longer, reduce barriers to adoption, be used in higher-mileage operations

Therefore a study was done to conduct preliminary LCA focusing on production and use of new-model and future EVs in which the important temporal dynamics, like changing electricity fuel mixes and spatial factors like region of operation were considered (Kendall 2019). The modelling approach covered

- three archetypal EVs:
  - EOV: Efficiency-oriented compact vehicle (e.g. Chevy Bolt)
  - PLS: Performance luxury sedan (e.g. Tesla Model S)
  - PSUV: Performance SUV (e.g. Tesla Model X)
- Use scenarios to explore space, time and use models, and longer-range vehicle designs.

In [Figure 16](#) the results on GHG emissions are shown. The main conclusions are

- Many conclusions echo those of previous work (e.g. where you charge matters)
- Perhaps the most notable finding is the relative contribution of emissions from vehicle and battery production on a g/mile basis
  - This gets more important over time, and will grow if high-performance/large vehicles are preferred in EV designs and sales
  - Do we need life-cycle based fuel economy standards to achieve climate mitigation goals?

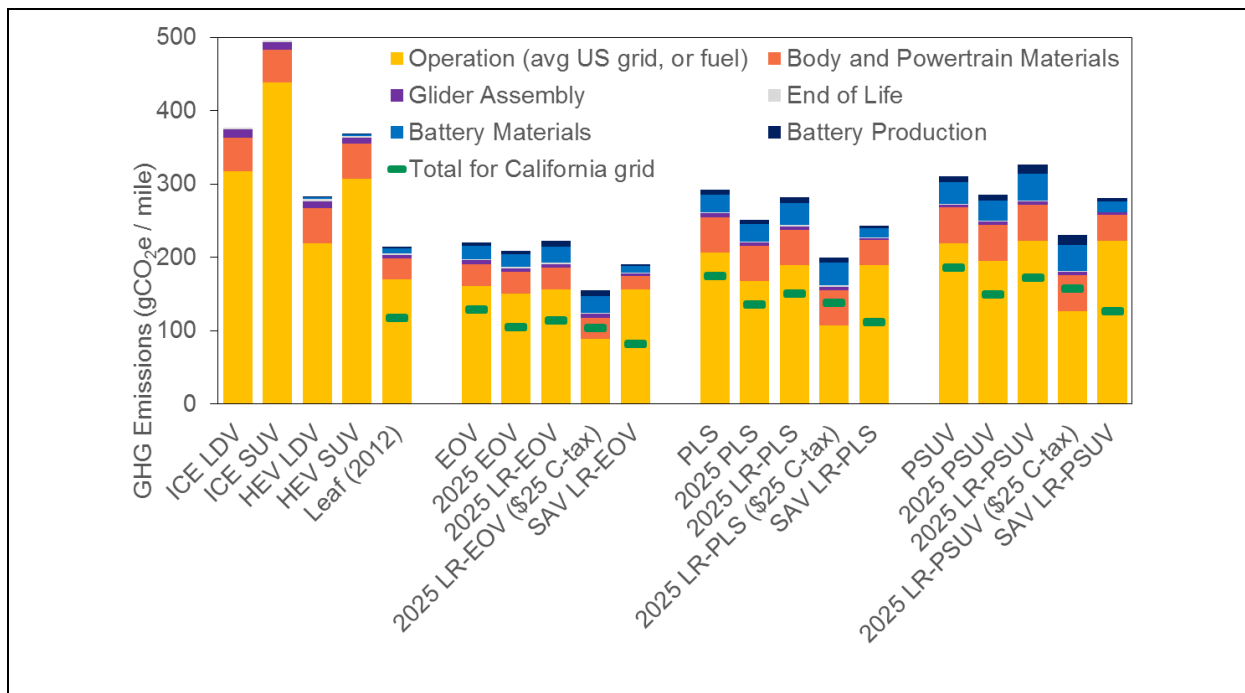

Figure 16: Results on GHG emissions (Kendall 2019)

#### 4.2.3.2 Effects of trends of EV on material resources

The background on material resources covers

- Lithium ion EV batteries (LIBs) and traction motors depend on a short list of materials with unique properties and few substitutes.
- Material “criticality” arises from the potential mismatch of resource demand and supply, a problem especially during rapid increases in demand.
- Despite its relative abundance in the lithosphere, the U.S. identifies Li as a critical energy material

In [Figure 17](#) the demand of lithium for batteries is shown. The ramification of this trend means Lithium production will expand by increasing capacity at existing sites as well as accessing new resources. A study was performed (Kendall 2019) to understand how resources are likely to be developed, whether serious constraints are likely to occur, and whether the environmental intensity of Li is likely to change as additional resources are brought into production. The approach of the study was ([Figure 18](#))

- Develop a demand model (high (optimistic) and low (conservative) scenarios)
- Develop a spatially explicit resource model with production costs as a function of resource type and ore grade



- Model future lithium production and link to LCA model

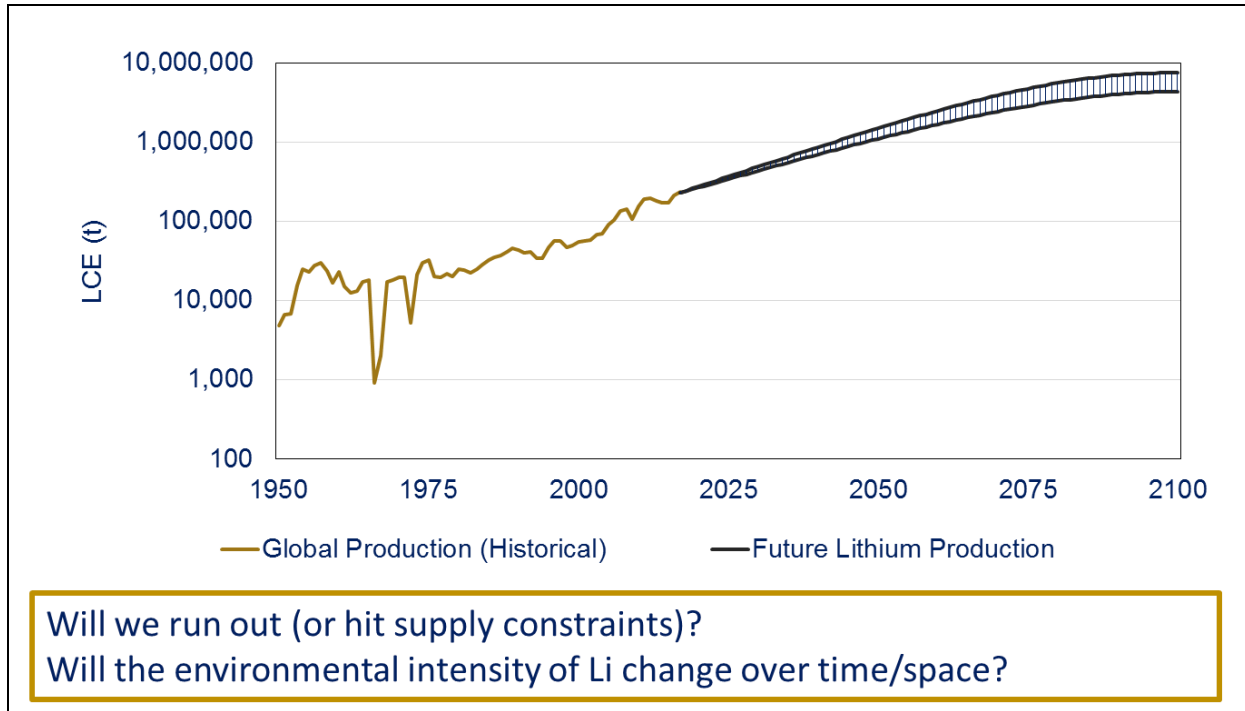

Figure 17: Lithium for batteries (Kendall 2019)

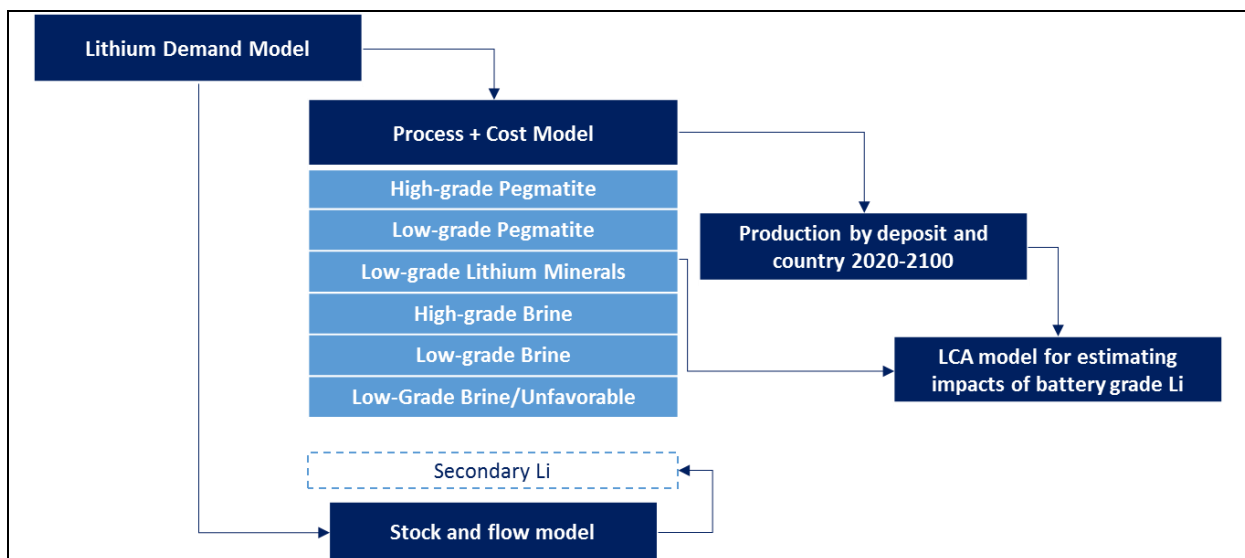

Figure 18: Model approach and data (Kendall 2019)



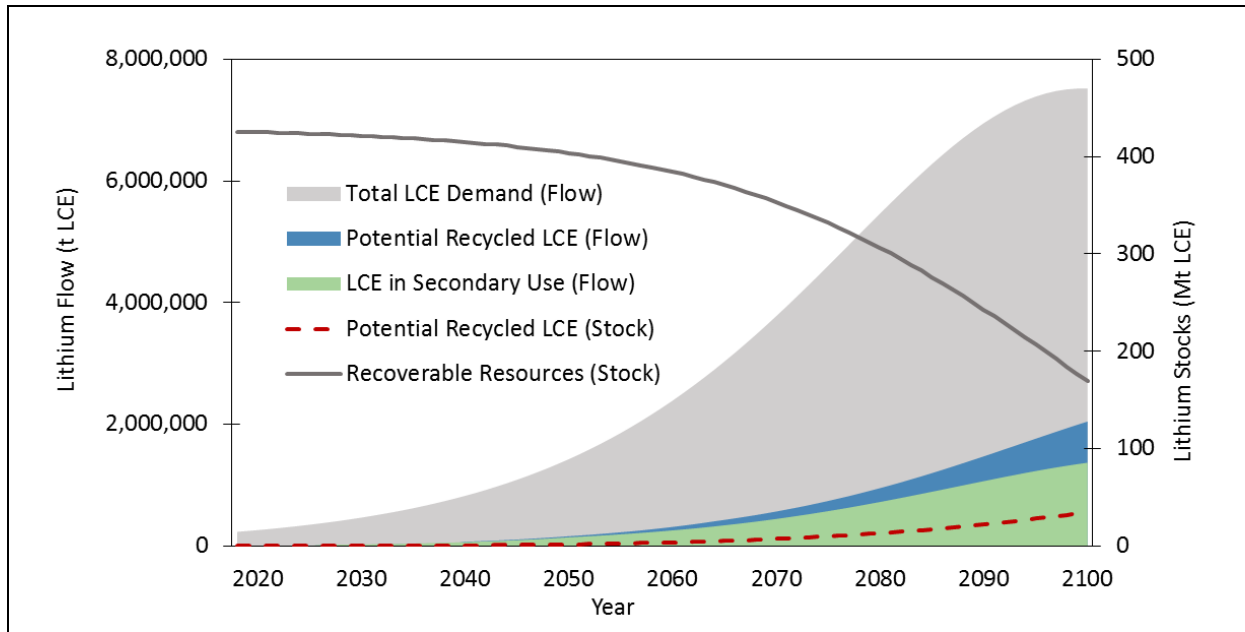

Figure 19: Recycling will play a limited role at least in the coming decades (Kendall 2019)

In Figure 20 the impacts per resource types are shown. The main conclusions are

- Increasing demand will shift resources to new sources, but will mostly just expand existing resources until around 2080
- The impact of Li production does not change on a per-mass basis
- The total amount of Li produced increases dramatically, so the impact of Li (especially on proximal communities) may increase dramatically

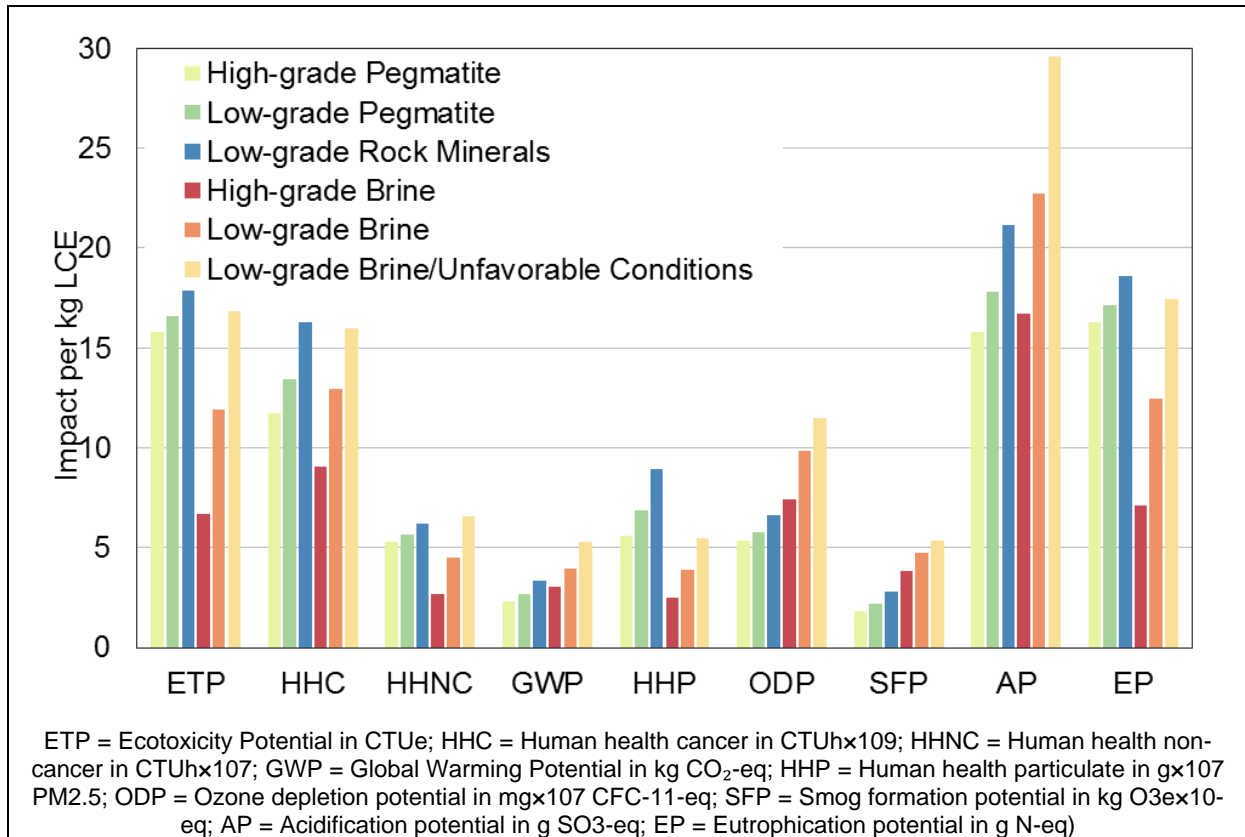

Figure 20: Impact per resource type (Kendall 2019)

### 4.3 LCA of electric motor recycling (magnets)

The LCA was performed within the project MORE – Recycling of components and strategic metals from electric motors. The following 3 different processing routes were analysed with the major interest to recover Neodym (Ny) and Dysprosium (Dy) using the generic composition shown in [Figure 21](#):

1. Direct reuse (cleaning): Production of 1 kg magnet via reuse
2. Remelt (closed loop magnet remelting): Production of 1 kg secondary magnet (70% prim / 30% sec)
3. Feedstock recycling (recovery of rare earth oxides from EoL-magnets): Production of 1 kg RE oxide (mixed or separated)

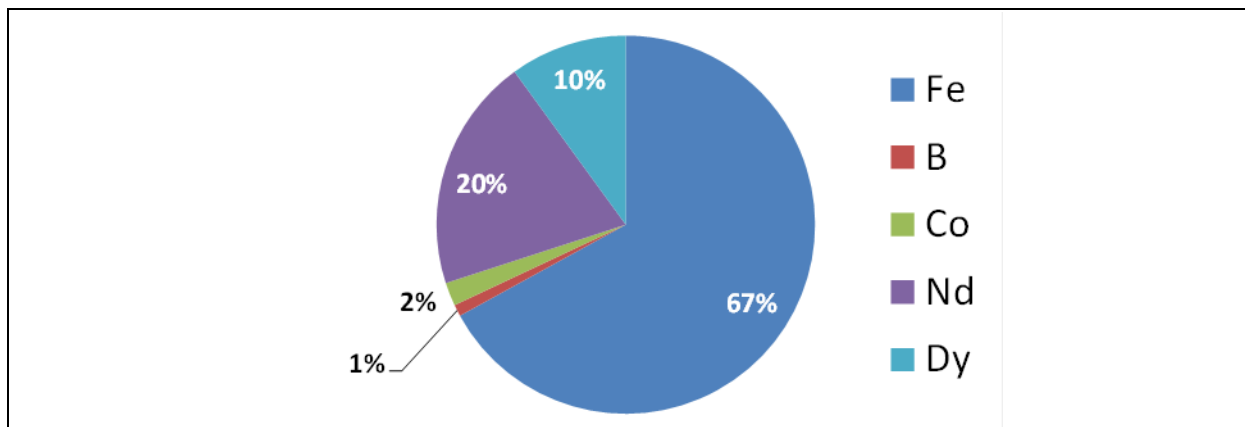

Figure 21: Generic composition of NdFeB-magnets (Merz 2019)

The LCA results for GHG emissions electric motor recycling (magnets) are shown in [Figure 22](#) for remelt (70% prim/30% sec) using different allocations of impacts to Nd and Dy and in [Figure 23](#) for feedstock recycling (incl. separation).

The key conclusions are

1. Major GHG emission credits for recovery of RE oxides, also remelting with secondary share of 30% offers benefits
2. GHG emissions of recovery effort generally well outweighed by credits for Nd and Dy oxides, magnitude strongly depends on allocation method (economic or mass based)
3. Also other categories show strong credits for recovery of RE oxides
4. Data availability for assessment of primary production of RE, especially dysprosium, very limited -> uncertainty

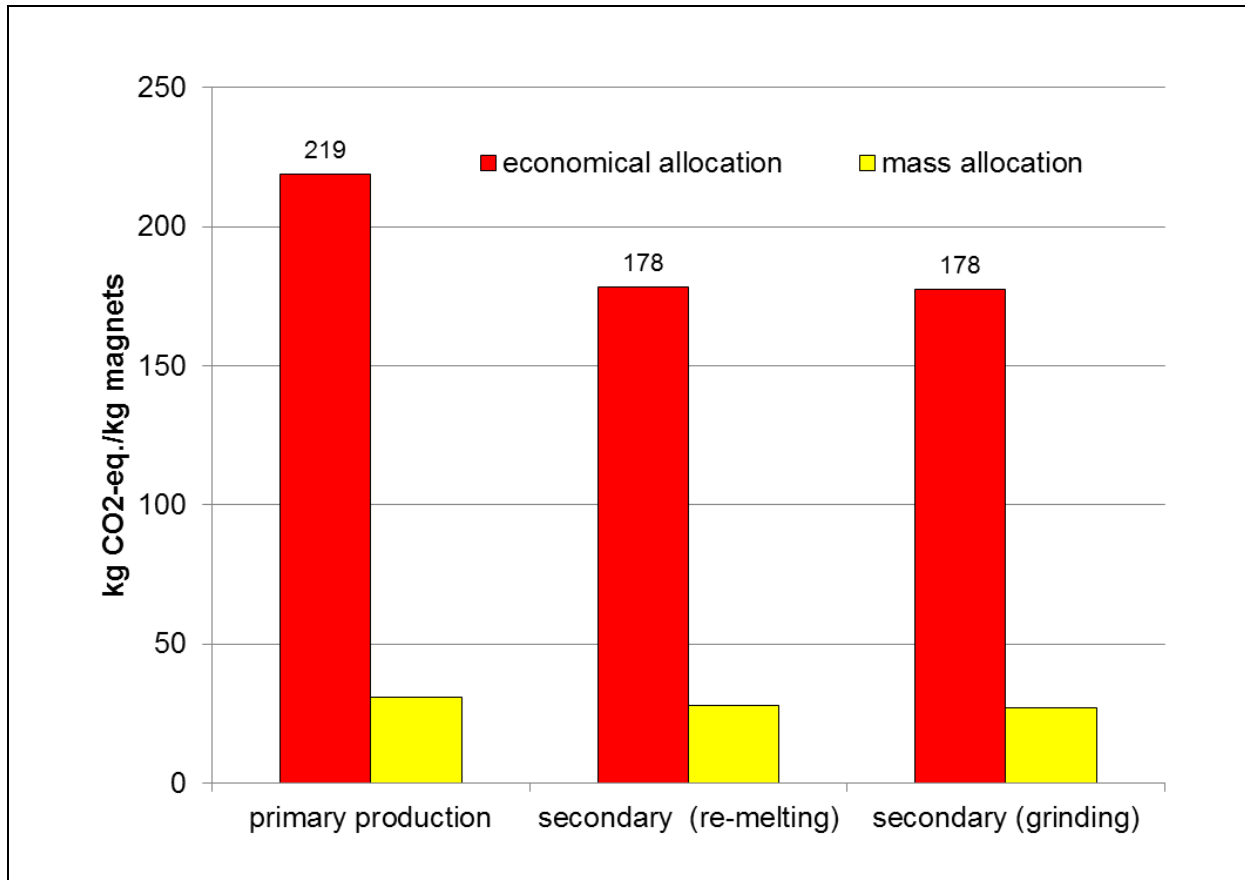

Figure 22: GHG emissions electric motor recycling (magnets) remelting (70% prim/30% sec) using different allocations of impacts to Nd and Dy (Merz 2019 from Walachowicz et al. (2014): <https://www.oeko.de/fileadmin/oekodoc/MORE-LCA-Endbericht.pdf>)

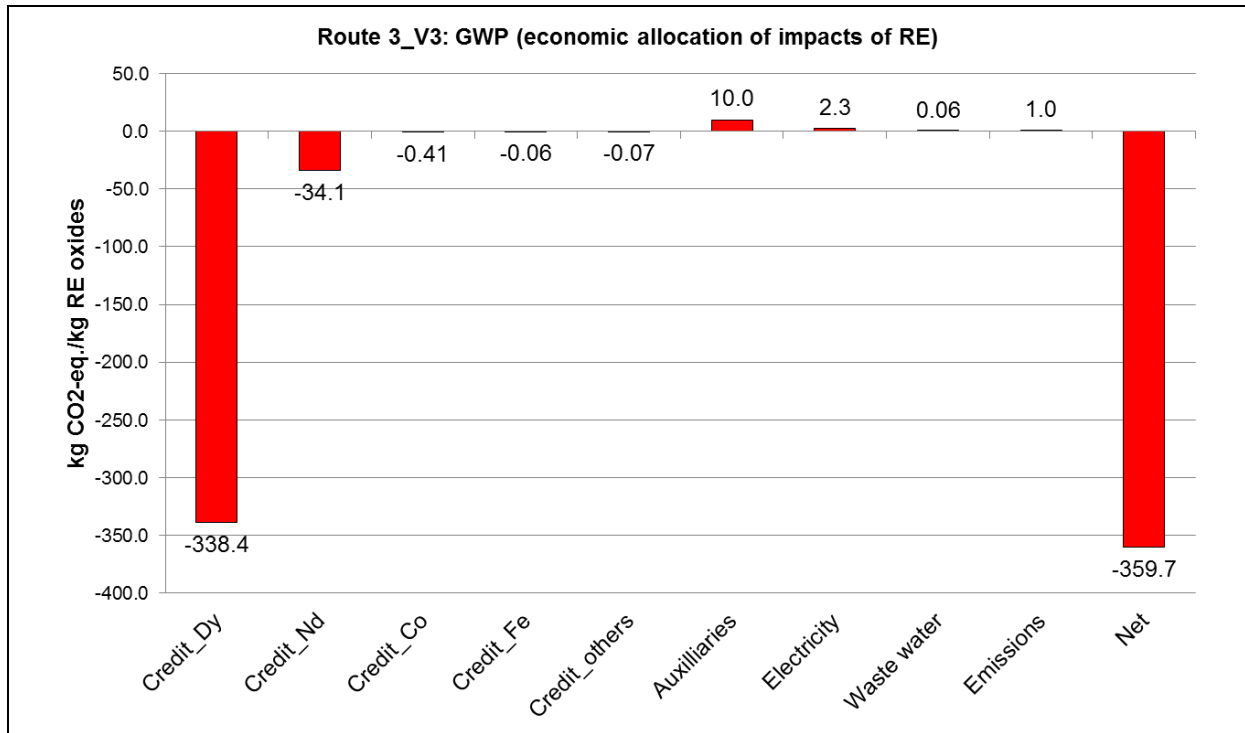

Figure 23: GHG emissions electric motor recycling (magnets) for feedstock recycling, incl. separation (Merz 2019 from Walachowicz et al. (2014): <https://www.oeko.de/fileadmin/oekodoc/MORE-LCA-Endbericht.pdf>)

#### 4.4 LCA of power electronics recycling

The LCA was performed within the project ElmoRel 2020 – Electric vehicle recycling 2020 – key component power electronics. The following 3 different processing routes were analysed

1. Conventional car shredder (reference route)
2. Dismantling & WEEE recycling of power electronics
3. [Dismantling & WEEE recycling of power electronics incl. chemical dissection of PCB]

The major interest of dismantling and dedicated WEEE recycling of power electronics is to increase recovery of

1. Sn: Tin
2. Au: Gold
3. Ag: Silver

and to facilitate recovery of

1. Pd: Palladium
2. Ta: Tantal

The LCA based GHG emissions of WEEE recycling route are shown in [Figure 24](#). The share of given GHG emission credits of WEEE recycling route are shown in [Figure 25](#). It is shown that the environmental effects for recycling are much lower than environmental benefit of substituting primary production, also in other evaluated categories. For GHG emissions by far largest credit derive from Al recycling. In other categories major contributions derive from Au & Cu (esp. EP, ADP), some Pd (in AP, POCP), Ag and Sn (ADP).

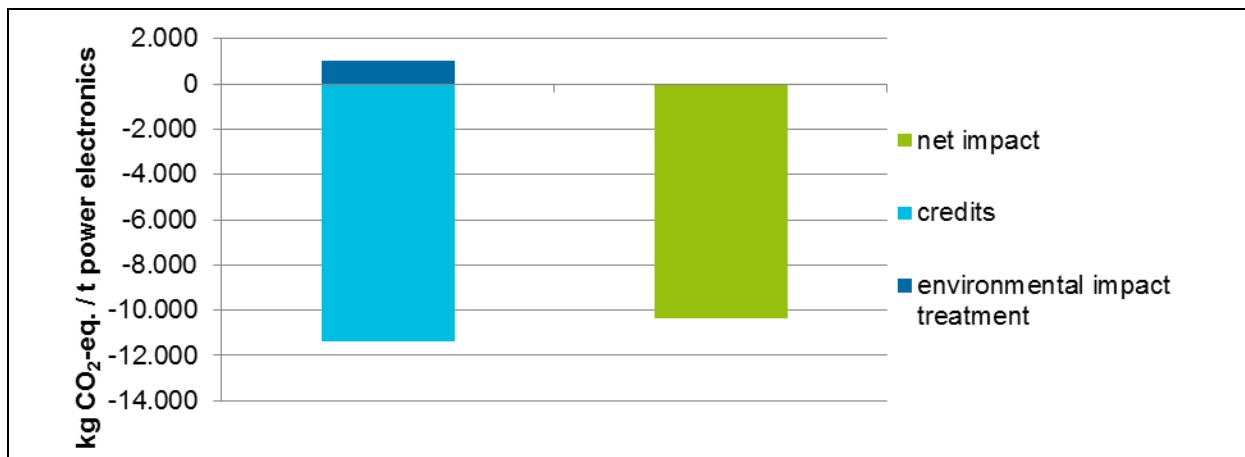

[Figure 24](#): GHG emissions of WEEE recycling route (Merz 2019 from Bulach et al. (2018): <https://doi.org/10.1177/0734242X18759191>)

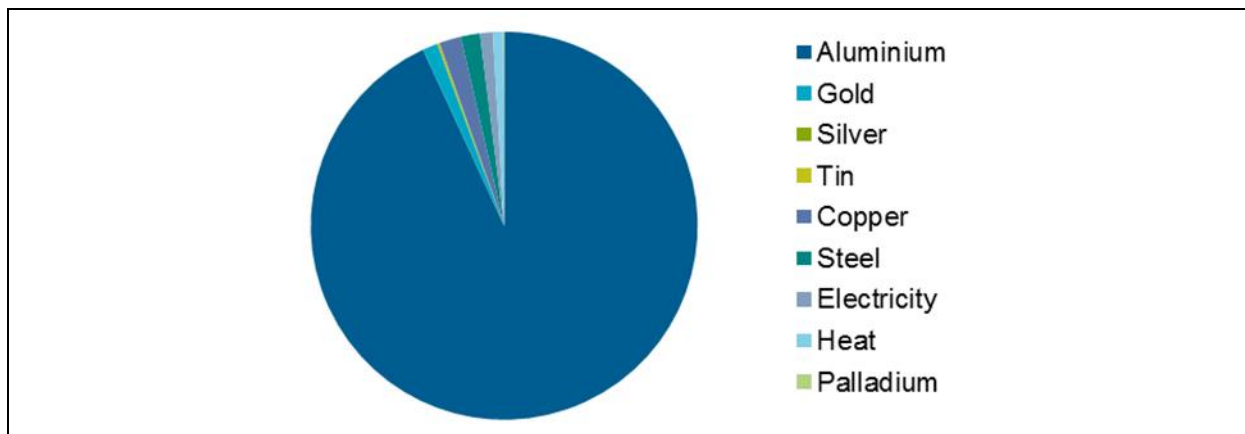

[Figure 25](#): Share of GHG emission credits of WEEE recycling route (Merz 2019 from Bulach et al. (2018): <https://doi.org/10.1177/0734242X18759191>)

The key conclusions are

1. In comparison to the conventional car shredder route extraction of power electronics unit enables high recovery rates for gold, silver and palladium; recovery rates of tin and copper can also be increased

2. LCA shows good results for both routes, with dedicated WEEE recycling providing additional benefits from some higher recovery rates and corresponding credits
3. Main benefit of dedicated WEEE recycling from a resource conservation perspective (ADPelem)
4. The effort for the additional recovery of Ta from PCB seems to be too high (chemicals) as to be environmentally attractive
5. The WEEE recycling route is economically viable, but offers a lower profit margin than the car shredder route

#### 4.5 Land use

Land use is relevant because

- More than half of the earth’s terrestrial land is actively being used by humans
- Resulting loss of biodiversity and soil functions expressed by ecosystem services is of scientific, political, societal and economic concern
- Many methods to address land use impacts in LCA developed
- Mandatory requirement: globally available, country specific as well as region specific characterization factors (CF)

Land use is correlated to occupation of land and transformation of land. In [Figure 26](#) the principle of land occupation and land transformation are shown. Starting with a land quality  $Q_{Ref}$  the land is transformed to another quality to be used and then occupied for a certain time. After the occupation the quality of the land is transformed to a new permanent quality.



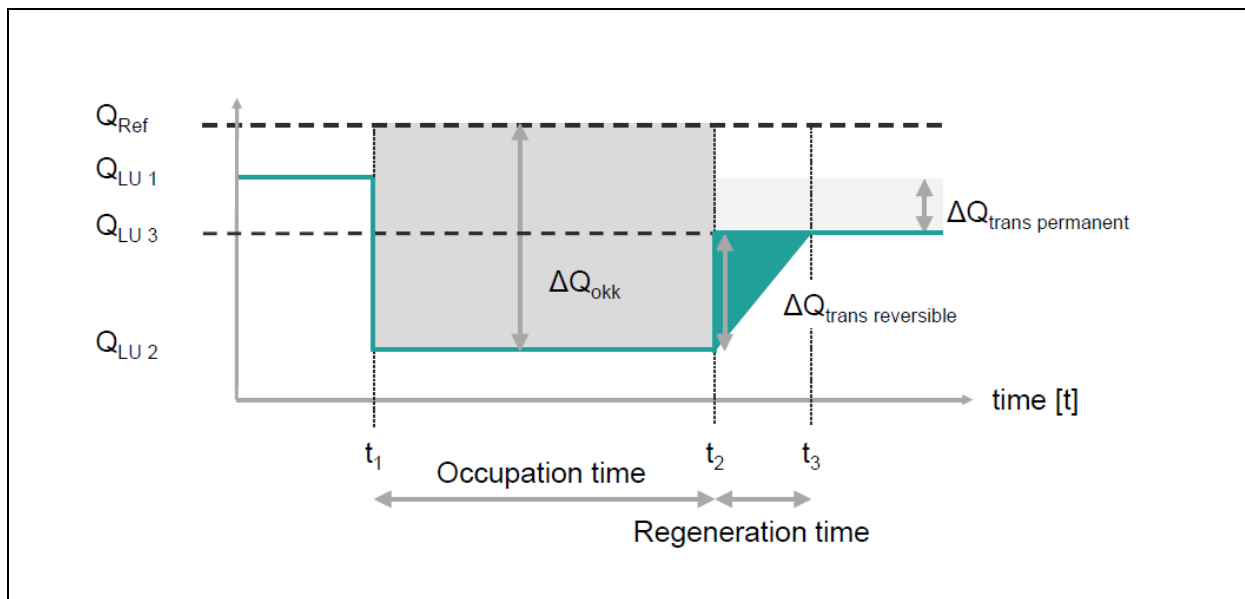

Figure 26: Occupation and transformation of land (Bos 2019)

In the software and database system GaBi, the ILCD elementary flows for land use are integrated and characterization factors (CF) for the LANCA® (Land Use Indicator Value Calculation in Life Cycle Assessment) indicators are provided.

The following set of indicators has been defined to model land use aspects in LCA:

- Erosion Resistance (Figure 28)
- Mechanical Filtration (Figure 29)
- Physicochemical Filtration (Figure 30)
- Groundwater Replenishment (Figure 31)
- Biotic Production (Figure 32).

On the inventory side country specific land use flows are used for “occupation” with the unit  $m^2 \cdot a$  and for “transformation from” and “transformation to” with the unit  $m^2$  for all different land use types as for example “arable, irrigated, intensive” or “forest”. The respective country specific characterization factors are integrated into the GaBi database and software in the impact assessment, and aggregated over the process chain to form environmental indicators that are representative for the entire life cycle. In the GaBi background processes land use information is addressed for all biomass and mining process. Through aggregation land use information is integrated in most of the processes. Therefore, land use can be considered as an additional aspect in LCA to extend its environmental impact evaluation.

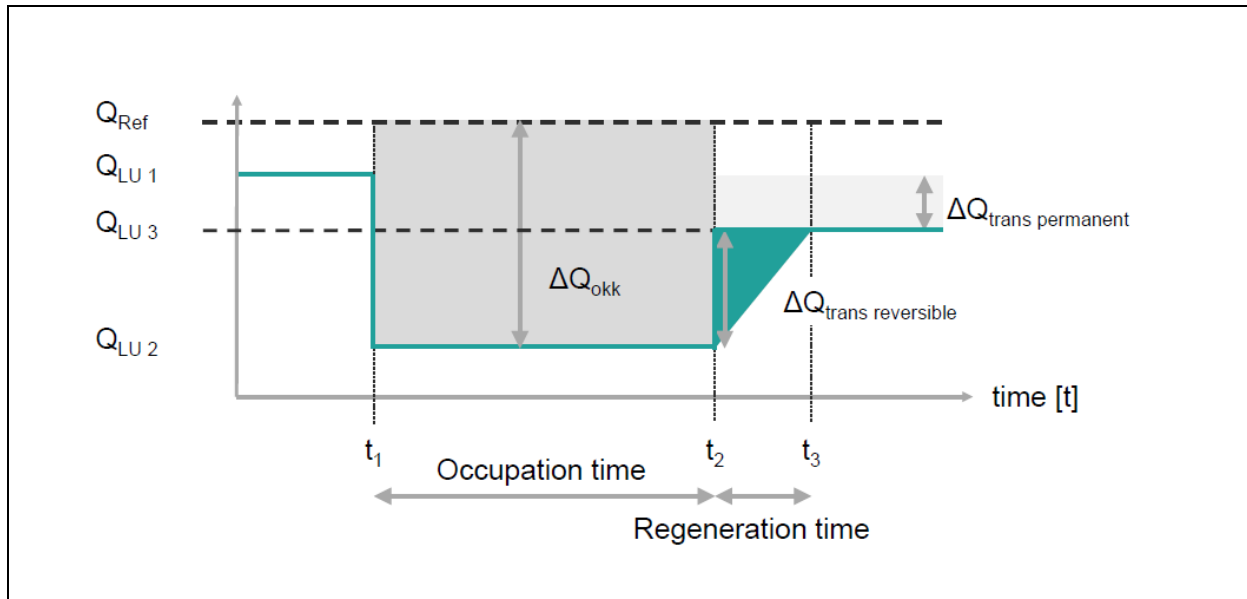

Figure 27: Occupation and transformation of land (Bos 2019)

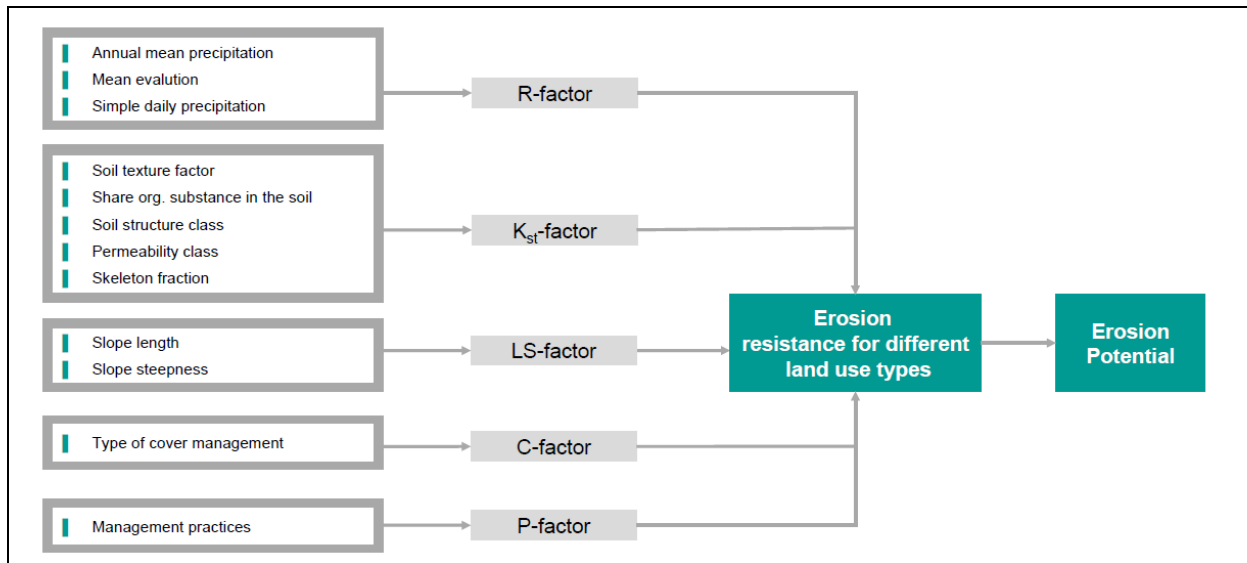

Figure 28: Erosion potential in LANCA (Bos 2019)

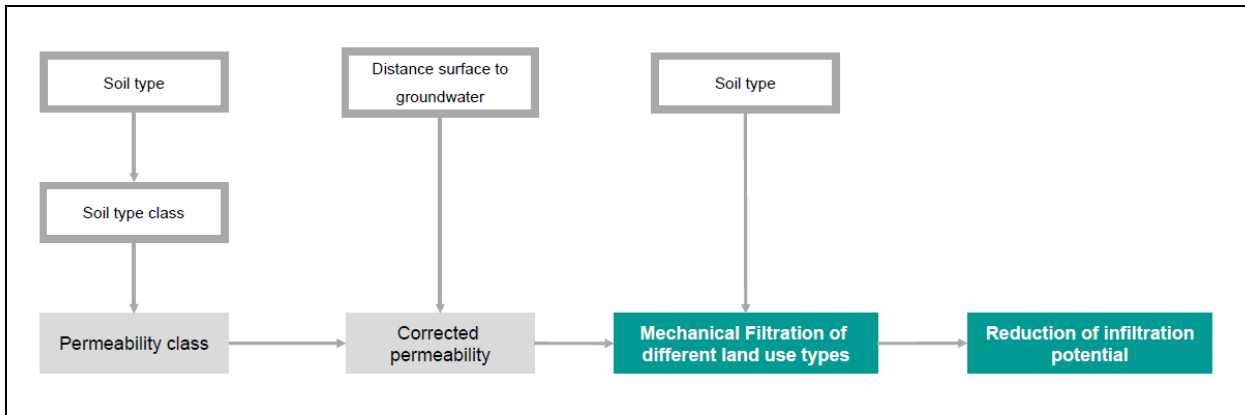

Figure 29: Reduction of infiltration potential in LANCA (Bos 2019)

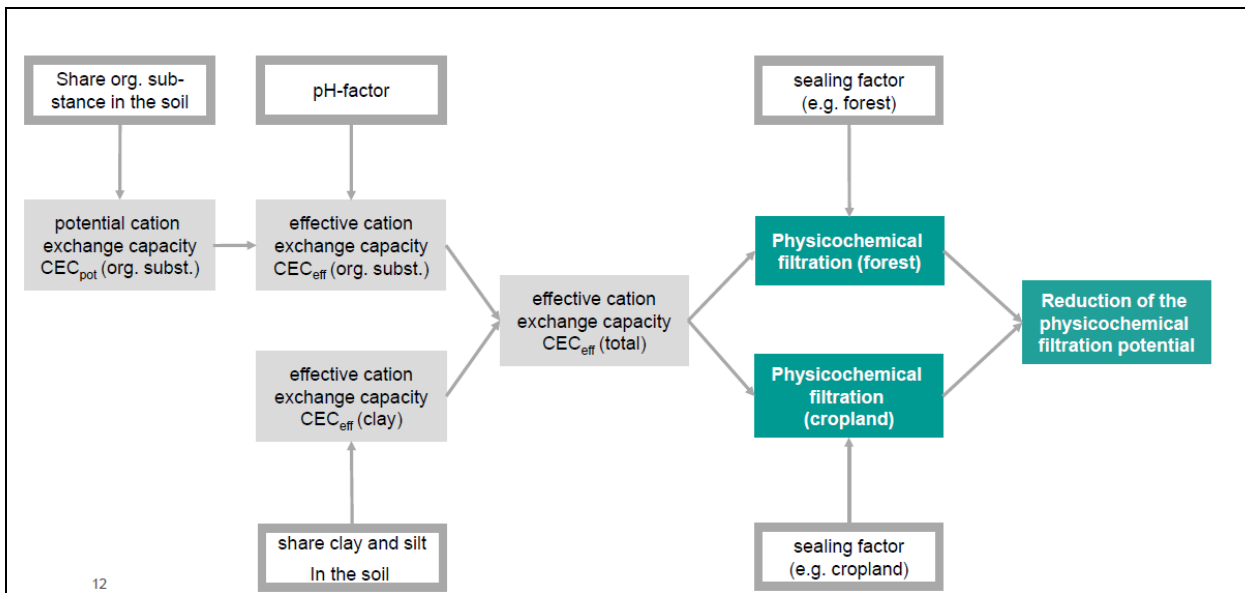

Figure 30: Reduction of physicochemical filtration potential in LANCA (Bos 2019)

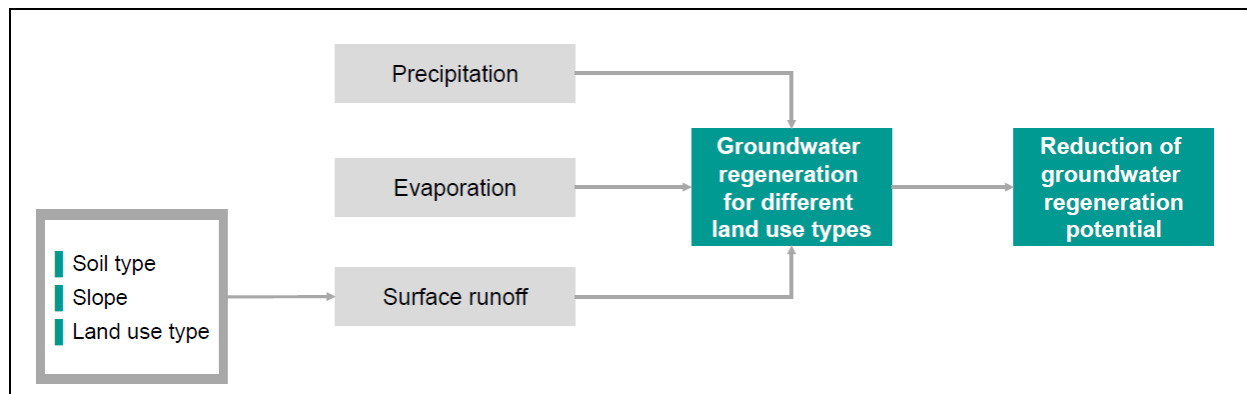

Figure 31: Reduction of ground water regeneration potential in LANCA (Bos 2019)

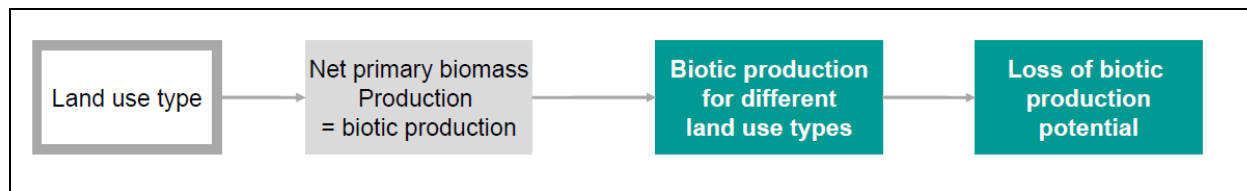

Figure 32: Loss of biotic reduction potential in LANCA (Bos 2019)

LANCA implemented in GaBi has land use inventory information for

- Mining
- Forestry
- Agriculture and
- some EoLprocesses integrated

The inventory data are relevant for occupation [m<sup>2</sup>\*a] and transformation. [m<sup>2</sup>]. But especially for mining processes these input data are often not known exactly and are therefore estimated.

## 4.6 LCA of autonomous vehicles

### 4.6.1 Introduction

The vehicle automatization is defined at multiple levels. The SAE (Society of Automotive Engineers) gives 5 levels, with 0 level for no automatization (other definitions exist, but SAE has been widely adopted)

- Level 1 – 2 require significant human interaction/monitoring of the environment all the times, and the human driver will serve as the fall back plan, and this only apply to some driving modes, e.g. cruise control, lane keeping, parking
- Level 3 – 5 have increasing degrees of “full automatization” where the vehicle system is responsible for sensing, actuation, and environment monitoring

- Level 3: certain driving conditions, but driver must be able to intervene
- Level 4: certain driving conditions, no driver intervention
- Level 5: all conditions, no intervention

The promises of vehicle automatization are

- Convenience for drivers and passengers
- Reduced congestion
- Increased safety
- Increased productivity
- Faster travel
- Vehicle platooning (improved efficiency)
- Lower “taxi” costs (taxi here is inclusive of mobility as a service companies)
- Drive smoothing (less abrupt start and stops)
- Right vehicle for the trip (mode matching)

The challenges of vehicle automatization are

- Rebound effect for distance lived from work
- Increased number of trips, especially taxi trips
- Empty miles (dead-heading)
- Automated hunting for parking
- Safety concerns
- Equity and job less

### 4.6.2 Additional equipment

The automatization requires additional sensors for vehicles at different SAE levels ([Table 4](#)), and their configuration can be like shown exemplary for sensors for SAE level 3 in [Figure 33](#).

In [Figure 34](#) visual example for these possible components are shown.

In [Table 5](#) the possible characteristics of components for automated vehicles are shown. In [Table 6](#) these sensors are combined to different technology packages for level 3 and 4/5, where from a technological point of view, there is no difference between SAE level 4 and 5. Additional connectivity packages shown exemplary in [Table 7](#) are necessary for automated vehicles, which require additional infrastructure and energy. In [Figure 35](#) the possible share of electric power for the sensors on the different automatization levels is shown.

**Table 4:** Sensor requirements for vehicles at different SAE levels (Ehrenberger 2019)

SAE level	RADAR	ULTRASONIC	LIDAR	CAMERA	Total
1	1	8	-	1	<u>10</u>
2	3	12	-	3	<u>18</u>
3	5	12	1	6	<u>24</u>
4	6	12	4	6	<u>28</u>
5	8	12	4	7	<u>31</u>

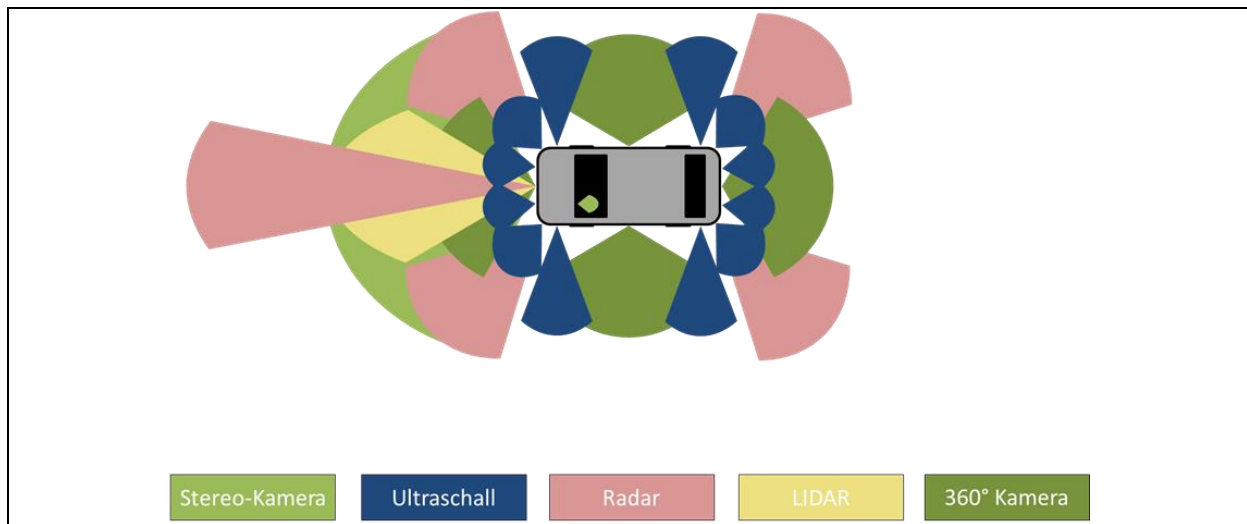

**Figure 33:** Example: Configuration of sensors for SAE level 3 (Ehrenberger 2019)



**Figure 34:** Example for possible components (De Kleine 2019)

**Table 5:** Possible Characteristics of components for automated vehicles (Ehrenberger 2019)

Components	Name / Manufacturer	Average power [W]	Weight [g]	Project / Vehicle
LIDAR	Velodyne Ultra Puck	10	925	Baidu Apollo Project
Radar	Continental ARS 408-21 Premium	7	320	Baidu Apollo Project
Kamera	Continental MFC500	7	200	Baidu Apollo Project
Ultrasound	Bosch Ultraschallsensor	0,1	14	Tesla Motors
Communicaiton unit	Cohda MK5 Module	6	2654	Jaguar Land Rover
GPS	Novatel PwrPak7D	3	620	Baidu Apollo Project
CPU/GPU/AI	Nvidia Drive Pegasus	500	10000	Daimler-Bosch-Nvidia
Data storage	4 x Toshiba MQ01AAD032C + ADATA IPC39 MLC (2 TB)	13	112	Allgemein
ECU	TTTech HY-TTC 580	3	1200	Allgemein
Actuator	-	50	-	-
Display	Signage Solution Display	6	710	Allgemein

**Table 6:** Possible technology packages for SAE level 3 (left) and 4/5 (right) (Ehrenberger 2019)

Components	Number	Power [W]	Weight [g]	Components	Number	Power [W]	Weight [g]
LIDAR	1	10	925	LIDAR	4	40	3700
Radar	5	33	1600	Radar	9	53	2560
Camera	6	42	1200	Camera	7	49	1400
Ultrasound	12	1.2	168	Ultrasound	12	1.2	168
Communicaiton unit	1	6	2654	Communicaiton unit	1	6	2654
GPS	1	3	620	GPS	1	3	620
GPU/CPU/AI	1	50	710	GPU/CPU/AI	1	500	10000
Processors	2	5	2400	Data storage	1	13,2	112
Display	1	6	710	Processors	3	7,5	3600
Harness/Structures	-	-	13600	Display	4	24	2840
Actuators (Steering / Breaking Systems)	-	25	-	Harness/Structures	-	-	19600
Total	-	<b>0.16 kW</b>	<b>23.1 kg</b>	Actuators (Steering / Breaking Systems)	-	50	-
				Total	-	<b>0.75 kW</b>	<b>47.25 kg</b>

**Table 7:** Possible connectivity packages (Ehrenberger 2019)

GPS/Maps	V2V (Vehicle-to-Vehicle)	V2I (Vehicle-to-Infrastructure)	V2X (Vehicle-to-Everything)
High-precision digital maps (gradients, curves, pedestrian crossings, etc.)	Communication with other road users + GPS/Maps	Communication with infrastructure (traffic lights, car parks, etc.) + GPS/Maps	Communication with other road users and infrastructure + GPS/Maps



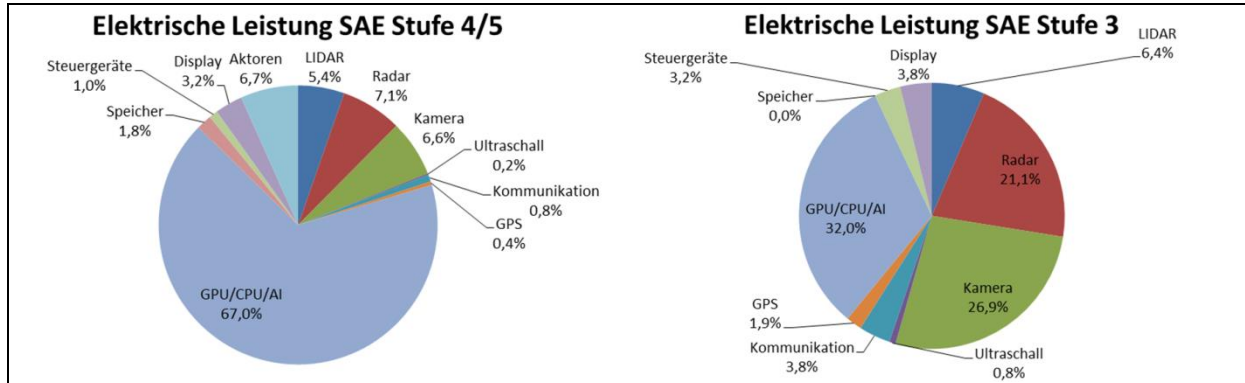

Figure 35: Possible share of electric power for the sensors on the different automatization levels (Ehrenberger 2019)

#### 4.6.3 Influence on energy demand

In Figure 36 the preliminary analysis of the upper (left) and lower bound (right) of possible impacts from autonomous vehicles is shown for the effect on the base line energy usage. The key factors are the change in demand and in efficiency. So in total a significant increase but also decrease might be possible.

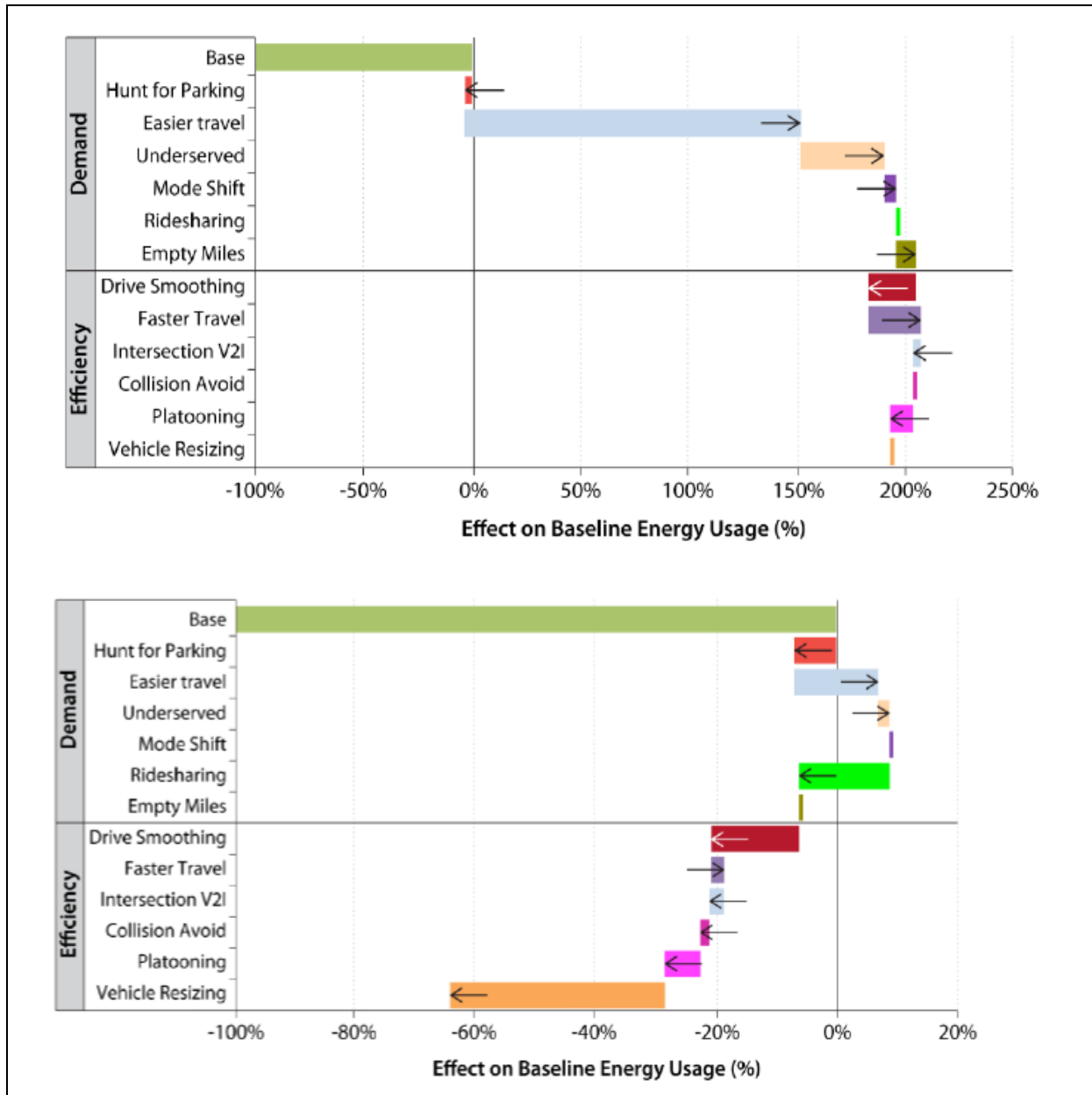

Figure 36: Preliminary analysis of the upper (top) and lower bound (bottom) of possible impacts from autonomous vehicles (Stephans et al 2016, taken from Kelly 2019)

By modelling the possible energy consumption of autonomous vehicles different energy saving strategies can be used, for which possible parameters chosen based on literature review are shown in Table 8. In Table 9 possible results of the energy consumption model using different application levels for automated vehicles are shown, where in most of the cases an energy consumption reduction is possible.

**Table 8:** Energy saving strategies and parameters chosen based on literature review (Ehrenberger 2019)

Energy saving strategy	Energy saving potentials (adapted from literature)
Avoidance of traffic	0 – 4%
Eco-Routing	5%
Eco-Driving/Smoothing of traffic (SAE 3)	0 – 10%
Eco-Driving/Smoothing of traffic Motorway (SAE 4,5)	0 – 20%
Eco-Driving/Smoothing of traffic City (SAE 4,5)	0 – 20%
Platooning/CACC (SAE 3)	0 – 12%
Platooning/CACC (SAE 4,5)	0 – 20%
Car park routing (SAE 3)	0 – 2%
Car park routing (SAE 4,5)	0 – 6%
Intersection V2I Communication (SAE 3)	0 – 2%
Intersection V2I Communication (SAE 4,5)	0 – 6%

**Table 9:** Possible results of the energy consumption model using different application levels ( $A_f$ ) (Ehrenberger 2019)

$A_f$	SAE 3		SAE 4/5		
	GPS/Maps [%]	V2X [%]	V2V [%]	V2I [%]	V2X [%]
0%	-2	-2	6	6	6
25%	-6	-7	0	-2	-5
50%	-9	-13	-7	-10	-14
75%	-13	-18	-13	-18	-24
100%	-16	-24	-20	-27	-35

#### 4.6.4 Possible effects on LCA

The key parameters possibly affected by autonomous vehicle in an LCA are

- Fuel consumption affecting the operating of the vehicle
- The vehicle size and composition affecting the vehicle manufacturing and
- Lifetime distance travelled affecting per kilometre/miles from manufacturing the vehicle.

Due to the additional necessary equipment of an autonomous vehicle the vehicle mass are increasing and the accessory load. Current estimations for the additional load are between 200 W and 2 kW. The additional mass can also be compensated by lightweight structures, for which

a typical rule of thumb for light weighting is with about 7% energy decrease by 10% mass reduction. The smoother driving might reduce energy consumption by up to 15%.

The longer lifetime distance is quite relevant for the lifetime of the battery and the fuel cell. If the battery and the fuel cell will not last for the longer lifetime, in the LCA the effects of a battery and fuel cell replacement have to be considered.

The ongoing LCA at ARGONNE indicates initially the following possible effects of autonomous vehicles in an LCA (Kelly 2019):

- Mass reduction:
  - Will be important in GHG emission reduction
  - May not offset the impact of automation
  - Could be greater than indicated if safety features are reduced (unlikely near term)
- Increase mileage:
  - Obviously decreases the vehicle manufacturing impact per mile/km
  - May require more maintenance or part replacement that has not been modeled by now (serving to slightly undermine benefits)
- Battery replacement
  - Even 500,000 miles this may not be necessary with large capacity batteries
  - However, replacement does not overwhelm the GHG benefit of BEV
- Automation:
  - At 2 kW power draw these systems represent a serious GHG burden
  - However, technological progress suggests that 200 W may be possible
- Driving smoothing:
  - The effect of smoothing and other like parameters offer significant potential for GHG reduction

#### 4.6.5 Case Study on LCA of autonomous vehicles

Based on the research question “What are the environmental implications of connected and autonomous vehicles (CAVs) an analysis of the GHG implications was performed (De Kleine 2019), which is published as “Life Cycle Assessment of Connected and Automated Vehicles: Sensing and Computing Subsystem and Vehicle Level Effects” (Garon et al. 2018, ES&T).



In [Figure 37](#) the main characteristics of vehicle platform for ICEV and BEV and in the [Figure 38](#) the CAV sensor suite for base case are shown.

The key vehicle burdens considered are

- AV sensors: specs mass and power were collected to calculate production and use phase impacts

- Computing system: NVIDIA Drive PX2 system with higher 2 kW compute load as a sensitivity
- Vehicle weight: increased mass leads to increased fuel consumption
- Aerodynamic drag: fuel economy reduction 0% (small), 0.5% (medium) and 16% (large)

The CAV subsystem causes additional life cycle GHG emissions, as shown in [Figure 39](#), which vary by size and powertrain.

	Base Case	
	BEV	ICEV
		
Model	2015 Ford Focus Electric	2015 Ford Focus
Curb Weight (lb)	3,690	3,055
Combined Fuel Economy (mpg <sub>e</sub> )	107	31
FRV (L <sub>e</sub> / 100 km 100 kg)	0.073	0.27
Production Burden: Energy (MJ)	139,000	101,000
Production Burden: GHGs (kg CO <sub>2</sub> -eq)	10,000	7,200

Results derived from H. C. Kim, et al , "Life Cycle Water Use of Ford Focus Gasoline and Ford Focus Electric Vehicles," J. Ind. Ecol., vol. 20, no. 5, 2016.

**Figure 37:** Main characteristics of vehicle platform for ICEV and BEV (De Kleine 2019)



	Small	Medium	Large
			
Basis	Tesla Model S	Ford Fusion Hybrid	Waymo Pacifica
Cameras	8	7	9
Sonar	12	8	0
Radar	1	2	4
Large LiDAR	0	0	1
Small LiDAR	0	2	4
GPS_INS	1	1	1
DSRC	1	1	1
Computer	2	2	2
Wire Harness	Small	Medium	Large
Structure	Negligible	Small	Large
Maps	Typical Navigation	Typical Navigation	Typical Navigation

Figure 38: CAV sensor suite for base Case (De Kleine 2019)

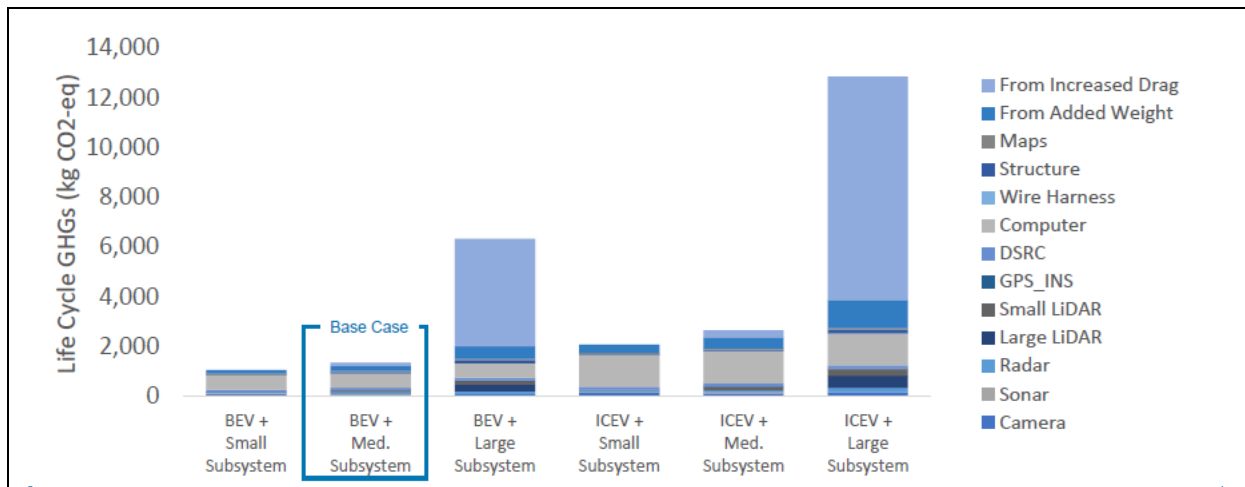

Figure 39: CAV subsystem life cycle GHG emissions (De Kleine 2019)

But CAV systems have positive operational effects, so the combined intrinsic fuel consumption benefit is in average 14% (5 to 22%), which is the combination of

- possible reduction by Eco-driving (7% to 16%), intersection V2V/V2I (2% to 4% and platooning (3 to 5%) and a
- possible increase of faster travel (2 to 8%).

In Figure 40 the baseline scenario for BEV GHG emissions is shown, where the CAV subsystem decrease GHG emissions by 6%. In Figure 41 the vehicle life cycle GHG



emissions over CAV subsystems are shown, where the typical net GHG reduction can be between 6 to 9% compared to non-CAVs, but in worst case a 5% increase is possible.

### Vehicle Life Cycle GHGs Across CAV Subsystems

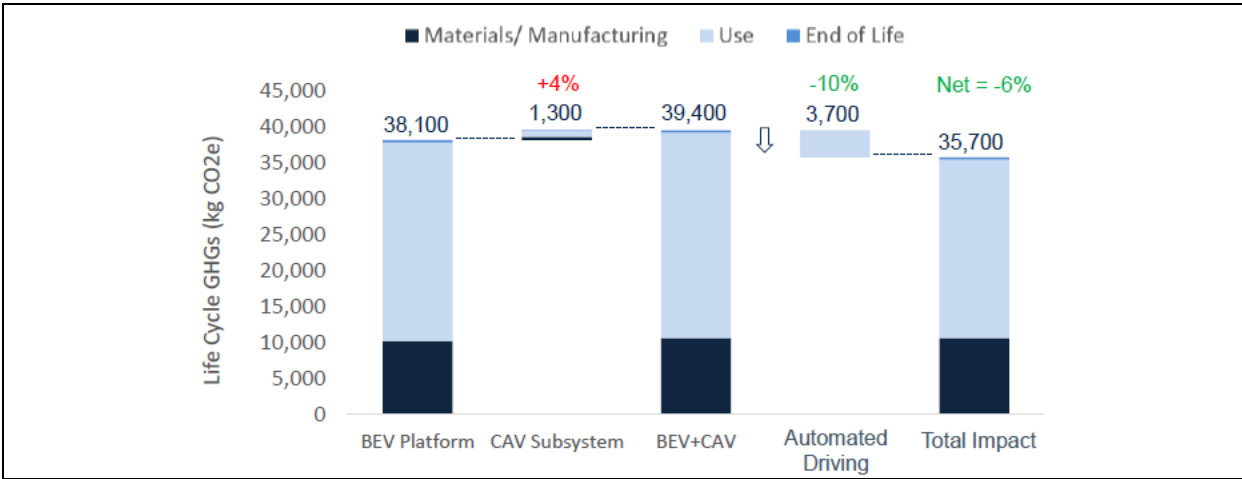

Figure 40: Baseline scenario for BEV GHG emissions (De Kleine 2019)

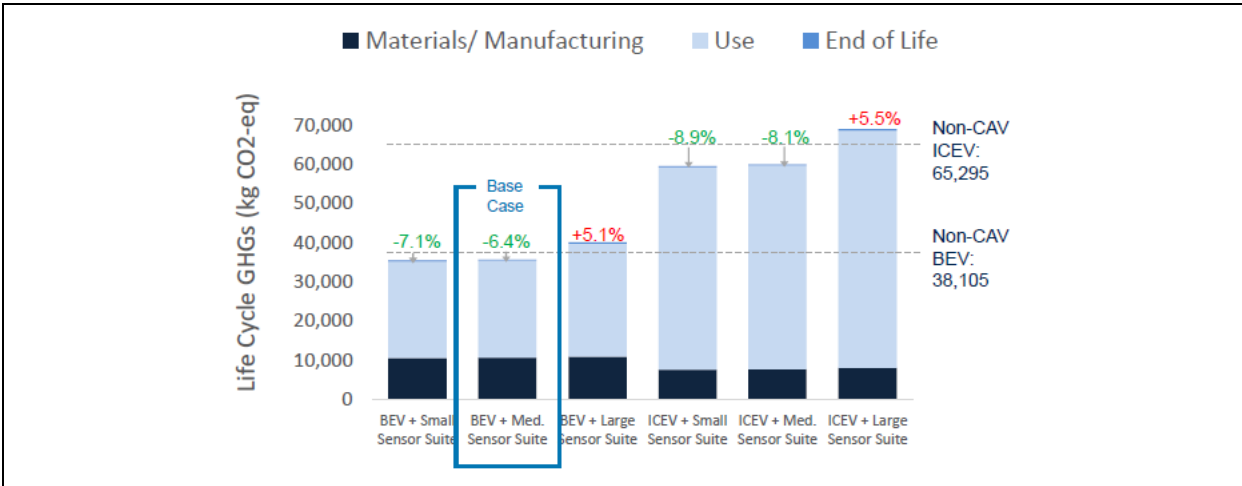

Figure 41: Vehicle life cycle GHG emissions over CAV subsystems (De Kleine 2019)

The main conclusions of this analysis of automated driving are (De Kleine 2019):

- Burden: CAV subsystems increase vehicle life cycle energy and GHG emissions by 3 to 20%
- Benefits: CAV direct effects decrease vehicle energy consumption by an average of 14% (range 5 – to 22%)



- Net impact: vehicle life cycle energy and GHG emissions are impacted – 9% to + 5% compared to non-CAV (assuming average benefit)
- Conclusion: automated driving can contribute to GHG reduction

### 4.7 LCA Case Studies

#### 4.7.1 PHEV real world measuring

Based on on-road measurement the energy consumption and emission of a PEV (Chevy Volt) under real world conditions are measured. The fuel and battery usage of a PHEV under different conditions is shown in [Figure 42](#) and in the [Figure 43](#) the electric driving range. The main conclusions are

- This model of 2016 PHEV did not utilize the engine during summer driving while in EV mode.
- Range far surpassed its rating during the summer.
- During winter, engine was used, and range was reduced.
- Fuel use increased with decreasing ambient temperature
- The modal tailpipe emissions are very low, except during cold/hot starts
- In general, emissions were very low, as expected in electric mode
- Particulate matter was not investigated

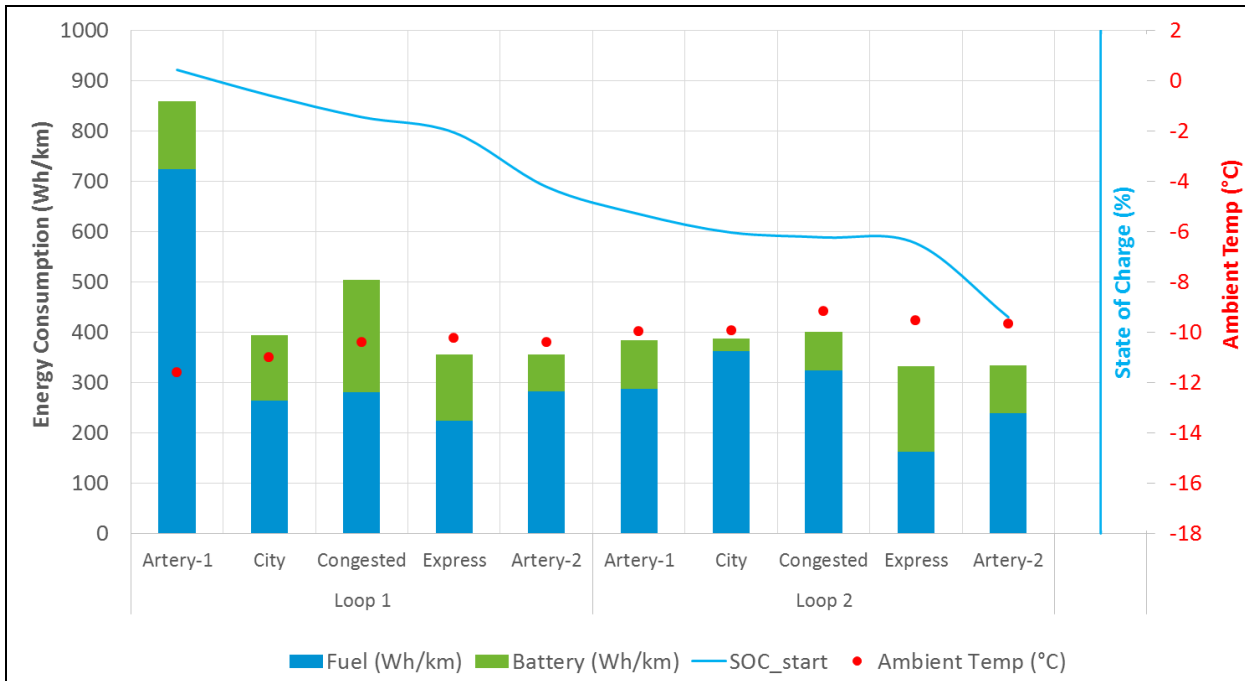

Figure 42: Fuel and battery usage of a PHEV under different conditions (Loiselle-Lapointe 2019)

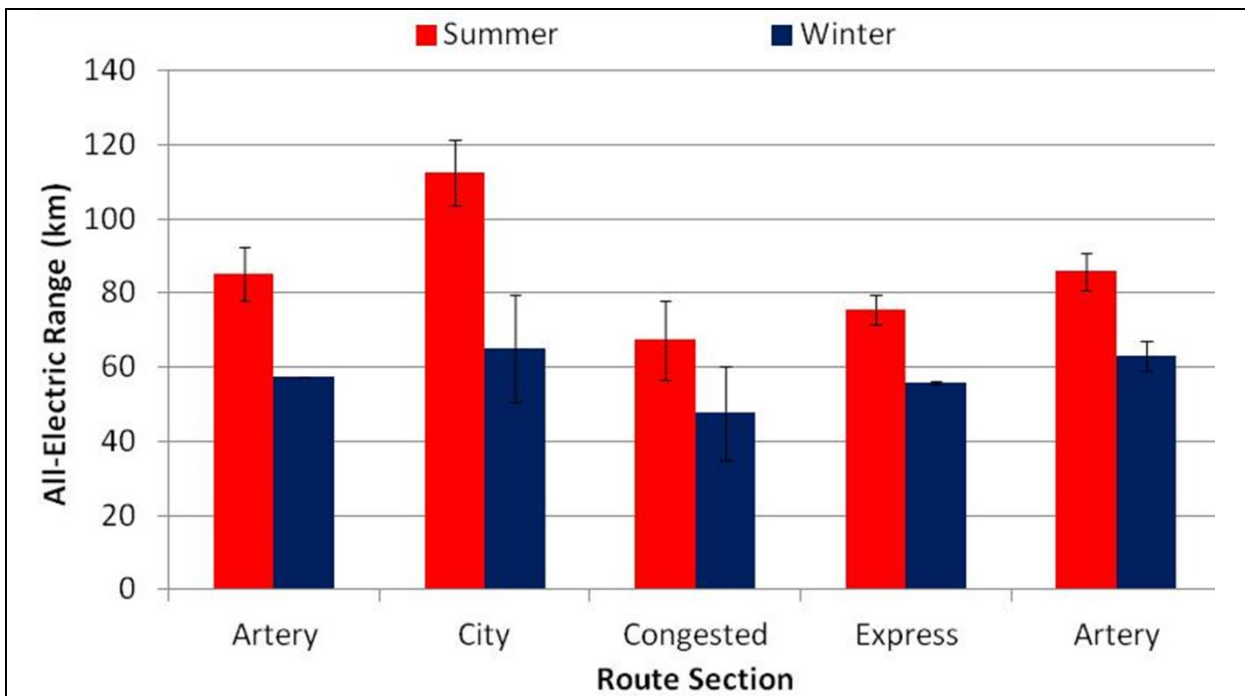

Figure 43: Electric driving range of a PHEV under different conditions (Loiselle-Lapointe 2019)

#### 4.7.2 LCA of Battery and hydrogen fuel cell buses

Based on a LCA the cumulated primary energy demand and the GHG emission of battery electric buses and fuel cell hydrogen buses are calculated and compared to diesel bus. For the battery electric buses two different charging strategies are analysed:

- 1) Opportunity charging (OC) along the route with a smaller battery and
- 2) Depot (overnight) charging (DC) with a bigger battery.

The electricity mix for different countries is analysed including a fictional country “Renewable Republic” (RR), in which only renewable electricity is used. The hydrogen is also produced via electrolysis with this mix. As the buses have different passenger capacities the functional unit is per passenger kilometre capacity. In [Figure 44](#) the GHG emission and in [Figure 45](#) the cumulated primary energy demand are shown. As the hydrogen production and the fuel cell bus are less energy efficient they also have significantly higher GHG emissions and energy consumption. Only in the case of using renewable electricity the GHG emission of the hydrogen bus are similar to the GHG emission of the DC bus, as the current battery production is still quite GHG intensive. But the cumulated primary energy demand of the hydrogen fuel cell bus is more than double compared to the battery electric buses and even higher than the diesel bus.

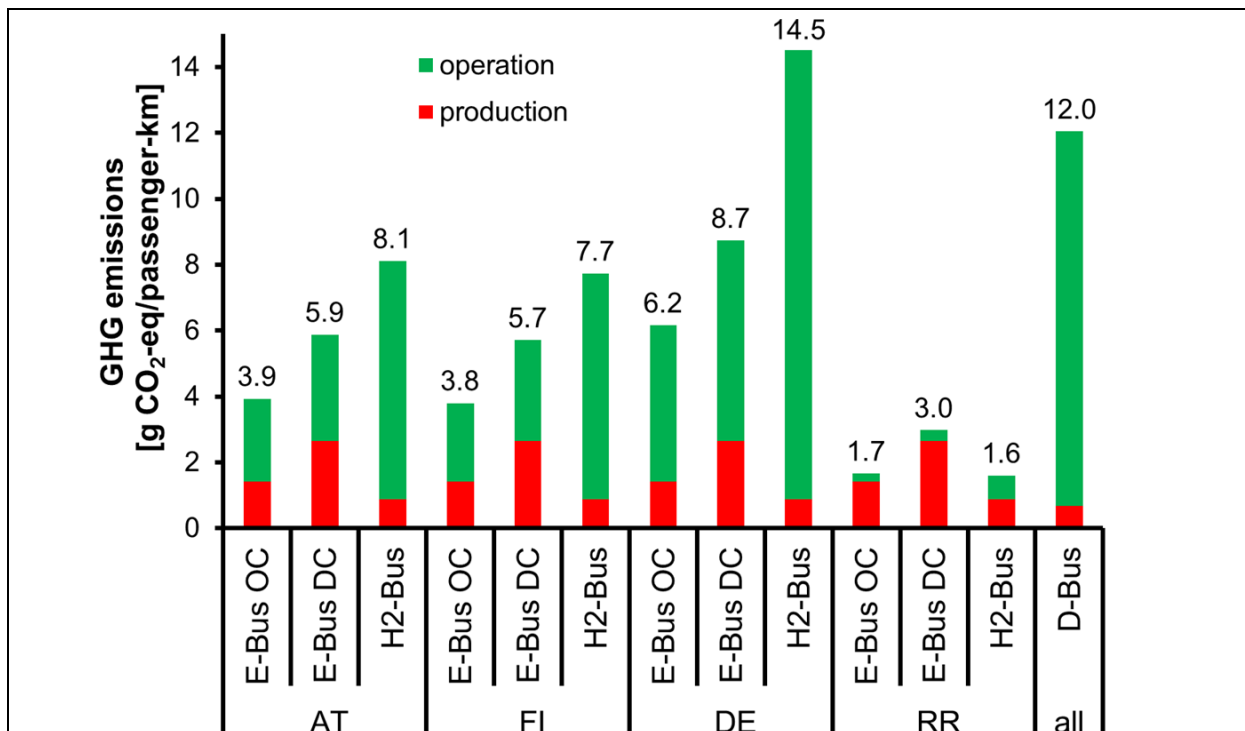

Figure 44: GHG emission of battery and fuel cell buses compared to diesel bus (Jungmeier 2019)

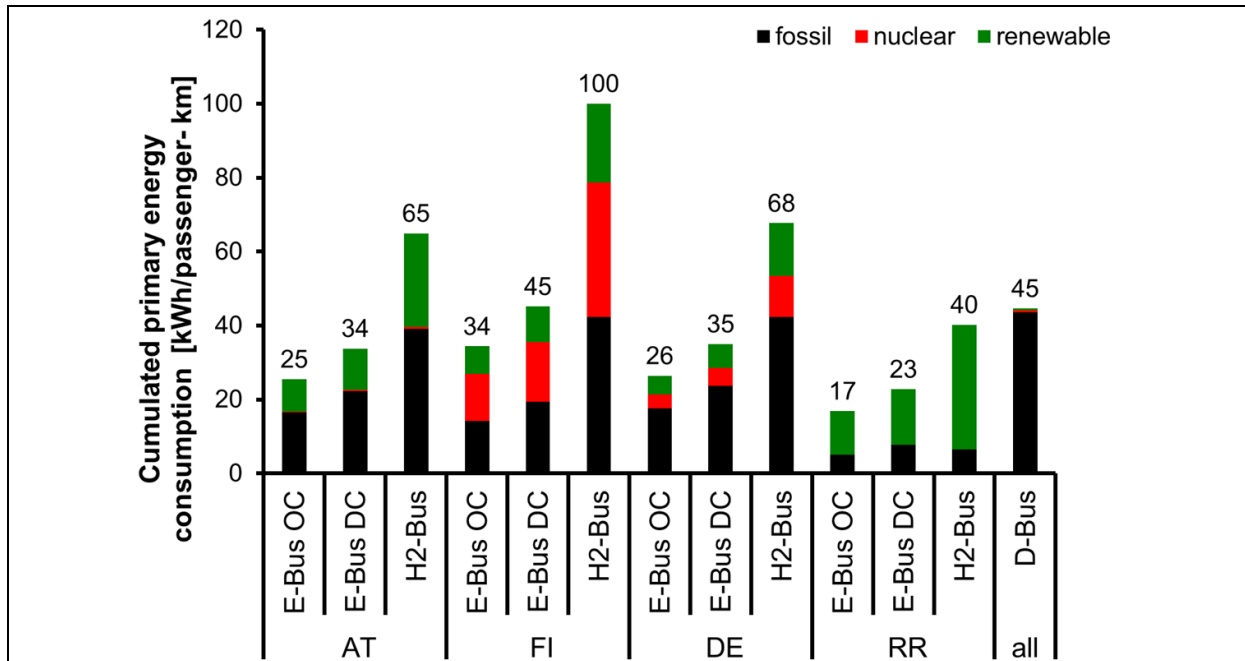

Figure 45: Cumulated primary energy demand of battery and fuel cell buses compared to diesel bus (Jungmeier 2019)

The following conclusions are made:

- 1) Current production of batteries substantially contribute to GHG emissions and primary energy demand in LCA of electric vehicles
- 2) Electricity mix has strong influence on environmental benefits of electric bus
- 3) Opportunity charging lower GHG emissions&energy demand than depot charging due to smaller battery&electricity consumption
- 4) Main influences: energy demand for driving, heating&cooling, lifetime of battery&bus, annual kilometres
- 5) Hydrogen busses higher GHG emissions and primary energy demand than electric bus
- 6) Is this a fair comparison? Or do we need to apply LCA to whole bus fleets?

#### 4.8 Identification of key issues

In group work the key issues on

- 1) Land Use – Resources – Waste in LCA of EVs and
- 2) LCA of Autonomous Vehicles

were identified and documented in a mind map.

#### 4.8.1 Land Use – Resources – Waste in LCA of EVs

On “land use” the following key issues are identified:

- **Land transformation [m2]**
    - Land use archetypes
      - From
      - To
      - Extraction
        - Minerals
          - Mined area
          - Deposits
            - Tailings
            - Overburden
        - Fossil fuels
      - Renewable energy
        - Biomass
        - Windpower
        - Solar farms
        - Hydro reservoirs
      - Grid infrastructure
      - Road infrastructure
- **Land occupation [m2\*a]**
  - Duration of occupation
- **Ecosystem services**
  - Soil functions
    - LANCA
      - From
      - To
      - After
    - SOM/SOC
    - Biodiversity

On “abiotic resources” the following key issues are identified:

- **Mineral**
  - Battery
    - NMC/NCA
      - Ni
      - Co
      - Li
      - Mn
      - Al
    - LFP
      - Li
      - Fe
      - P
    - Fuel cell
      - Pt
    - Electric motor
      - Nd
      - Dy
    - Power electronics
      - Cu
      - Au
      - Pt
- **Fossil fuels**
- **Resource criticality**
  - Complementary to LCA
  - Requires more and different data
- **Resource depletion not a primary environmental concern**
  - Supply risks
  - Price effects
  - Substitutability
- **Virgin**
- **Recycled**

- **No consensus on impact assessment methodology in LCA**

On “waste” the following key issues are identified:

- **Reuse**
  - Battery
    - Traction
    - Stationary
  - Magnets
- **Recycling**
  - Production waste
    - Raw materials
  - End-of-Life
    - Battery
      - Hydro
        - recover Li
        - Li(OH)
        - CoSO<sub>4</sub>
        - NiSO<sub>4</sub>
        - housing material
        - electrolyte
      - pyro
        - slag
          - Li
          - Al
        - Co
        - N
        - Mn
      - direct (bench scale)
        - cathode material

In [Figure 46](#) the mind map on “Land Use – Resources – Waste in LCA of EVs”



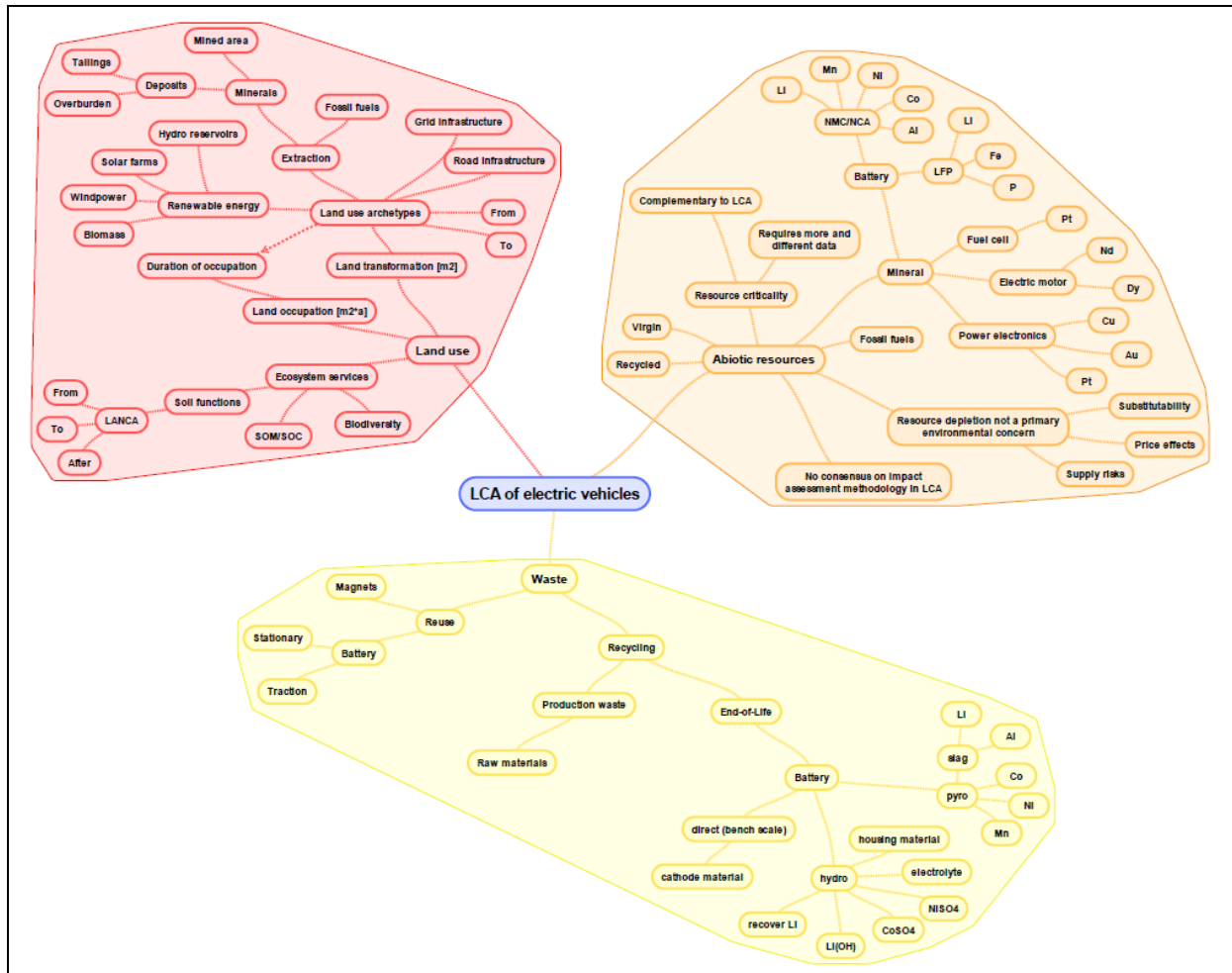

Figure 46: Mind map on “Land Use – Resources – Waste in LCA of EVs”

#### 4.8.2 LCA of Autonomous Vehicles

The 5 main areas of LCA of autonomous vehicles are

- Vehicle level
- Operating conditions
- Behaviour
- Infrastructure and
- System level.

On “vehicle level” the following key issues are identified:

- **Energy/fuel consumption**
- **Hardware**

- Mechanical
  - Housing
  - Structure/frame
  - Cooling
- Electronic
  - Sensors
  - Computation
  - Actuators
  - GPS
  - Data transfer
- **Drivetrain**
  - ICE
  - BEV
  - PHEV
  - FCEV
  - HEV
- **Vehicle mass changes**
- **Level of automation**
- **Aerodynamic drag**
- **Vehicle class**
- **Safety features**
- **Charging strategy**
- **Performance attributes**
- **Battery life expectancy**
- **Vehicle lifetime mileage**

On “system level” the following key issues are identified:

- **Rebound effect**
  - Increased urban sprawling
  - Higher average speeds
  - More travel demand
- **Mode shifts**
  - Away from better modes
  - In combination with other modes

- **Ride sharing**
  - Empty miles
- **Congestion**
  - Less
  - More
- **Ride smoothing**
- **Platooning**

On “operating conditions” the following key issues are identified:

- **Climate**
- **Fleet composition**
- **Driving cycles**
- **Road types**

On “behaviour” the following key issues are identified:

- **User acceptance**
  - Purchase
  - Opt-out
  - Utilization
- **User misuse**

On “infrastructure” the following key issues are identified:

- **V2I/V2V (vehicle to infrastructure/vehicle to vehicle)**
- **Sensors**
- **Data volume**
- **Energy consumption**
  - Local
  - Network
- **Traffic lights**
- **Parking space**

In [Figure 47](#) the mind map on “LCA of Autonomous Vehicles” is shown.

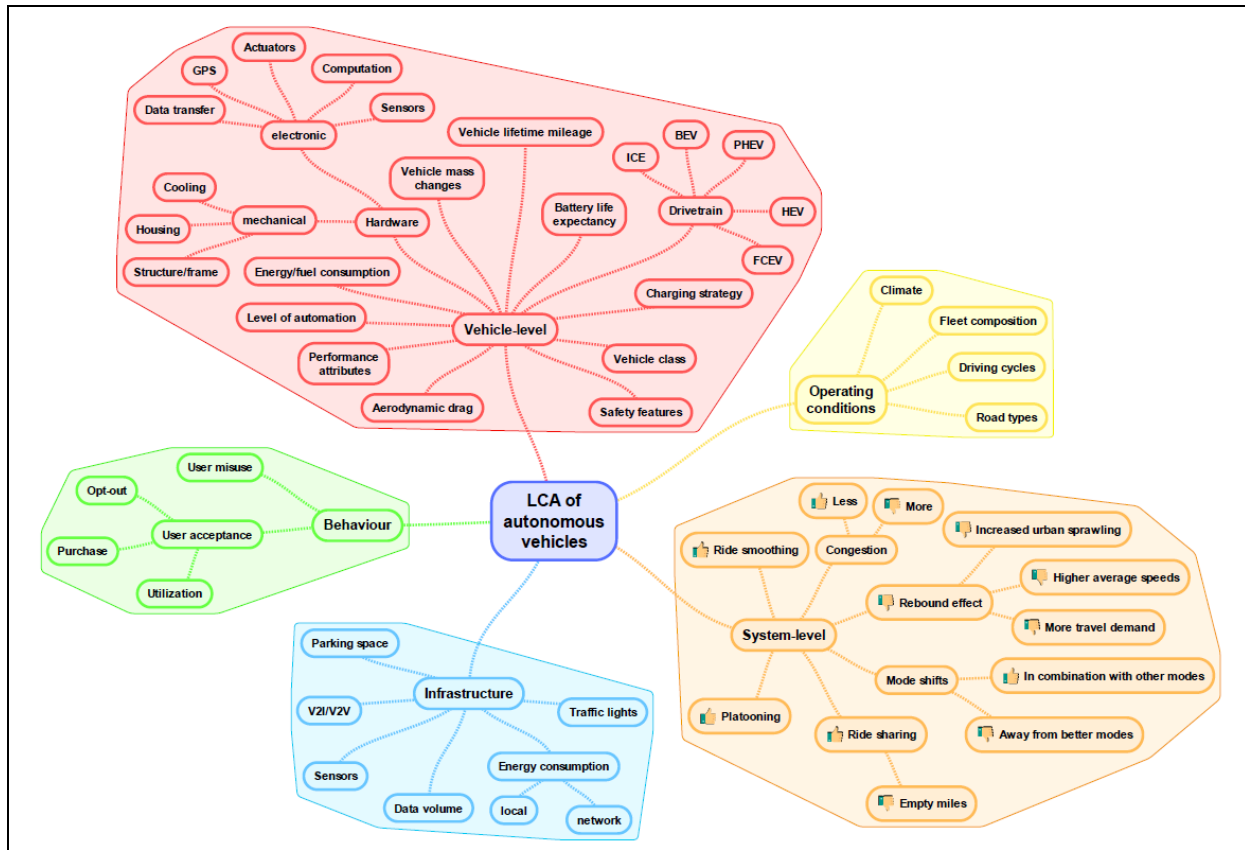

Figure 47: Mind map on “LCA of Autonomous Vehicles”

## 5 Information on Task 30 “Assessment of Environmental Effects of Electric Vehicles”

**Members:** Austria, Canada, Germany, Spain, South Korea, Turkey, USA

Electric vehicles have the potential to substitute for conventional vehicles to contribute to the sustainable development of the transportation sector worldwide, for example, in the reduction of greenhouse gas (GHG) and particle emissions. There is international consensus that the improvement of the sustainability of electric vehicles can only be analyzed on the basis of life cycle assessment (LCA), which includes the production, operation, and the end-of-life treatment of the vehicles and the fuel cycle. All environmental impacts must include the whole value chain and - if relevant - interactions from recycling in the dismantling phase to the production phase, if recycled material is used to produce new vehicles.

The aim of Task 30 (2016 – 2020) is to analyze and assess environmental effects of electric vehicles (EVs) on water, land use, resources and air based on life cycle assessment in a cooperation of the participating countries in the International Energy Agency (IEA).

Task 30 is using the results of the completed Task 19 “Life Cycle Assessment of Electric Vehicles” (2011 – 2015, [www.ieahev.org/tasks/task-19-life-cycle-assessment-of-evs/](http://www.ieahev.org/tasks/task-19-life-cycle-assessment-of-evs/), led by

JOANNEUM RESEARCH) as a foundation to subsequently examine the environmental effects – benefits and impacts - of vehicles with an electric drivetrain (EVs), based on life cycle assessment (LCA). With an eye on the three phases of LCA, such as production, operation and dismantling of EVs, various environmental effects of EVs on water, land use, resources and air, among others, will be analyzed and assessed. Thereby a strong accent is put on the comparison of environmental effects between pure battery EVs (BEV) and Plug-in hybrids (PHEVs) on one hand and conventional ICE vehicles using gasoline and diesel on the other side.

In recent years the focus in environmental assessments of electric vehicles was on global warming and primary energy consumption. But now it is recognized that other impacts gain additional relevance and must be addressed by life cycle based comparisons like water, land use, resource consumption, local PM and NO<sub>x</sub>-emissions. Therefore Task 30 will focus on following topics covering methodologies, data and case studies:

- Effects of EVs on water (emissions to water, waste water, “Water Footprint” of EVs)
- Effects on EVs on land use-resources-waste (land use, occupation and degradation, demand of renewable and fossil resources, recycling)
- Effects on EVs on air (local emissions and effects of NO<sub>x</sub>, PM and C<sub>x</sub>H<sub>y</sub>, human health effect and non-energy related emissions from tires and brakes)
- Overall environmental effects and their assessment (comparing and assessing different impact categories, single score methodologies, stakeholder involvement).

Within the Task, methodologies for helping countries implement EVs by identifying possibilities to maximize the environmental benefits will be developed. Besides, various case studies will be analyzed and networking combined with information exchange will be supported within the Task’s frames (Figure 48). The Task will proceed by holding a series of expert workshops addressing the following objectives:

- Methodologies on assessment of environmental effects
- Analyses of necessary and available data
- Overview of international studies/literature
- Analyses of current knowledge and future challenges
- Overview of key actors and stakeholders and their involvement
- Communication strategies to stakeholders
- Summarizing further R&D demand

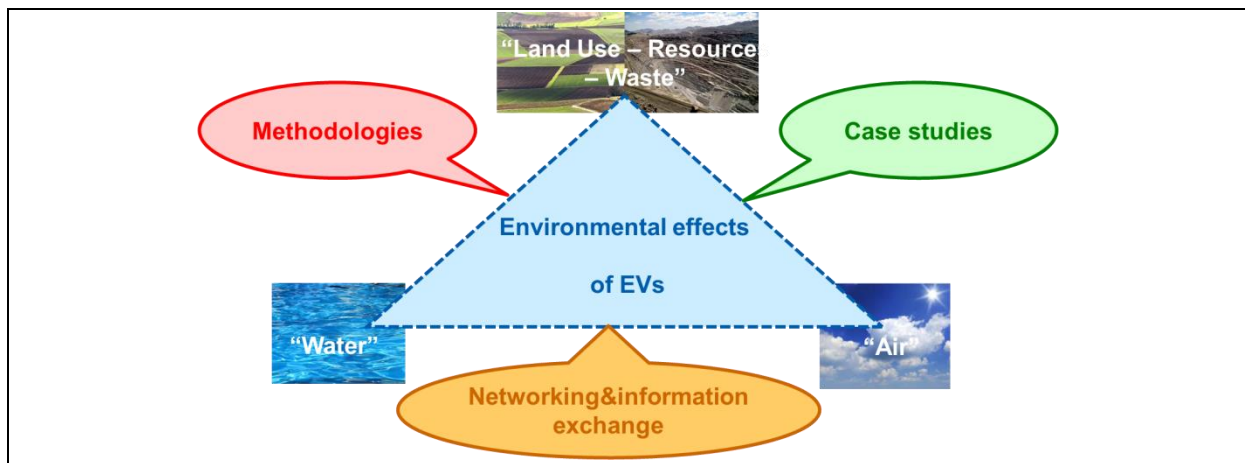

**Figure 48:** Working method in Task 30

Members in this Task will compile a list of environmental benefits and impacts of EVs with the goal to increase their overall acceptance by providing facts and figures on the environmental effects of EVs. Thus, numerous advantages of EVs compared to conventional vehicles will be shown. These results should help the industry and government to support further development and employment of EVs in all transport modes. The results will document and summarize the state of current knowledge and future challenges (incl. methodologies and case studies) on

- Effects of electric vehicles on water
- Effects of electric vehicles on Land use – resources – waste
- Effects of electric vehicles on air
- Overall environmental effects and their assessment of EVs
- R&D demand.

In addition to these technical and scientific results a glossary on “Frequently asked questions” (FAQ), a framework for Communication strategies to stakeholders and dissemination activities (e.g. proceedings, reports, papers, notes, presentations) will be available.

**Contact Details of the Operating Agents**

For further information, please contact the Task 30 Operating Agent:

**Dr. Gerfried Jungmeier**

JOANNEUM RESEARCH Forschungsgesellschaft mbH

LIFE – Centre for Climate, Energy and Society

Waagner-Biro-Strasse 100

A-8020 Graz, Austria

[gerfried.jungmeier@joanneum.at](mailto:gerfried.jungmeier@joanneum.at)

+43 316 876 7630



**Deidre Wolff**

IREC – Catalonia Institute for Energy Research

Jardins de les Dones de Negre, 1 2<sup>a</sup>PI

Sant Adrià de Besòs 08930

[dWolff@irec.cat](mailto:dWolff@irec.cat)

+34 933 562 615

[www.ieahev.org/tasks/task-30-assessment-of-environmental-effects-of-electric-vehicles/](http://www.ieahev.org/tasks/task-30-assessment-of-environmental-effects-of-electric-vehicles/)



## Annex 4: Expert Workshop on Impact Assessment



## **Overall Assessment in LCA of Electric Vehicles**

-

## **From Inventory Analysis to Impacts of Electric Vehicles**

*Online Expert Workshop*

**October 13 – 14, 2021**

**Organised and moderated by:**



Shaping Energy for a Sustainable Future

Gabriela Benveniste Pérez (gbenveniste@irec.cat)

Víctor José Ferreira Ferreira (vjferreira@irec.cat)

**Content**

**Content**

1	Summary.....	4
1.1	Introduction .....	4
1.2	Impact assessment .....	4
1.3	Identification of mid- and endpoint indicators.....	5
1.4	Brief description of indicators .....	6
1.4.1	Mid-point indicators .....	6
1.4.2	End-point indicators.....	8
1.5	Assessment methodologies for local and regional impacts.....	9
1.5.1	Human Toxicity Potential.....	9
1.5.2	Abiotic Depletion Potential.....	10
1.5.3	Water .....	10
1.5.4	Biodiversity.....	11
1.6	Recommendations .....	12
1.6.1	Selection of indicators in LCA for EVs and ICEs.....	12
1.6.2	Framework .....	12
1.6.3	Current minimum requirements .....	13
1.6.4	Future advanced requirements.....	14
1.7	Conclusion and outlook .....	14
2	Introduction .....	16
3	Aim of the workshop.....	17
4	Programm .....	18
5	Results.....	20
5.1	LCA of EV and ICE - Human Toxicity Potential, Abiotic Resource Depletion and Water- Scarcity .....	20
5.2	Assessment Concept of Protection Areas - Human Health, Natural Resources and Natural Environment .....	26
5.3	LCA of Passenger Vehicles - Impacts Beyond Climate Change .....	33
5.4	LCA of Electricity in Europe to 2050 - Beyond GHG and Primary Energy.....	35
5.5	Overview of the Commonly Used LCIA and LCI indicators in the Automotive LCA Studies in North America- Status-quo, Limitations and Future Perspective.....	36
5.6	Benefits of Vehicle Electrification - GHG Emission of Vehicle Charging .....	40
5.7	Life Cycle Analysis of a Modular Vehicle Concept: Insights in the Methodological Approach and Initial Results .....	40
5.8	Dynamic LCA for BEV Introduction and Development of Vehicle Fleet in Austria 2010 to 2050.....	40

5.9 Cradle to Grave Lifecycle GHG and Cost Analysis of Current and Future Light Duty Vehicles in the United States .....41

5.10 TRACI\*): Current Status and Future Directions .....41

5.11 Identification of key issues on Impact Assessment (interactive group work) .....46

    5.11.1 What do you think are the most appropriate impact categories and assessment methodologies for EVs environmental analysis?.....46

    5.11.2 In your opinion, which are the most relevant impacts to assess for comparing EVs and ICEs? .....47

    5.11.3 Group 1: Selection of Impact Categories and Assessment Methodologies .....48

    5.11.4 Group 2: Most Relevant Impacts for Comparing EVs and ICE .....49

6 Task 30 “Assessment of Environmental Effects of Electric Vehicles” .....52

## 1 Summary

### 1.1 Introduction

Life Cycle Assessment (LCA) is a methodology to estimate environmental effects of a product or service along the whole life cycle – from production, use and end of life treatment. There is an international consensus that the environmental effects can only be analysed and assessed on the basis of LCA.

The Task 30 “Assessment of Environmental Effects of Electric Vehicles” (2016 – 2022) in the Technology Collaboration Program (TCP) of the International Energy Agency (IEA) works on the LCA of electric vehicles in comparison to vehicles using fossil and renewable fuels.

The four phase of an LCA (according to ISO 14,044) are

- 1) Goal and Scope Definition
- 2) Inventory analysis
- 3) Impact Assessment and
- 4) interpretation.

The focus of the expert workshop of Task 30 (virtually hosted by IREC, Spain, October 13&14, 2021) was to analyse and assess different Impact Assessment methodologies of battery electric vehicles (BEV) and conventional vehicles with an internal combustion engine (ICE). Based on the inventory analysis of elementary and physical flows in the Life Cycle Assessment (LCA) different impact categories beyond global warming and primary energy consumption are relevant. The way from Inventory Analysis to Impact Assessment is via mid- and end-point indicators.

In the workshop the status, the future perspectives and limitations of the Impact Assessment and its impact categories relevant for LCA of vehicles were presented by LCA experts and discussed within the participants.

The result is the summary statement on the status of Impact Assessment methodologies and its future perspectives for electric and conventional vehicles.

### 1.2 Impact assessment

In the Figure the procedure from Inventory Analysis to the Impact Assessment in LCA is shown, where in step 1 the mid-point indicators and in step 2 the possible end-point indicators are assessed. In step 1 and step 2 the different impact assessment methodologies are applied.

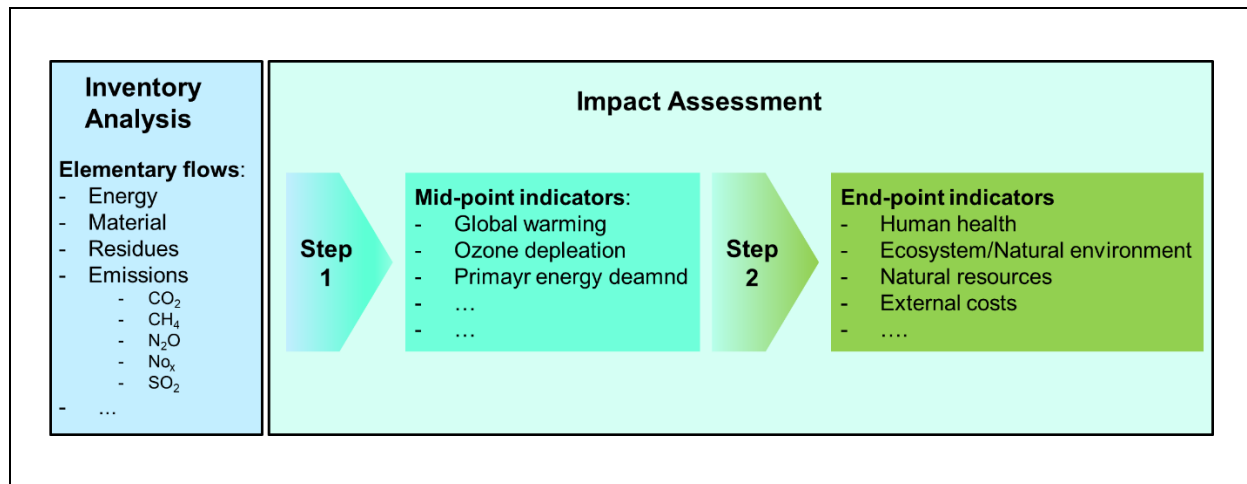

Figure: From Inventory Analysis to the Impact Assessment in LCA

### 1.3 Identification of mid- and endpoint indicators

Within the workshop the different mid- and end-point indicators with their assessment methodology were presented and discussed.

With regard to the geographical scope of the different impacts the mid-point indicators are grouped for global, regional and local impacts. The mid-point indicators on these geographical scopes collected in the workshop were

- Global
  - Climate change
  - Ozone depletion
  - Primary energy use (consumption) (fossil and renewable)
  - Resource use, minerals and metals
  - Water footprint (based on inventory level method)
  - Land use (focus on inventory data)
- Regional
  - Acidification
  - Photochemical ozone formation
  - Smog formation
  - Eutrophication, terrestrial
  - Eutrophication, freshwater
  - Eutrophication, marine
  - Ionising radiation
- Local
  - Human toxicity, cancer
  - Human toxicity, non-cancer

- Particulate matter
- Land use
- Water scarcity
- Biodiversity
- Ecotoxicity, fresh water aquatic
- Ecotoxicity, marine aquatic
- Ecotoxicity, terrestrial

Water and land use were allocated to the global and also to the regional level, whereas on global level mainly results from inventory analysis are relevant, whereas on local level a very distinctive methodology might be applied for local impact assessment based on very localized data.

The end-point indicators, which are always assessed on global scale, collected in the workshop are

- Protection areas
  - Human health
  - Ecosystem health
  - Resource availability
- External costs.

## 1.4 Brief description of indicators

A distinction between mid- and end-point indicators is made.

### 1.4.1 Mid-point indicators

The brief description of global mid-point indicators are:

- Climate change:
  - Radiative forcing as global warming potential - GWP 100 (kg CO<sub>2</sub>-eq) Global Warming Potential kg CO<sub>2</sub>-eq
  - Increase in the average global temperature resulting from greenhouse gas emissions
- Ozone depletion:
  - Ozone depletion potential – ODP (kg CFC-11-eq)
  - Depletion of the stratospheric ozone layer protecting from hazardous ultraviolet radiation
- Primary energy use (consumption) (fossil and renewable):
  - Use of fossil, renewable and nuclear primary energy resources (MJ)
  - Depletion/use of energy resources and deprivation for future generations
- Resource use minerals and metals:



- Abiotic resource depletion – ADP ultimate reserves (kg Sb-eq)
- Depletion of mineral and metal resources and deprivation for future generation
- Water footprint:
  - Amount of water consumed (m<sup>3</sup>)
  - Amount and type of water used
- Land use:
  - Occupied land (m<sup>2</sup>)
  - Amount and type of land occupied over a certain time.
  - Amount and type of land transformed

The brief description of regional mid-point indicators are:

- Acidification:
  - Accumulated Exceedance - AE (mol H<sup>+</sup> eq) or kg SO<sub>2</sub>-eq
  - Acidification from air, water and soil emissions (primarily sulphur components) mainly due to combustion
- Photochemical ozone formation, human health:
  - Tropospheric ozone concentration increase (kg NMVOC eq (ethen –eq C<sub>2</sub>H<sub>4</sub>-eq)
  - Potential of harmful tropospheric ozone formation (“summer smog”) from air emissions
- Smog formation
  - Formation of intensive air pollution with decreasing visibility deriving from combustion processes
  - Potential of smog formation (“winter smog”) from air emissions
- Eutrophication, terrestrial
  - Accumulated exceedance – AE (mol N eq)
  - Eutrophication and potential terrestrial impact caused by nitrogen and phosphorus emissions mainly due to fertilizer, combustion, sewage systems
- Eutrophication, freshwater
  - Fraction of nutrients reaching freshwater end compartments (kg N eq)
  - Eutrophication and potential freshwater impact caused by nitrogen and phosphorus emissions mainly due to fertilizer, combustion, sewage systems
- Eutrophication, marine
  - Fraction of nutrients reaching marine end compartments (kg N eq)
  - Eutrophication and potential marine impact caused by nitrogen and phosphorus emissions mainly due to fertilizer, combustion, sewage systems
- Ionising radiation, human health
  - Human exposure efficiency relative to U – 235 (kBq U-235 eq)

- Impact of exposure to ionising radiation on human health

The brief description of local mid-point indicators are:

- Human toxicity, cancer
  - Comparative toxic unit for humans on cancer (CTUh)
  - Potential impacts on human health via ingestion and inhalation routes. Contact and direct exposure not considered
- Human toxicity, non-cancer
  - Comparative toxic unit for humans on non-cancer (CTUh)
  - Potential impacts on human health via ingestion and inhalation routes. Contact and direct exposure not considered
- Particulate matter
  - Impact on human health (disease incident)
  - Impact on human health caused by particulate matter emissions and its precursors (e.g. sulphur and nitrogen oxides)
- Land use
  - Soil quality index, representing the aggregated impact of land use on: biotic production, erosion resistance, mechanical filtration, groundwater replenishment
  - Transformation and use of land for agriculture, roads, housing, mining or other purposes. The impact can include loss of species, organic matter, soil filtration capacity, permeability
- Water scarcity
  - Weighted user deprivation potential (m<sup>3</sup> world eq)
  - Depletion of available water depending on local water scarcity and water needs for human activities and ecosystem integrity
- Biodiversity
  - Impacts on biodiversity
  - Various methods under development that can be operable and in line with current life cycle inventory phase

Additional also Ecotoxicity is a regional impact, which could be an aspect of water and land use as well as biodiversity. Ecotoxicity might be subdivided in

- fresh water aquatic
- marine aquatic
- terrestrial

#### 1.4.2 End-point indicators

The discussed possible end-point indicators are

- Protection areas and

- External costs

The Protection areas are split in

- Human health, which is measured in DALYs - Disability-Adjusted Life Years or Disease-Adjusted Life Years caused by the various impacts  
Ecosystem health which is measured in PDFm2yr Potentially Disappeared Fraction of species per square meter per year caused by the various impacts
- Resource availability, which is measured in MJ, covering mainly primary energy resources

The External costs are measured in € (or \$). The external cost assess the damage costs caused by the various impacts, e.g. on human health, ecosystem and infrastructure. Main damage costs caused by Climate change impacts, Regional air pollution and Land use.

## 1.5 Assessment methodologies for local and regional impacts

The following most relevant assessment methodologies for regional and local impacts were identified.

### 1.5.1 Human Toxicity Potential

The Human Toxicity Potential (HTP) is a measure of the impacts on human health. The characterisation factors describe the fate, exposure and effects of toxic substances over an infinite time horizon.

Since 2005 a comprehensive comparison of the existing methods was initiated by the UNEP-SETAC Life Cycle Initiative. The consensus model USEtox is now recommended as the “best” available method by UNEP-SETAC (<http://usetox.org>), and also recommended by EC-JRC for Product Environmental Footprints for human toxicity potential. In USEtox, a distinction is made between “interim” and “recommended” characterisation factors (CF). This reflects the different level of reliability of the calculations. CFs for metals are classified as “interim” due to high uncertainty on fate and exposure:

- The mid-point CFs units for HTP are in “Comparative Toxic Unit for Human Health” (CTUh), which estimates the increase in morbidity in the total human population per unit mass of a chemical emitted (i.e., cases per kilogram). Separate “cancer” and “non-cancer” CTUh are provided, but both have default equal weighting, in lack of more precise insights
- End-point CFs is “Disability-Adjusted Life Years” or “Disease-Adjusted Life Years” (DALY), taking into account the years lost to premature death and expressing the reduced quality of life due to illness in years as well, are also optionally provided, but these entail further assumptions and uncertainty, and are not ISO-compliant for all “comparative assertions intended for public disclosure” (ISO 14,044).

Another methodology develop for Human Health, e.g. particulate potential (HHPP) is TRACI - Tool for the Reduction and Assessment of Chemical and other environmental Impacts (<https://www.epa.gov/chemical-research/tool-reduction-and-assessment-chemicals-and-other-environmental-impacts-traci>)

### 1.5.2 Abiotic Depletion Potential

The Abiotic Depletion Potential - Minerals & Metals (ADP\_MM) concerns the extraction of scarce minerals. Values are determined for each extraction of minerals based on the remaining reserves and rate of extraction. AD methods mainly differ in terms of time horizon (e.g., focus on long-term depletion potential vs. short-term supply risk), and associated assumptions on reserve bases:

- The CML ADP<sub>ultimate reserves</sub> uses current extraction rates and assumes stock estimates = total crustal contents
  - Total crustal content is chosen as the best available proxy for “ultimately extractable” reserve, since the latter is a moving target that depends on unknown future technological developments
  - Mid-point CFs are expressed in terms of kg Antimony equivalent (Sb-equivalent)
  - Method originally developed in 1995, then CFs updated in 2002 and 2019.
  - This method is “recommended” by UNEP/SETAC Life Cycle Initiative, and by EC-JRC
- ADP<sub>economic reserves</sub> alternatively assumes stock estimates, those that are economically extractable at present
  - Mid-point CFs are still expressed in terms of kg(Sb-equivalent).
  - This method better highlights the more imminent pressure on resource availability
  - But, it suffers from two main weaknesses:
    - Anthropogenic stocks (e.g., secondary sources) are excluded
    - Economic reserve estimates tend to increase over time, leading to potential underestimation of depletion threat
  - This method is only “suggested” but not officially “recommended” (a much weaker endorsement)

### 1.5.3 Water

To assess water related impacts two main methodologies are relevant:

- Water Footprint and
- Water Scarcity

The Water Footprint Standard is an inventory-level method (<https://waterfootprint.org/en/resources/publications/water-footprint-assessment-manual-global-standard/>).

In the Water Footprint the water withdrawal is analysed and classified in:

- off stream water use
  - Consumptive use and
    - Green water: evaporative from crops/forestry

- Blue water: non-evaporative run-off
- Grey water: additional water required to dilute pollutants to water quality standards
  - Degradative use, released as polluted water
  - in stream water use, released as unpolluted water

For Water Scarcity there are two impact assessment methodologies

- Water Stress Index (WSI) and
- Available Water Remaining(AWARE)

The main aspects of these two impact assessment methodologies are:

- Water Stress Index (WSI)
  - Water stress index is typically defined as the relationship between total water use and water availability. The closer water use is to water supply, the more likely stress will occur in natural and human systems.
  - Regionalised mid-point characterization model based on withdrawal-to-availability ratio
  - WSI indicates the portion of  $WU_{consumptive}$  that deprives other users of freshwater
  - Further converted to end-point indicators for Ecosystem Quality (EQ) and Human Health (HH), the latter based on competition with irrigation
  - This indicator has been used by the United Nations and others.
- Available Water Remaining (AWaRe)
  - Regionalised mid-point characterization model based on withdrawal-to-availability ratio
  - New consensus method of UNEP/SETAC working group on water use in LCA (WULCA)
  - Suggested by EC-JRC as new standard impact assessment method for water use in PEF
  - WaterS is an indicator from the AWARE characterisation model that provides an assessment for water consumption. Units for scarcity-adjusted water use are in  $m^3$  world eq

#### 1.5.4 Biodiversity

Biodiversity is also much related to land use aspects. The impact assessment methodologies are therefore very complex and still under development e.g.:

- Ongoing efforts of the JRC within dedicated working groups.
- JRC is exploring LCIA methods and approaches addressing impact on biodiversity to be potentially integrated in the EF method in the future
- Currently, operational and novel methods addressing impact on biodiversity at the midpoint and endpoint (that take into account different midpoint impacts such as Climate Change, Land Use, etc.) are under test by the JRC

- Key aspect is to judge how these methods can be operable and in line with current inventory phase

## 1.6 Recommendations

### 1.6.1 Selection of indicators in LCA for EVs and ICEs

Life Cycle Assessment is a method to analyse and assess a system from cradle to grave for product and services. So LCA as a system assessment method addresses environmental impacts best on global scale like global warming or resource use. The assessment of regional and local environmental impacts like acidification, human toxicity and biodiversity are depending very much site-specific local conditions. So an inclusion of regional and local impact categories needs a very site-specific inventory in LCA, e.g. in combination with GIS (Geographical information System).

Due to the high need of site-specific data and/or lacking of these data, the regional and local impacts are very difficult to be addressed in practice by LCA or EVs and conventional ICEs today. So further essential developments are needed to cover these impacts in future.

Otherwise it is also argued that other methodologies than LCA can address these regional and local environmental impact better; e.g. biodiversity is mainly relevant in agricultural and forestry systems, human toxicity is relevant for quality of life and living conditions.

Due to the methodological complexity and uncertainty the practical addressing and calculation of “end point indicators” is not recommend for LCA of electric vehicles and conventional vehicles.

The main relevant impacts with current state of impact assessment methodologies using available and robust inventory data in LCA are mainly for global impact categories.

These main global impact categories for transportation systems are:

- Climate change
- Primary energy use (consumption) (fossil and renewable)
- Resource use minerals and metals
- Water footprint (inventory level)
- Ozone depletion
- Land use (inventory level)

### 1.6.2 Framework

Taking these six identified global impacts for EVs into account, there are some recommendations concluded for current and future LCA practical application.

The recommendations are split into

- current minimum requirements and
- future advanced requirements

for global impact assessment of EVs in comparison to other vehicles.

For all considered impacts of course the goal and scope of the LCA is essential.



The results on the considered global impact categories should be documented and communicated not only for the total value but also for the three main phases in the life cycle of a transportation system:

- Production
  - vehicle
  - energy/battery storage
- Operation
  - fuel/energy supply
  - fuel use
  - maintenance
- End of life
  - recycling and/or reuse
  - substitution of secondary material

The main influencing parameters on the global impacts should be identified and described.

### 1.6.3 Current minimum requirements

The current minimum requirements on LCA for EVs and ICEs should cover Global Warming and Primary Energy Consumption as major relevant global impact categories addressing the key issues of GHG-emissions and energy efficiency.

The following should be considered on these two global impact categories:

- Global Warming:
  - The Global Warming Potential is given in kg CO<sub>2</sub>-eq<sub>100</sub>.
  - The individual GHG-gases and their CO<sub>2</sub>-equivalent factor should be described, e.g. according to IPCC AR; now also biogenic based CH<sub>4</sub>-emissions have a different equivalent factor than fossil based CH<sub>4</sub> (e.g. from coal mining).
  - The contributions (%) of the most relevant individual GHG gases should be documented.
- Primary energy demand:
  - The Primary Energy Demand (PED) is also called Cumulative Energy Demand (CED) or Total Primary Energy (TPE) with analogue meaning
  - Primary energy demand is given in MJ
  - It must be specified if the methodology for the Primary Energy Demand is based on the lower (LHV) or higher heating value (HHV). The difference might be up to 5%, but there is no general agreement on the type of heating value.
  - Beside the total Primary Energy Demand also the share (%) of renewable and fossil and nuclear energy should be described.
  - Optionally it is also useful especially for EVs to identify the major primary energy carriers used, e.g. coal, natural gas, wind, hydro, solar, nuclear.



#### 1.6.4 Future advanced requirements

The future advanced requirements for impact assessment address

- Resource use, minerals and metals
- Water footprint (inventory level)
- Land use
- Ozone depletion

For EVs (incl. batteries) and renewable electricity generation the type and amount of material used in the construction phase becomes more relevant than for conventional vehicles using raw oil. Therefore the impact category of “Resource use, mineral and metals” also becomes a more relevant global impact category. Concluding, an advanced requirement for LCA should be to calculate the amount of material in the inventory analysis especially for the most relevant materials like Cu, Li, Co, Ni, Mn and others. Based on this inventory the resource use should be assessed on the basis of kg Sb-eq. and giving the main contribution from single minerals or metals.

Water issues are also relevant, especially for mining activities, Lithium extraction and hydro power. So on global scale the Water Footprint using the inventory based methodology should be assessed in future LCA of EVs and ICEs.

Also land use aspects are relevant for mining of raw materials as well as for renewable electricity production. As a next step in LCA of EVs the amount of land or land occupation over time should be analysed in the inventory phase by at least differentiation on the type of land: agriculture, forestry, infrastructure, industrial area or any other type of land.

The impact category “Ozone Depletion” can easily be addressed in LCA of EVs and ICEs, but seems currently of lower relevance for transportation systems, except from losses of fluids from cooling systems or their end of life treatment.

### 1.7 Conclusion and outlook

These global indicators also cover and address aspects of the two most relevant environmental aspects currently under public and political agenda e.g. GreenDeal:

- “Climate neutrality” and
- “Circularity”.

But as these aspects are relevant in a dynamic system perspective e.g. recycling to secondary material further methodological developments are necessary to integrate them in LCA.

Considering current international LCAs on EVs in comparison to ICE it becomes obvious that Global Warming and Primary Energy Consumption are a minimum requirement and state of the art in Impact assessment. LCAs disregarding one of these two impacts are too limited or misleading in their conclusions and interpretations.

It is expected that the other global impacts - Resource Use, Water Footprint and Land Use – will be analysed and assessed in LCA of EVs in future more often, using the rapid international progress made for inventory data.

Considering the local and regional impact categories in LCA further methodological developments, better inventory data and general acceptance are necessary. Or these

environmental impacts (e.g. biodiversity) will be addressed with other methodologies than LCA more adequate in future.

The new IEA HEV TCP Task 46 (2022 – 2024) “LCA of electric Trucks, Buses, 2-Wheelers and other Vehicles” will address these global impact categories further and intends to develop and discuss new approaches to address “Climate Neutrality” and “Circularity” of transportation system in (dynamic) LCA.

## 2 Introduction

Electric vehicles have the potential to substitute for conventional vehicles to contribute to the sustainable development of the transportation sector worldwide, for example, in the reduction of greenhouse gas (GHG) and particulate emissions. There is international consensus that the improvement of the sustainability of electric vehicles can only be analysed on the basis of life cycle assessment (LCA) (Figure 1), which includes the production, operation, and the end-of-life treatment of the vehicles and the fuel cycle. All environmental impacts must include the whole value chain, and - if relevant - interactions from recycling in the dismantling phase to the production phase, if recycled materials are used to produce new vehicles or other products.

The Implementing Agreement on “Hybrid and Electric Vehicle (HEV)” of the International Energy Agency (IEA) is operating the Task 30 “Assessment of Environmental Effects of Electric Vehicles” to examine the environmental effects of vehicles with an electric drivetrain based on life cycle analyses. The Task 30 started in 2016 and the end 2021. The main activities influencing the environmental impacts of electric vehicles on a life cycle basis are:

- 1) Production and life time of the battery,
- 2) Electricity consumption of the vehicle in the operation phase, incl. e.g. energy demand for heating,
- 3) Source of the electricity, only additional renewable electricity maximizes the environmental benefits and
- 4) End of life treatment of the vehicle and its battery (e.g. reuse, material recycling).

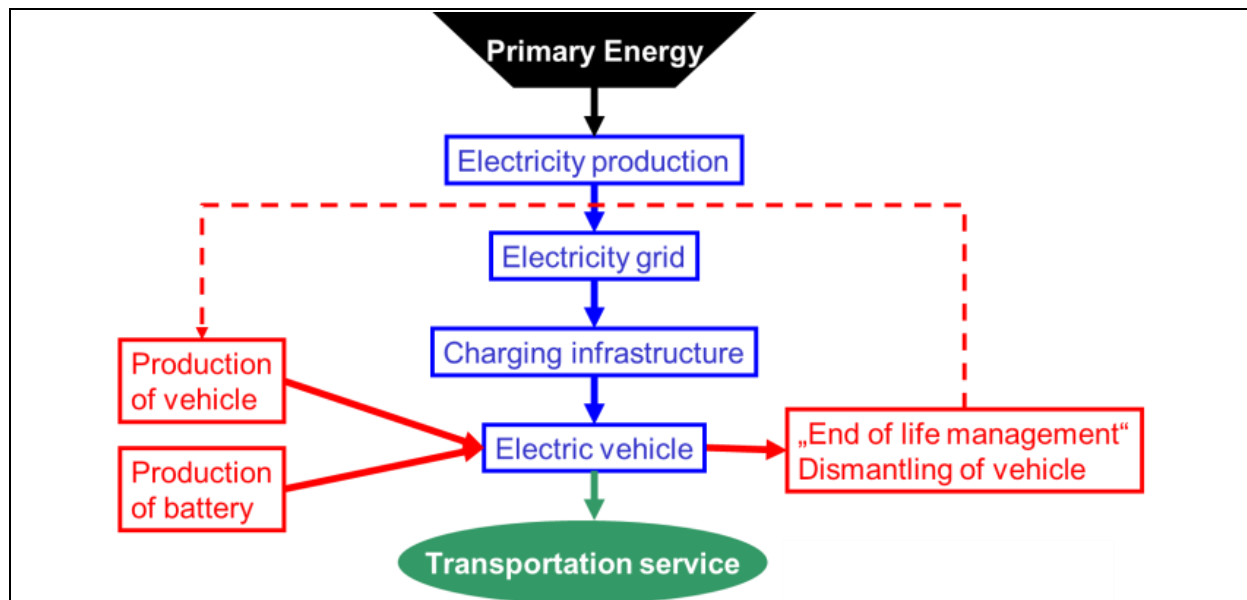

Figure 1: Key elements of the life cycle assessment of vehicles with an electric drive train

### **3 Aim of the workshop**

The aim of the expert workshop of Task 30 is to analyse and assess different Impact Assessment methodologies of battery electric vehicles (BEV) and conventional vehicles with an internal combustion engine (ICE). Based on the inventory analysis of Life Cycle Assessment (LCA) different impact categories beyond global warming and primary energy consumption are relevant. The way from Inventory Analysis to Impact Assessment is via mid- and end-point indicators, which will be analysed and discussed in the workshop.

The aim of the workshop is to present and discuss the status and the future perspectives of the Impact Assessment and its impact categories relevant for LCA of vehicles.

Based on presentations from invited experts and members from the task the key issues on Impact Assessment are identified and discussed in a group work among the different stakeholders. The result is a summary statement on the status of Impact Assessment methodologies and its future perspectives for electric and conventional vehicles.

The main topics for the workshop are:

1. LCA methodologies on Impact Assessment
2. Selection of impact categories
3. Necessary inventory data
4. Case studies of EVs, ICEs, batteries, electricity and conventional fuel production
5. Identification of key issues on overall impact assessment
6. Findings and Recommendations

The format of the workshop is based on presentations, discussion and group work.

The workshop is online and virtually hosted by IREC, Spain, October 13&14, 2021

## 4 Programm

*October 13, 2021*

*Brussels Time ZONE*

*The workshop is moderated by IREC*

11:00 Welcome and **Introduction** - Aims of the Workshop

11:10 – 11:30: **IEA HEV Task 30 “Assessment of Environmental Effects of Electric Vehicles”** Gerfried Jungmeier, JOANNEUM RESEARCH, AT

### Key Notes

11:30 – 12:15: **LCA of EV and ICE - Human Toxicity Potential, Abiotic Resource Depletion and Water- Scarcity**, Nikolas Hill, Ricardo Energy and Environment, UK, and Marco Raugei, Ricardo Energy and Environment, UK and Oxford Brookes University, UK

12:15 – 13:00: **Assessment Concept of Protection Areas - Human Health, Natural Resources and Natural Environment**, Fulvio Ardenete, JRC, Ispra, IT

13:00 – 13:45: **LCA of Passenger Vehicles - Impacts Beyond Climate Change**, Christian Bauer, PSI, CH

13:45 – 14:00: discussion

*14:00 – 14:30: Break*

14:30 – 15:15: **LCA of Electricity in Europe to 2050 - Beyond GHG and Primary Energy**, Nabil Abdalla, IFEU, DE

15:15 – 16:00: **Overview of the Commonly Used LCIA and LCI indicators in the Automotive LCA Studies in North America- Status-quo, Limitations and Future Perspective**, Lindita Bushi, Athena Sustainable Materials Institute, CA

16:00 – 17:00: **Statements on key issues on Impact Assessment** (interactions with and among participants)

*17:00 End of day 1*

**Highlights of LCA of EVs from Task 30 partners**

*October 14, 2021, Brussels Time ZONE*

**11:00 Welcome and Introduction**

11:15 – 11:45: **Benefits of Vehicle Electrification - GHG Emission of Vehicle Charging**, Tugce Yuksel, Sabanci University, Turkey

11:45 – 12:15: **Life Cycle Analysis of a Modular Vehicle Concept: Insights in the Methodological Approach and Initial Results**, Christian Ulrich, DLR, Germany

12:15 – 12:45: **Dynamic LCA for BEV Introduction and Development of Vehicle Fleet in Austria 2010 to 2050**, Gerfried Jungmeier, JOANNEUM RESEARCH, Austria

12:45 – 13:00: discussion

*13:00 – 13:30: Break*

**LCA and Impact Assessment in the USA**

13:30 – 14:00: **Cradle to Grave Lifecycle GHG and Cost Analysis of Current and Future Light Duty Vehicles in the United States**, Jarod C. Kelly, Argonne National Laboratory, USA

14:00 – 14:30: **TRACI\*): Current Status and Future Directions**, Jane Bare, EPA, USA

*\*) Tool for the Reduction and Assessment of Chemical and other environmental Impacts*

14:30 – 14:45: discussion and group formation (IREC)

*14:45 – 15:00: Break*

**Group work of LCA experts**

15:00 – 16:00 **Identification of key issues on Impact Assessment** (interactive group work)

- **Selection of Impact Categories and Assessment Methodologies** (V́ctor Joś Ferreira, IREC, ES)
- **Most Relevant Impacts for Comparing EVs and ICE** (Jarod Cory Kelly, Argonne, USA)

16:00 – 16:30: **Presentations of Group Work** (V́ctor Joś Ferreira and Jarod Cory Kelly)

17:00: **Summary and conclusions** (Gerfried Jungmeier, JOANNEUM RESEARCH, Austria)

*17:15 End of workshop*

## 5 Results

In this chapter, the main results from the workshop are summarized. The focus is put on the overall assessment in LCA of Electric Vehicles with its impact categories and assessment methodologies.

### 5.1 LCA of EV and ICE - Human Toxicity Potential, Abiotic Resource Depletion and Water- Scarcity

*Nikolas Hill, Ricardo Energy and Environment, UK, and Marco Raugei, Ricardo Energy and Environment, UK and Oxford Brookes University, UK*

- A wide range of Non-GHG indicators were assessed in Ricardo’s EC project, with HDP, ADP (minerals & metals) and Water Scarcity particularly relevant to xEVs:

Impact Category	Indicatory and unit	Original source
Human Toxicity Potential (HTP)	<ul style="list-style-type: none"> <li>• HTP is a measure of the impacts on human health. Characterisation factors describe the fate, exposure and effects of toxic substances over an infinite time horizon. Units for HTP are in “Comparative Toxic Unit for Human Health”, <b>CTUh</b></li> </ul>	USEtox (Rosenbaum et al 2008)
Abiotic Depletion Potential – Minerals & Metals (ADP_MM)	<ul style="list-style-type: none"> <li>• ADP_MM concerns the extraction of scarce minerals. Values are determined for each extraction of minerals based on the remaining reserves and rate of extraction. Units for ADP ultimate reserves are in <b>t Sb eq</b></li> </ul>	Van Oers et al. 2002
Water Scarcity (WaterS)	<ul style="list-style-type: none"> <li>• Water scarcity is an indicator from the AWARE characterisation model that provides an assessment for water consumption. Units for scarcity-adjusted water use are in <b>m<sup>3</sup> world eq</b></li> </ul>	AWARE 2016

### Comparing BEV and ICE

- Impacts from HTP, ADP (minerals & metals) and Water Scarcity show often quite different trends to those seen for Global Warming and GHG Emissions
- Human Toxicity Potential, HTP:
  - Majority of impacts are due to materials used in vehicle and battery manufacturing
  - For conventional powertrains, smaller impacts due to fuel production and maintenance (replacement of aftertreatment system)
  - For xEVs, higher impacts due mainly to battery materials:
  - Mostly due to copper from the battery anode current collector, Copper in wiring and motor contribute to a much smaller extent (<20%)
  - Reductions to 2050 due to improved battery energy density (Wh/kg)



- HTP metric does not cover the notable impacts from exhaust air quality pollutants (i.e. CO, NO<sub>x</sub>, PM, SO<sub>2</sub>, VOC, etc.), though these have established human health respiratory impacts
- HTP factor is perceived to have a lower level of robustness – so significance should not be overstated in overall comparisons
- Useful to identify areas for future improvements
- Abiotic Depletion Potential, minerals and metals, ADP\_MM:
  - Similarly to HTP, impacts predominantly due to manufacturing and EoL stages due to materials: For conventional vehicles, impacts from production phase are predominantly due to steel for the glider
  - Positive impacts (rather than credits) in EoL stage due to impacts of aluminium recycling (it is unclear why this should be)
  - For xEVs, extra impacts from electronics and copper in batteries: Underlying Li, Ni, Co materials (used in small % in batteries) do not appear to significantly contribute to the total (but are still clearly important / scarce resources)
  - Electricity: Impacts relatively small component of total: Relatively very high impacts for solar PV generation - much higher than other generation types. Also much higher for wind, nuclear vs other generation
  - For FCEV operating on Green (renewable) hydrogen production, the effect of impacts from solar PV are magnified through losses: Impacts from vehicle production are lower vs BEV
- Water Scarcity, WaterS
  - Impact predominantly from energy production (WTT) stage – accounts for over 90% of total impacts
  - For electricity: highest impacts for coal and solar generation types – similar magnitude (other generation types lower)
  - Metric doesn't necessarily capture/highlight localised issues well – for example water consumption for lithium extraction (as Li is a small % of the total battery bill-of-materials)
  - For FCEVs, impacts are highest for electrolysis routes and there is a higher share of electrolysis in 2050 vs 2020 for the Tech1.5 mix of hydrogen production: Impacts could be mitigated by locating producing hydrogen nearer less scarce sources, or using desalinated water (but this will increase other impacts, e.g. GHG, cumulative energy)

### Impact assessments methodologies:

- Abiotic depletion
  - The Abiotic Depletion (AD) impact category pertains to the wider LCA Area of Protection (AoP) “natural resources
  - Different LCIA methods address AD in slightly different ways, but all fundamentally hinge on quantitative estimates of reserve bases and extraction rates

- Energy inputs (e.g., fossil fuels and uranium) are typically excluded, to focus on the depletion of non-energy mineral resources, and specifically metals
- Different modelling approaches reflect different perspectives on the “role” of natural resources
- 

- A. abiotic resources are valued by **humans** for their functions used (by humans) **in the economy**, **primary production only**
- B. abiotic resources are valued by **humans** for their functions used (by humans) **in the economy**, **primary and secondary production**
- C. abiotic resources are valued by **humans** for their in-situ functions **in the environment**, **primary production only**
- D. abiotic resources are valued by **humans** for their functions in the **economy** and their in-situ functions **in the environment** considered useful to humans, **primary production only**
- E. abiotic **resources** are valued for their own sake **in the environment**, regardless of their usefulness in environment or economy, **primary production only**

- AD methods mainly differ in terms of time horizon (e.g., focus on long-term depletion potential vs. short-term supply risk), and associated assumptions on reserve bases:
  - The CML ADPultimate reserves uses current extraction rates and assumes stock estimates = total crustal contents:
    - Total crustal content is chosen as the best available proxy for “ultimately extractable” reserve, since the latter is a moving target that depends on unknown future technological developments.
    - Mid-point CFs are expressed in terms of kg(Sb-equivalent).
    - Method originally developed in 1995, then CFs updated in 2002 and 2019.
    - This method is “recommended” by UNEP/SETAC Life Cycle Initiative, and by EC-JRC
  - ADPeconomic reserves alternatively assumes stock estimates = those that are economically extractable at present
    - Mid-point CFs are still expressed in terms of kg (Sb-equivalent).
    - This method better highlights the more imminent pressure on resource availability
    - BUT, it suffers from two main weaknesses:
      - Anthropogenic stocks (e.g., secondary sources) are excluded
      - Economic reserve estimates tend to increase over time, leading to potential underestimation of depletion threat

- This method is only “suggested” but not officially “recommended” (a much weaker endorsement)
- Human Toxicity
  - The Human Toxicity (HT) impact category pertains to the wider LCA Area of Protection (AoP) “human health”
  - Different LCIA methods have been developed to address HT (and Ecosystem Toxicity)
  - In 2005, a comprehensive comparison of the existing methods was initiated by the UNEP-SETAC Life Cycle Initiative
  - This led to a new consensus model: USEtox (<http://usetox.org>)
  - USEtox is now recommended as the “best” available method by UNEP-SETAC, and also recommended by EC-JRC for Product Environmental Footprints
  - Framework for characterizing toxicity impacts with USEtox: Very complex model reliant on many factors and difficult estimates and assumptions (even at mid-point level)
  - In USEtox, a distinction is made between “interim” and “recommended” characterisation factors
  - This reflects the different level of reliability of the calculations
  - CFs for metals are classified as “interim” due to high uncertainty on fate and exposure
  - Mid-point CFs for HTP are expressed in units of adimensional “comparative toxic units, human” (CTUh), = estimated increase in morbidity in the total human population per unit mass of a chemical emitted (i.e., cases per kilogram)
  - Separate “cancer” and “non-cancer” CTUh are provided, but both have default equal weighting, in lack of more precise insights
  - End-point CFs (DALY) are also optionally provided, but these entail further assumptions and uncertainty, and are not ISO-compliant for all “comparative assertions intended for public disclosure” (ISO 14044)
- Abiotic Depletion and Human Toxicity – Take-home points:
  - These are still arguably the LCIA impact categories that are most affected by uncertainty and lack of precision
  - ADP’s dependence on current extraction rates and estimated ultimate reserves makes it susceptible to obsolescence, especially when it is used to assess scenarios unfolding over several decades into the future
  - HTP suffers from the fundamental intrinsic methodological challenge of comparing and combining the individual toxicity potentials of a wide and diverse range of organic and inorganic emissions
  - HTP also critically depends on hard-to-quantify (and intrinsically variable) fate and exposure factors
  - HOWEVER, in spite of all these limitations, these two impact categories (and the related indicators) still offer the best available insights into two CRUCIAL ASPECTS of environmental impact, which are especially key for new

technologies heavily reliant on metal resources, such as batteries, electric motors and renewable energies

- ULTIMATELY, it should be kept in mind that LCA’s main asset is its ability to provide a comprehensive picture of environmental impact, and highlight potential risks of impact shifting
- The emphasis should be on results that are ACCURATE (to the extent possible), NOT PRECISE (per se)!

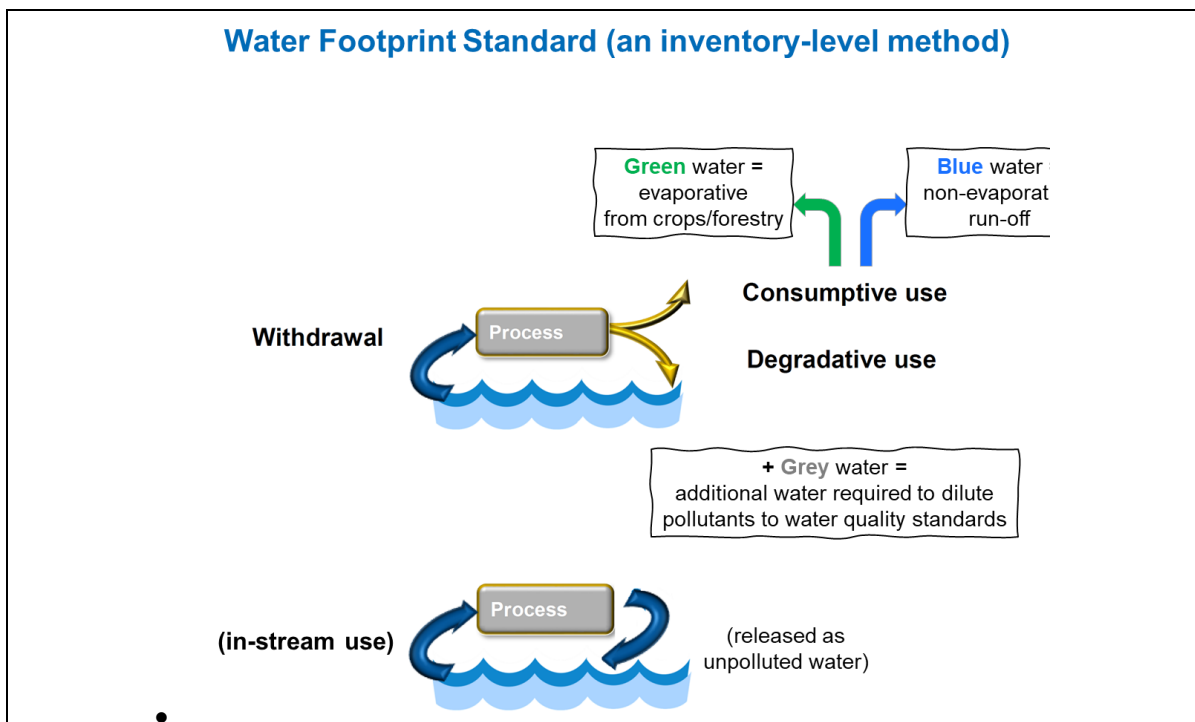

- Water Footprint (an inventory level method) Source: <https://waterfootprint.org/en/resources/publications/water-footprint-assessment-manual-global-standard>

- Water Scarcity LCIA methods:
  - Water Stress Index (WSI): Regionalised mid-point characterization model based on withdrawal-to-availability ratio
  - WSI indicates the portion of WUconsumptive that deprives other users of freshwater
  - Further converted to end-point indicators for Ecosystem Quality (EQ) and Human Health (HH), the latter based on competition with irrigation
  - Available WAtER Remaining (AWaRe): Regionalised mid-point characterization model based on withdrawal-to-availability ratio
  - New consensus method of UNEP/SETAC working group on water use in LCA (WULCA)

- Suggested by EC-JRC as new standard impact assessment method for water use in PEF
- Conclusions:
  - Part I: At a High-Level: What has / can vehicle LCA tell us about the impacts of different vehicles / powertrains / fuels, and circular economy? What are the key challenges for LCA and areas where other complementary approaches are needed?
    - Key findings and benefits of vehicle LCA:
      - Helped to confirm significant GHG benefits for xEVs over other types of powertrain that also increase over time
      - Also helped identify the significance of key uncertainties and assumption via sensitivities
      - Highlighted hotspots, e.g. for xEVs due to certain materials through Human Toxicity Potential and Abiotic Resource Depletion; also Water Scarcity for FCEVs (H2 via electrolysis)
      - Cumulative energy demand is much higher for FCEVs than BEVs due to the less efficient end-to-end energy chain (more so for e-fuels)
      - EoL methodologies help illustrate the benefits (also for the circular economy) for vehicle recycling and battery 2nd life applications
  - Challenges for LCA and future improvements:
    - Highly complex; further standardisation / vehicle LCA PCR (product category rules) needed to facilitate comparisons → EU policy?
    - Different methodologies and assumptions can have significant impacts on the result
    - Need improved LCI and real-world datasets
    - Resource issues not always captured well by current LCA impact categories (e.g. Li /Co /Ni)
    - Complementary fleet/system modelling needed to capture resource flows / implications
    - Uncertainty on EoL methods/data, future battery recycling / recovery levels and impacts
    - Improved policy needed on 2<sup>nd</sup> life batteries, and methodologies for assessing repurposing and 2<sup>nd</sup> life impact/credits are needed
  - Part II: Main take-home points for the transition from ICEVs to Evs, with special focus on ADP, HTP and WaterS
    - Key methodological findings:
      - LCA is a powerful (if still imperfect) tool
      - HTP, ADP and WaterS are important impact categories, too often neglected in many LCAs

- They highlight criticalities, trade-offs and potential impact-shifting in the transition to electric mobility
- They are affected by a comparative lack of precision, but this should not discourage their use – in LCA, accuracy trumps precision
- Whole-fleet studies are needed to capture system-level impacts, especially in terms of key resource availability
- Challenges and strategies to address them
  - Moving from ICEVs to xEVs is beneficial in terms of GWP and CED, but it entails trade-offs in terms of HTP, ADP and WaterS
  - There are no all-round “silver bullets”
  - EoL recycling is an effective – and much needed – strategy to “close the loop” on critical metals – but it is not enough
  - Large-scale environmental problems cannot be “solved” by technological fixes alone
  - Societal & behavioural changes are needed
  - Significant resource demand and associated impact reductions can be achieved by shifting to shared mobility

## 5.2 Assessment Concept of Protection Areas - Human Health, Natural Resources and Natural Environment



*Fulvio Ardente, JRC, Ispra, IT*

- LCA is a powerful method, but implementation in robust certification schemes and/or policies is challenging:
  - variety of modelling approaches
  - different impact assessment methods
  - Interpretation flexibility



Impact category	Impact category Indicator (unit of measure)	Description
 Climate change, total	Radiative forcing as global warming potential – GWP100 (kg CO <sub>2</sub> eq)	Increase in the average global temperature resulting from greenhouse gas emissions (GHG)
 Ozone depletion	Ozone Depletion Potential – ODP (kg CFC-11 eq)	Depletion of the stratospheric ozone layer protecting from hazardous ultraviolet radiation
 Human toxicity, cancer	Comparative Toxic Unit for humans (CTUh)	Potential impacts on human health via ingestion and inhalation routes. Contact and direct exposures not modelled.
 Human toxicity, non-cancer	Comparative Toxic Unit for humans (CTUh)	
 Particulate matter	Impact on human health (disease incidence)	Impact on human health caused by particulate matter emissions and its precursors (e.g. sulfur and nitrogen oxides)
 Ionising radiation, human health	Human exposure efficiency relative to U-235 (kBq U-235 eq)	Impact of exposure to ionising radiations on human health
 Photochemical ozone formation, human health	Tropospheric ozone concentration increase (kg NMVOC eq)	Potential of harmful tropospheric ozone formation (“summer smog”) from air emissions
 Water-use	Weighted-user-deprivation-potential-(m <sup>3</sup> world-eq)	Depletion-of-available-water-depending-on-local-water-scarcity-and-water-needs-for-human-activities-and-ecosystem-integrity

Selected (mid point) impact categories in Environmental Footprint (I)

 Acidification	Accumulated Exceedance – AE (mol H <sup>+</sup> eq)	Acidification from air, water, and soil emissions (primarily sulfur compounds) mainly due to combustion processes in electricity generation, heating, and transport
 Eutrophication, terrestrial	Accumulated Exceedance – AE (mol N eq)	
 Eutrophication, freshwater	Fraction of nutrients reaching freshwater end compartment (kg P eq)	Eutrophication and potential impact on ecosystems caused by nitrogen and phosphorous emissions mainly due to fertilizers, combustion, sewage systems
 Eutrophication, marine	Fraction of nutrients reaching marine end compartment (kg N eq)	
 Ecotoxicity, freshwater	Comparative Toxic Unit for ecosystems (CTUe)	Impact of toxic substances on freshwater ecosystems
 Land use	Soil quality index, representing the aggregated impact of land use on: Biotic production; Erosion resistance; Mechanical filtration; Groundwater replenishment (Dimensionless – pt)	Transformation and use of land for agriculture, roads, housing, mining or other purposes. The impact can include loss of species, organic matter, soil, filtration capacity, permeability
 Resource-use, minerals and metals	Abiotic-resource-depletion-ultimate-reserves-(kg-Sb-eq)	Depletion-of-non-renewable-resources-and-deprivation-for-future-generations
 Resource-use, fossils	Abiotic-resource-depletion, fossil-fuels-(ADP-fossil)-(MJ)	

Selected (mid point) impact categories in Environmental Footprint (II)



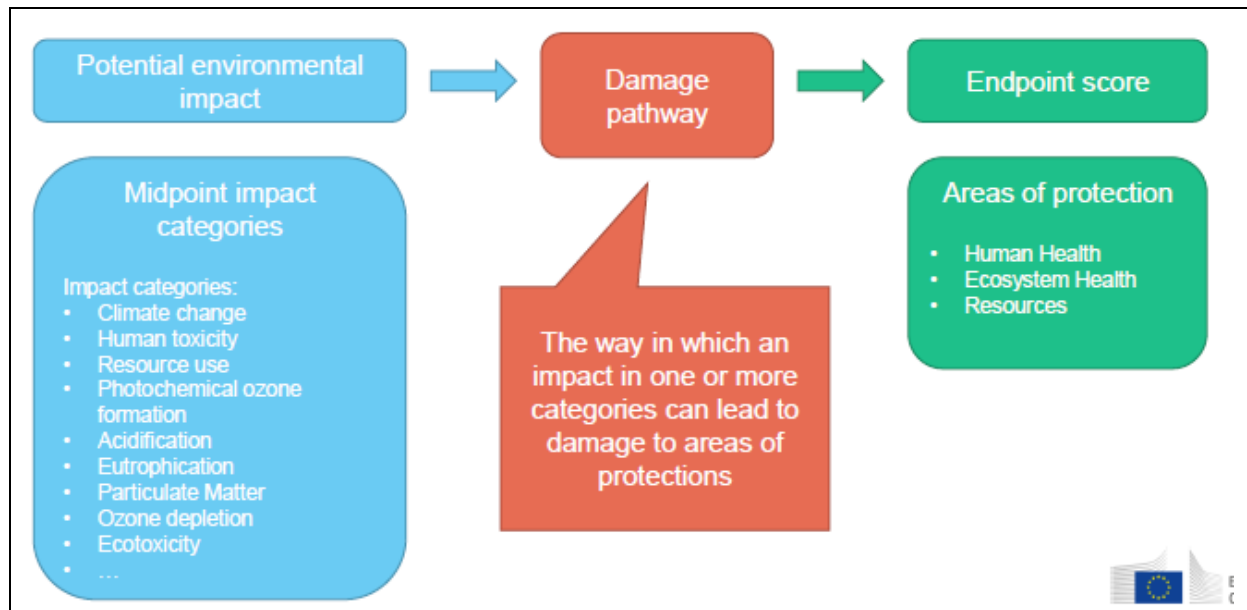

### From impact categories to areas of protection

- Human health:
  - In the Area of Protection “Human Health”, damages to human health from various sources are assessed.
  - The common endpoint unit used here is the DALY (Disability Adjusted Life Years). This metric accounts for the number of years a someone loses due to environmental impacts
- Ecosystem quality:
  - “Ecosystem quality” is the Area of Protection that accounts for impacts on ecosystems, focusing on biodiversity loss.
  - The most used endpoint unit is the PDF (Potentially Disappeared Fraction of species). This metric accounts for a fraction of species richness that may be potentially lost due to human pressure on the environment
- Resources:
  - The Area of Protection Resources ” considers damages on the natural resources.
  - The endpoint can be expressed in kilogram ore, i.e. the extra mass of ore extracted in the future. This Area of Protection considers changes and scarcity in the availability and quality of resources
- Challenges and Ongoing discussion:
  - Currently the EF method has been oriented the implementation of midpoint assessment instead of endpoint
    - Midpoint impact categories are considered more reliable
    - Assessment of damage usually introduce uncertainty and scientific consensus is less solid

- Challenges include uniformity of data (nomenclature and
- Completeness vs Stability of the recommended methods
- Discussions are ongoing to evaluate the possibility to include also endpoint damages in future
- Normalisation and weighting
  - Definitions:
    - Normalisation: *Calculating the magnitude of category indicator results relative to reference information.* Reference could be the total impact on each category at global level. The result is the impact expressed in “person equivalent ” (global
    - Weighting: *Converting and possibly aggregating indicator results across impact categories using numerical factors based on value choices.* This step is useful to rank impact categories based on expert judgments on criticalities and/or policy relevance
  - A step forward to facilitate interpretation is achieved in EF implementing normalisation and weighting at midpoint level
  - These steps are compulsory in the EF method
- Resources: Five perspectives result to define Safeguard Subjects for the AoP Natural Resources
  - The asset:
    - Abiotic resource (stocks)
    - Abiotic resources (flows)
    - Air and water
    - Natural biomass
    - Land and water surface
  - The provisioning capacity (= Provisioning functions for humans)
    - Energy provision
    - Material provision
    - Food provision
    - Space provision
  - The global function:
    - Provisioning functions for humans
    - Non-Provisioning functions for humans
    - Functions beyond human needs
  - The supply chain:
    - Provisioning functions for humans
    - Resulting products and services for human welfare
  - Human welfare:

- Provisioning functions for humans
- Non-Provisioning functions for humans
- Functions beyond human needs
- Resulting products and services for human welfare
- From Resources depletion to resource dissipation:
  - Based on experience matured in the EF pilot, it has been recognised that the consumption of resources does not represent an impact itself (a lot depends on how resources are used in the economy)
  - This is also in line with the EU Circular Economy Action Plan, fostering the need to keep resources as longer in use in our economy
  - The focus needs to be shifted from resource use to Resource dissipation
  - JRC started to develop a method to account for resource dissipated across the life cycle (including those dissipated in environment, tailings, landfills, and as non-functional recycling)
- Toxicity:
  - Aiming at scientific consensus, the EF impact assessment employ the USEtox multimedia fate modelling method
    - The input data have been revised to align them with official data used in EU, e.g. from ECHA ( REACH) and EFSA
    - The approach results in improved coverage of chemical substances characterised
    - that in EF much more substances are evaluated in terms of potential toxicity
    - JRC has also joined the debate at the UN Life cycle initiative.
    - Based on intensive testing (during the EF pilot and transition phase), additional revisions has been carried out:
      - For Ecotoxicity, a more conservative approach has been applied: HC20 has been used, instead of the HC50 , (accordingly to scientific community recommendations)
      - CF of some substances have been corrected to avoid anomalous results for some substances (to reflect their effective impacts on human and ecosystems)
- Biodiversity:
  - Ongoing efforts of the JRC within dedicated working groups.
  - JRC is exploring LCIA methods and approaches addressing impact on biodiversity to be potentially integrated in the EF method in the future
  - Currently, operational and novel methods addressing impact on biodiversity at the midpoint and endpoint (that take into account different midpoint impacts such as Climate Change, Land Use, etc.) are under test by the JRC

- Key aspect is to judge how these methods can be operable and in line with current inventory phase
- PEFCRs for rechargeable batteries available (as the most critical component for the LCA of EVs)
  - PEF Category Rules (PEFCR): Prescriptions in PEFCRs for the LCIA
  - Materiality approach
  - Procedure to identify the most relevant impact categories
  - Procedure to identify the most relevant life cycle stages / relevant process and elementary flows
  - Functional Unit: 1 kWh of the total energy provided over the service life by the battery
  - Representative product Li ion for e mobility:
    - Battery cells
    - Safety management unit with
      - BMU (Battery management unit)
      - BCU (Battery control unit)
      - ThMU (Thermal management unit)
      - Charger (excluded)
- PEFCR are developed based on the Representative Product:
  - Virtual product are calculated based on average European market sales weighted characteristics of all existing technologies/ materials in the product category.
  - The PEF profile (LCIA results) of the representative product corresponds to the benchmark of the product category/sub category

Most relevant impact categories

	e-mobility Li-ion
Acidification terrestrial and freshwater	2%
Climate Change (biogenic)	0%
Climate Change (fossil)	32%
Climate Change (land use change)	0%
Eutrophication freshwater	0%
Eutrophication marine	1%
Eutrophication terrestrial	2%
Ionising radiation - human health	3%
Land Use	0%
Ozone depletion	0%
Photochemical ozone formation - human health	3%
Resource use, energy carriers	26%
Resource use, mineral and metals	20%
Respiratory inorganics	8%
Water scarcity	2%

### Impact assessment of the Representative Product

- PEFCR in policy: New Battery Regulation
  - Lays down rules on the carbon footprint of electric vehicle batteries and rechargeable industrial batteries
  - Batteries shall be subject to classification into carbon footprint performance classes
  - Batteries (2 kWh capacity) will need to comply with maximum life cycle carbon footprint thresholds to be placed on the EU market
  - Calculation rules shall build in compliance with the latest version of the PEF method and PEFCRs for batteries
- Conclusions
  - Within the EPLCA the JRC has carried out a long standing research on the evaluation of robust methods for Life cycle impact assessment
  - These have been progressively reviewed / updated / modified to reflect also testing on different sectors
  - Criteria for the selection of impact assessment methods include, among the other, practical operability (with current LCA data) and robustness (building a consensus within scientific community).
  - LCIA methods have been progressively implemented in tools for the market and policies as the EF
  - Research is focusing on the way forward, exploring also end point methods and different perspectives (developments on going on resource dissipation, human toxicity, biodiversity).
  - Electric vehicle batteries is first example of direct implementation of LCA into mandatory EU policy (although, so far, limited to climate change impact only)

### 5.3 LCA of Passenger Vehicles - Impacts Beyond Climate Change

Christian Bauer, PSI, CH

- Environmental life cycle impacts beyond climate change
  - Traditional Life Cycle Impact Assessment (LCIA) indicators, covering impacts on:
    - Human health
    - Ecosystems
    - Resources
  - Quantification of external costs via Impact Pathway Approach (IPA), covering:
    - Climate change impacts
    - Regional air pollution
    - Land use

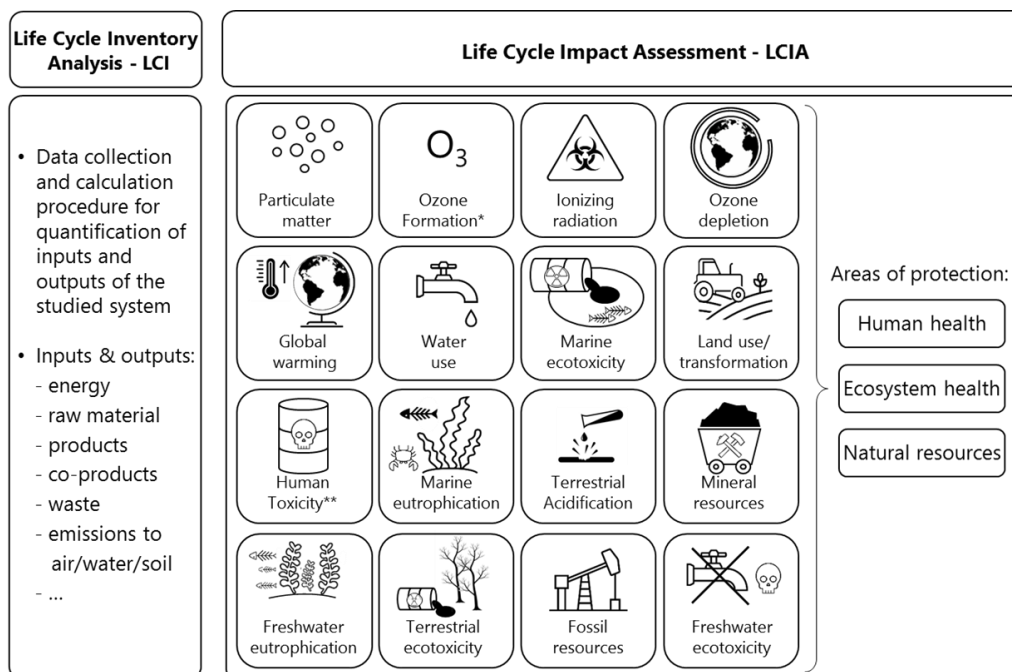

Life Cycle Impact Assessment – LCIA: ILCD midpoint indicators and Step-wise 2006 overall aggregation via endpoints

- Traditional LCIA indicators: limitations and challenges
  - Meaningfulness: to which extent do «normal» LCIA results represent REAL environmental or health concerns?
    - Lack of geographical resolution and representativeness
    - Limited information on real supply chains
    - Partially outdated LCI

- Location-specific impacts are not considered
  - Uncertainties
    - Hardly quantified
    - Non-reliable LCI uncertainties
    - Uncertainties of impact assessment not taken into account
  - Limitations in LCI
    - Recycling
    - Dealing with multi-output processes in metal mining
    - Noise
- Impact Pathway approach (IPA) – quantification of external costs
  - Emissions: from vehicle and from rest of the chain
  - Dispersion and chemical reactions: e.g. change of pollutant concentration (mid-point impacts)
  - Impacts on receptors: human health, crop yields, buildings, land , ecosystems (end point impacts)
  - Valuation: external costs or indicators
  - Partially location-specific quantification of health impacts and environmental damage
  - Main external cost of vehicles (conv. ICE and BEV, not biofuels): climate change, regional pollutants
- Impact Pathway Approach – external costs: limitations & challenges:
  - Overall aggregation – monetization
    - Damage costs vs. Willingness-to-Pay
    - Discount factors
    - Uncertainties and approaches: Large range of costs
  - Limited applicability/scalability: Case-specific modeling required
  - Partial location-specificity: Mainly relevant for BEV with large impacts from manufacturing chains
  - Boundaries – which costs to include?: Congestion, accidents, time spent,...
  - Further challenges – as for LCIA: Recycling, missing supply chain data, uncertainties
- Outlook and recommendations: impacts beyond climate change:
  - Regionalized LCIA is required for most impact categories; otherwise LCIA results are hardly meaningful and penalise BEV and FCEV: Requires supply chain data and regionalized damage factors
  - Collaboration with other disciplines (e.g. atmospheric modelling) seems to be useful
  - Health impacts of noise should be taken into account in a meaningful way



- Recycling needs to be modelled in better ways: Important for BEV and FCEV
- Uncertainties (incl. Impact assessment) should be quantified and disclosed
- Communication of non-GHG related impact categories needs to be improved

### 5.4 LCA of Electricity in Europe to 2050 - Beyond GHG and Primary Energy

Nabil Abdalla, IFEU, DE

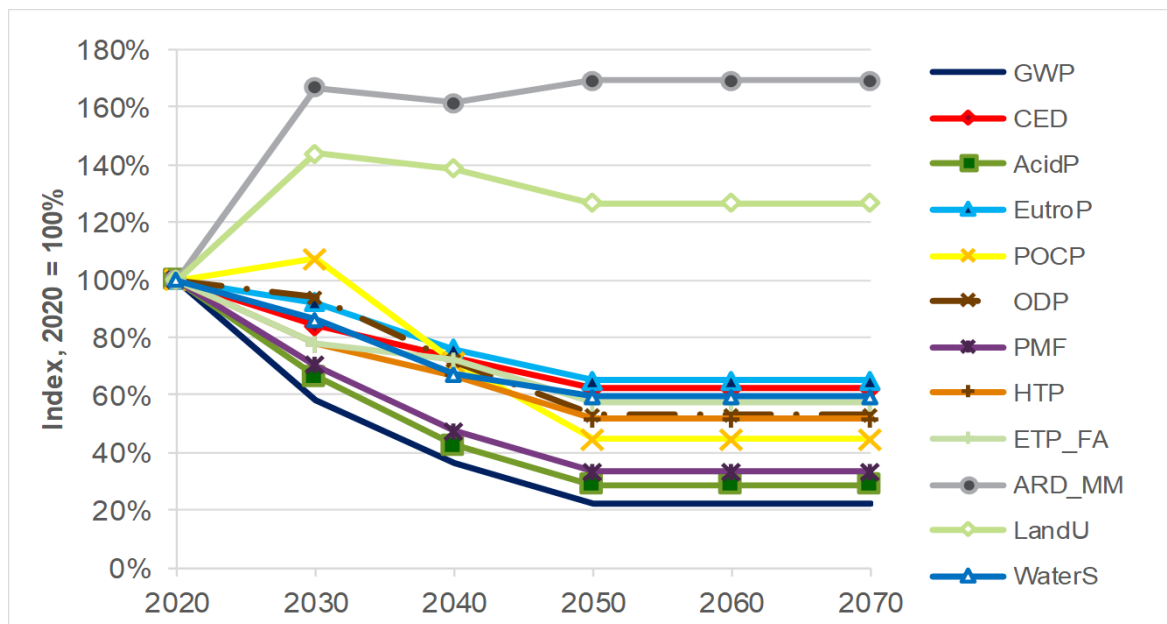

- The European electricity market will change significantly
- Different nations pursue different goals / strategies
- Results for two scenarios showed clearly observable trends
- Most impact categories show fewer harmful emissions and thus better results, reflecting the change in power market composition
- Two impact categories show worse results: Land Use (LandU) and abiotic resource depletion (minerals and metals) (ARD\_MM). This is a result of high specific factors for biomass (LandU) and solar (ARD\_MM)
- Impacts on EVs and transport in general?
- Manufacturing processes for all types of vehicles consumes electricity □ results should reflect developments in the electricity sector
- WtW-LCA of EVs vs other concepts is particularly impacted, following the significance of electricity for BEVs, H(B)EVs, PtX-fuels as well as hydrogen (FC)

## 5.5 Overview of the Commonly Used LCIA and LCI indicators in the Automotive LCA Studies in North America- Status-quo, Limitations and Future Perspective

*Lindita Bushi, Athena Sustainable Materials Institute, CA*

- Business-to-Business Communication (1) - Two Commonly used Environmental Indicators in the Automotive LCA studies:
  - Climate Change: GWP in kg CO<sub>2</sub>equivalent using IPCC AR 4, 2007 and IPCC AR 5, 2014
  - Primary Energy Demand: PED/TPE (NRPE, RPR) MJ, HHV or LHV; CED methodology (HHV, LHV)
- There are two Major Automotive Materials - Steel and Aluminium
  - North American Steel Data - Reported Impact Categories:
    - Primary energy demand (PED), including energy from non-renewable and renewable energy sources (LHV)
    - Global Warming Potential (GWP 100)-TRACI v2.1<sup>1</sup>, IPCC 2013 AR5,
    - Acidification Potential (AP), TRACI v2.1
    - Smog Formation Potential (SFP), TRACI v2.1
    - Eutrophication Potential (EP), TRACI v2.1
    - Ozone depletion potential (ODP), TRACI v2.1
    - Human health particulate potential (HHPP), TRACI v2.1
    - Water Consumption (inventory indicator)
  - North American Aluminum Data –Reported Impact Categories
    - Primary energy demand (PED), including energy from non-renewable and renewable energy sources,
    - Global Warming Potential (GWP100)-TRACI v2.1, IPCC 2013 AR5,
    - Acidification Potential (AP), TRACI v2.1
    - Smog Formation Potential (SFP), TRACI v2.1
    - Eutrophication Potential (EP), TRACI v2.1.
- US EPA Tool for the Reduction and Assessment of Chemical and Other Environmental Impacts (TRACI), v2.1, 2012
  - Climate change
  - Ozone depletion
  - Ecotoxicity
  - Human health cancer
  - Human health noncancer

<sup>1</sup> TRACI v2.1 2012 -Tool for the Reduction and Assessment of Chemical and Other Environmental Impacts, developed by the US Environmental Protection Agency (EPA).

- Particulate Matter Respiratory effects
- Photochemical Ozone (Smog) Formation
- Acidification
- Eutrophication
- Fossil fuel depletion

Impact Category	Methodology	Midpoint Units	Media
Climate change	IPCC 2007 AR4 (revised 2011) (Solomon et.al 2011)	kg CO <sub>2</sub> eq	Air
Ozone depletion	WMO 2003 and US EPA (2008a, 2008b, 2008c)	kg CFC-11 eq	Air
Ecotoxicity	USEtox model (Rosenbaum et. al. 2011) and USEPA (Bare 2012)	Comparative Toxic Unit for ecosystems (CTUe)	Urban air, nonurban air, freshwater, seawater, natural soil, agricultural soil
Human health cancer	USEtox model (Rosenbaum et. al. 2011) and USEPA (Bare 2012)	Comparative Toxic Unit for human (CTUh)	freshwater, seawater, natural soil, agricultural soil
Human health noncancer	USEtox model (Rosenbaum et. al. 2011) and USEPA (Bare 2012)		
Particulate Matter Respiratory effects	Humbert (2009) adjusted for North America	kg PM <sub>2.5</sub> -eq	Air
Photochemical Ozone (Smog) Formation	Maximum Incremental Reactivity (MIR) method, Carter (2012)	kg O <sub>3</sub> eq	Air
Acidification	US EPA (Bare et al. 2003)	kg SO <sub>2</sub> -eq	Air
Eutrophication	US EPA (Bare et al. 2003)	kg N-eq	Air, Water
Fossil fuel depletion	US EPA (Bare et al. 2003) and Eco-Indicator 99 (Goedkoop and Spriensma 2001)	MJ surplus	Natural resources

Source: Schenck R and White P, 2014, modified

- CSA LCA Guidance Document for Auto parts –LCIA Categories and LCI Indicators (1)
  - Acidification
  - Eutrophication
  - Climate change
  - Smog
  - Human health Particulate
  - Ozone depletion

LCI indicator	Unit
Non-renewable-fossil <sup>1)</sup> (natural gas, crude oil, hard coal, lignite, coal mining off-gas, peat)	MJ
Non-renewable-nuclear <sup>1)</sup>	
Non-renewable-biomass <sup>1)</sup> (wood and biomass from primary forests — clear cut)	
Renewable-hydropower <sup>1)</sup> (hydropower)	
Renewable- solar, geothermal, wind <sup>1)</sup> (solar, geothermal, wind)	
Renewable- biomass <sup>1)</sup> (wood, food products, biomass from agriculture)	
Use of non-renewable material resources	kg
Use of renewable material resources	kg
Water consumption	m <sup>3</sup>

**Note:** Sub-set of cumulative energy demand (CED) [12].

- TRACI 2.1 categories typically excluded from Automotive LCA studies in North America
  - Human health, cancer
  - Human health, non-cancer
  - Ecotoxicity
  - Fossil fuel depletion
  - Water scarcity
  - Land use
  
- Business-to-Consumer Communication (3) –Comparative footprint communications
  - ISO 14026:2017 Environmental labels and declarations —Principles, requirements and guidelines for communication of footprint information
  - <https://www.iso.org/standard/67401.html>
  - Comparative footprint communications
  - 6.9.2 Requirements for all comparative footprint communications
  - Comparative footprint communications of products shall only be used if the footprints used in the comparison take all relevant stages of the life cycle into consideration.
  - The same life cycle stages shall be used for all products in the comparison and a stage of the life cycle shall only be left out of the comparison if the impacts associated with that stage can be demonstrated to be insignificant for that product category.
  
- LCIA Indicators to be included in future automotive LCA studies:

- Water scarcity
- Resource use, mineral and metals
- Land use

LCIA indicators	Indicator, Units	Methodology	EVs	ICEs
Water scarcity <sup>*)</sup> <b>Global</b>	m <sup>3</sup> water eq. deprived, m <sup>3</sup>	Available <b>W</b> ater <b>R</b> emaining (AWARE) as recommended by UNEP, (Boulay A.M. et. al. 2016).	Yes	Yes
Resource use, mineral and metals <sup>*)</sup> <b>Global</b>	Abiotic resource depletion (ADP ultimate reserve), kg Sb-eq.	ADP for mineral and metal resources, based on van Oers et al. 2002 as implemented in CML, v. 4.8 (2016).	Yes	Yes
Land use <sup>*)</sup> <b>Global</b>	Soil quality index, dimensionless	JRC based on LANCA <sup>®</sup> v 2.2 as baseline model	Yes	Yes

<sup>\*)</sup> Used in EF method, the impact assessment method of Environmental Footprint (EF), initiative introduced by the European Commission.

### Limitations and future perspectives:

1. Climate Change results should specify the IPCC AR# – e.g., IPCC 2007 AR 4 or IPCC 2013 AR5 GWPs. The GWP 100a per IPCC 2013 AR5 (in kg CO<sub>2</sub>eq.): CO<sub>2</sub>=1; CH<sub>4</sub>, fossil=30; CH<sub>4</sub>, biogenic=28; N<sub>2</sub>O=265. The GWP 100a per IPCC 2007 AR4 (in kg CO<sub>2</sub> eq.): CO<sub>2</sub>=1; CH<sub>4</sub>, fossil =25; CH<sub>4</sub>, biogenic=22.25; N<sub>2</sub>O=298.
2. TPE results should specify the methodology – e.g. CED HHVs or CED LHVs -There are slight differences on HHVs and LHVs based on the data source and LCA software.
3. New edition of TRACI should include “Water Scarcity”, “Resource use, mineral and metals” and “Land Use” impact categories based on the scientifically accepted methodologies to be used in future NA automotive LCA studies.
4. In USEtox, a distinction was made between “recommended” and “interim” characterization factors (CFs), reflecting the level of reliability of the calculations in a qualitative way. All “Metals” have obtained “interim” CFs. Given the very high degree of uncertainty of “interim” CFs for metals (several orders of magnitude), USEtox “Human toxicity, cancer”, “Human toxicity, non-cancer” and “Ecotoxicity” results should not be used for decision making purposes in the automotive sector.
5. EPA/DOT Fuel economy and Environment Labels communicate two footprint information –Comparative Carbon and Smog footprints. These labels do not account for the combined impacts of the production and end of life stages of the vehicle which are expected to be significant for this product category. No clarification note is provided yet. These labels should be updated to meet ISO 14026\*), 6.9.Comparative footprint communications requirements to avoid any market distortion and to promote the dissemination of credible product information that is not misleading.

## **5.6 Benefits of Vehicle Electrification - GHG Emission of Vehicle Charging**

*Tugce Yuksel, Sabanci University, Turkey*

- Focus on CO<sub>2</sub>-emissions of marginal electricity generation in Turkey for charging electric vehicles
- CO<sub>2</sub> – emission from fuel combustion are covered and not based on LCA
- Conclusions and summary of findings:
  - Based on historical data dammed hydro and natural gas power plants to be the main marginal plants
  - MEFs in Turkey were found to be between 100 – 322 kg CO<sub>2</sub>/MWh
  - EVs are especially attractive for Turkey due to the lower MEFs
  - EVs would generate between one fifth and one third of the CO<sub>2</sub>-emissions produces by the same number of conventional vehicles (diesel and gasoline)

## **5.7 Life Cycle Analysis of a Modular Vehicle Concept: Insights in the Methodological Approach and Initial Results**

*Christian Ulrich, DLR, Germany*

- Methodology applied: ReCiPe (2016)
- Selected impact categories:
  - Acidification
  - Climate change
  - Eutrophication
  - GWP 100
  - Human toxicity
  - Mineral depletion
  - Particulate matter formation

## **5.8 Dynamic LCA for BEV Introduction and Development of Vehicle Fleet in Austria 2010 to 2050**

*Gerfried Jungmeier, JOANNEUM RESEARCH, Austria*

Conclusions on dynamic LCA development and application:

- Timing of environmental effects in LCA of EVs production-operation-end-of-life phases becomes relevant in the transition time of
  - strong BEV introduction in combination with a
  - strong increase of additional renewable electricity generation and
  - improvement of battery production technologies.



- Within the framework of LCA a methodology is developed and applied to the annual environmental effects of an increasing BEV fleet and substitution of ICE vehicles by considering the annual environmental effects of
  - New vehicle production
  - Supply of renewable electricity from existing and new power plant
  - Substituted operation of ICE vehicles and
  - End of life of old vehicles.
- „Climate Neutrality“ with addressing of limited GHG budget for Paris Agreement only possible on basis of dynamic LCA

### 5.9 Cradle to Grave Lifecycle GHG and Cost Analysis of Current and Future Light Duty Vehicles in the United States

*Jarod C. Kelly, Argonne National Laboratory, USA*

- Cradle-to-grave (C2G) analysis of current (2020) and future (2030 – 2035) of small and mid sized SUV vehicles is done using the GREET-model
- Focus on GHG emission and costs (levelized costs of driving - LCOD)
- Primary energy consumption not presented, but is part of the C2G analysis
- GREET does not include GHG emission (and any other impacts) from the construction of power plants e.g. wind, hydro and PV plants as they are not part of the fuel nor vehicle cycle in its baseline configuration, but it does cover these emissions and allows users to include those in analysis. It is generally ARGONNE’s view that these emissions are outside the system boundary
- Conclusions:
  - Deep decarbonisation requires more than powertrain technology alone
  - Technology advancement is an enabler, and more so for some powertrain than others (e.g. battery energy density improvements)
  - Biofuel, hydrogen pathways and electricity are all potential options
  - LCOD suggests that future advanced powertrains may cost less than conventional ICEV:
  - ICEV LCOD increases slightly
  - BEV decrease (200-mile range > ICEV)

### 5.10 TRACI\*): Current Status and Future Directions

*Jane Bare, EPA, USA*

*\*) Tool for the Reduction and Assessment of Chemical and other environmental Impacts*



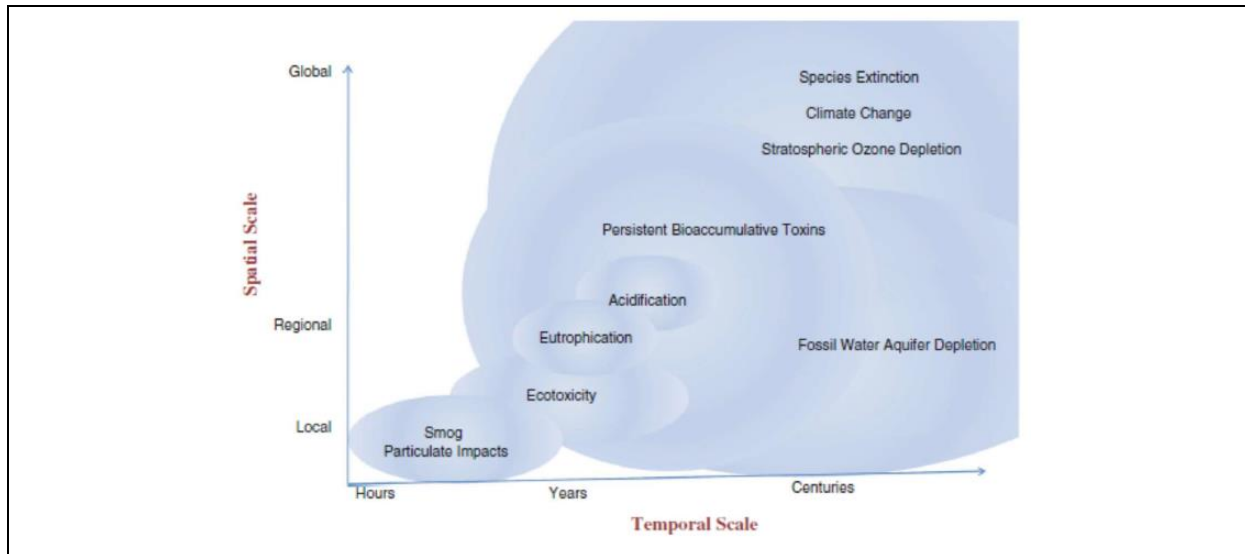

Examples of the temporal and spatial scale of selected environmental impacts.

- Selection of impact categories:
  - Ideally, LCA would include a comprehensive list of human and environmental impacts.
  - In reality, every LCA is limited by the resources, data, and models available.
- Midpoints vs. Endpoints: Midpoint analysis allows maximum comprehensiveness, scientific defensibility, minimal value choices, and fewer modeling assumptions.
- The level of certainty and global consensus for specific midpoint-level impact assessments vary based on the availability of data and models to support the impact assessment.

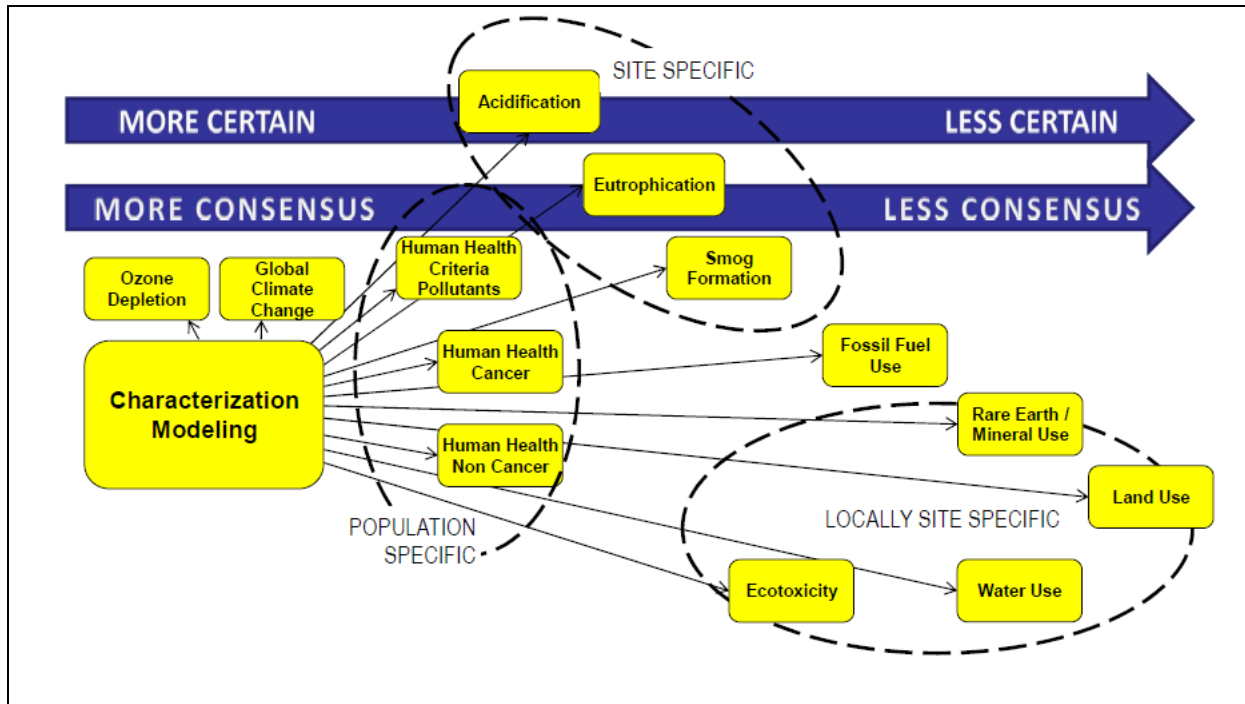

Midpoint level evaluations

- Comprehensive Impacts Considered: For electric vehicles, impacts may include:
  - Any issues specific to the electricity sources (e.g., coal, hydro, wind, nuclear) and alternative fuels (e.g., oil spills, land impacts),
  - Occupational health hazards (e.g., coal miner’s black lung disease),
  - Radioactive hazards (waste and nuclear power accidents),
  - Env. impacts (e.g., ecosystem disruption due to hydropower & wind),
  - Oil spills,
  - Earthquakes related to fracking or carbon sequestration,
  - End of life disposal issues, Occupational accidents (e.g., disabilities, fatalities), Noise and vibration impacts,
  - Fire and related injuries,
  - Impacts of water scarcity related to deep water aquifer depletion,
  - Numerous impacts to land use change and occupation,
  - Rare earth materials depletion,

- Fossil fuel depletion
- Human impacts or political unrest related to rare earth element distribution,
- Other endpoints/damages which are not included within the models?
- Which categories benefit from more spatially explicit characterisation factors (CFs) and why?
  - Some impact categories are the same no matter where the emissions (or resource use) occur (e.g., global climate change, ozone depletion - with the exception of altitude.)
  - Other highly detailed impact categories have many input parameters which are necessary for the calculation of very localized impacts (e.g., land use modifications may be dependent upon what soil type, slope of land, species of plants/animals, level of development). Many of these can be variable at a fine grid level.
  - Mid-level detailed impact categories such as acidification, eutrophication and smog formation require fate and transport calculations (and perhaps even background concentrations and buffering capacities) but not at as fine of level of detail.
- Can we do site specific modeling in LCA? - It depends.
  - For some impact categories like acidification, eutrophication, and smog formation we have a lot of experience and are able to simplify the models to make useful site-specific CFs.
  - For other impact categories like land use, the site specific models are best in models outside of LCA and it might take significant effort to convert into CFs. If these are important now, it may be best to use the current models.
- Human Health Modeling with USEtox:
  - USEtox, a UNEP SETAC Life Cycle Initiative consensus model, was initiated in 2003 and released in 2010.
  - International modelers compared model results of CalTOX, IMPACT 2002, USES-LCA, and EDIP97 for 76 substances which represented a variety of properties including volatility and toxicity.

- Developed in an EXCEL spreadsheet format with data for 3,500 substances including most of the substances on international lists like TRI.
- Includes interim characterization factors for inorganics and recommended or interim factors for organics.
- Development of TRACI
  - The intent of LCIA is to be as comprehensive as possible.
  - The selection of impact categories is a normative decision, which is informed by taxonomy.
  - The intent of TRACI is to be consistent with US policies, guidelines, practices, and perspectives while being true to the science and still practical.
  - Goal is to minimize value choices and assumptions that are incorporated into the methodology.
  - TRACI literature review began in 1995. Priority of inclusion of impact categories depended upon existing regulations and policies, perceived importance, and ease of modeling.
- Updating TRACI
  - Individual impact categories are evaluated and vetted within the Agency to see if advances in research should be adopted and/or if additional development is needed.
  - US EPA researchers are involved in international working groups to learn about other state-of-art advancements.
  - Regionalized characterization factors expected for selected impact categories.
  - Updated factors for:
    - Eutrophication.
    - Acidification.
    - Smog formation.
    - Human health.
- Summary:

- LCA can be a very useful tool in looking comprehensively at different impacts, different media, and at the various stages along the life cycle of a product or service.
- It is a developing field. Still need additional research especially in those areas that require site-specificity (e.g., land use). Or we need to support decision making with other tools.
- The incorporation of value choices and assumptions can be very non-transparent in some methodologies but some additional endpoint/damage modeling with well-informed uncertainty analysis may be useful.
- The goal and scoping phase is the most important step and it might be valuable to conduct a valuation workshop prior to selecting the impact categories.

### **5.11 Identification of key issues on Impact Assessment (interactive group work)**

#### **5.11.1 What do you think are the most appropriate impact categories and assessment methodologies for EVs environmental analysis?**

Contribution from participants:

- "Impact categories: I don't think the analyst should be choosing impact categories. I believe they should always provide a complete environmental footprint i.e. endpoint level analysis (and then explain the contributions to those endpoint results in terms of environmental problems and life cycle stages).
- Methodologies: Depends on your geographical context. In Quebec we use IMPACTWorld+. But in the case of EVs, there is a very political context to a ICE vs VE comparison as the electrification of the transport sector is seen as a way to reach carboneutrality goals. For this reason, consequential LCAs could be recommended (e.g. additional electricity power and energy required on the grids, international materials demand, ...)."
- GHG-emissions for the produced car and environmental and social impact of the needed raw materials, such as lithium, cobalt, nickel, copper, steel and aluminium
- "GWP, total primary energy demand and its shares, total material demand and its shares, amount and time of land occupation (incl. land type categories), climate neutrality index, material circularity index
- LCA is not the relevant methodology for biodiversity, eco-toxicity and human toxicity"
- GWP, ADP (CML), ETP (USETox), HTP (USETox)
- Carbon footprint, Resource dissipation (once proper methods will be available), toxicity impacts

- "As climate change constitutes the most pressing challenge of our time, the impact category "climate change" is of utmost significance. Moreover, since renewable energy sources are limited and will be needed in all major sectors to achieve our goals, the efficiency of fuel pathways plays a major role. To this end, in addition to "climate change", the impact category "cumulative energy demand" should be part of any holistic analysis. In addition, abiotic resources constitute a finite commodity, and some - especially metals - could see a rapid and continued grow in demand in the future. The consumption of resources should therefore also be a key point of emphasize of an LCA covering EVs.
- The question of assessment methodologies is largely dependent on the question your LCA should answer, so there is no definite answer. However, when assessing transport related product systems and especially EVs, the main environmental impacts will arise in different lifecycle stages, when compared with ICE-based vehicles. It is therefore crucial to analyse the whole product system "from Cradle to Grave" to achieve a maximum in comparability.
- For xEVs specifically GWP, CED, HTP/ETP, ARD and Water Scarcity. For assessment methodologies for end-of-life: hybrid approaches (e.g. also PEF circular footprint methodology), i.e. not just recycled content (1:0) or avoided burden (0:1) extremes, to ensure implications/benefits of end-of-life processing/choices are captured/incentivised, as well as encouraging the use of greater recycled materials in manufacturing. Consequential elements can be useful for some aspects, but due to uncertainties, perhaps better utilised in scenario analyses / complimented by energy system/fleet-level modelling to more effectively capture implications on finite (renewable energy-, bio-, or mineral-) resources.

### 5.11.2 In your opinion, which are the most relevant impacts to assess for comparing EVs and ICEs?

Contribution from participants:

- I don't think the analyst should be choosing impact categories. I believe they should always provide a complete environmental footprint i.e. endpoint level analysis (and then explain the contributions to those endpoint results in terms of environmental problems and life cycle stages).
- But maybe they could choose to study those impacts from a consequential perspective, given the political context to a ICE vs VE comparison (the electrification of the transport sector is seen as a way to reach carbon neutrality goals). For this reason, consequential LCAs could be recommended (e.g. additional electricity power and energy required on the grids, international materials demand, ...).
- grams GHGeqv/km
- GHG emissions, indicator for "Climate neutrality", NOx and PMx-emissions (from inventory analysis), primary energy demand (incl share of fossil energy) (e.g. energy efficiency index), circularity index based on material balance, land occupation
- GWP, CED, nrCED, POCP, ADP, ETP, HTP
- Carbon footprint, Resource dissipation (once proper methods will be available), toxicity impacts, biodiversity (when biofuels are included in the assessment)



- Here, too, it mainly depends on what question one is trying to answer when comparing EVs and ICEs. In general, in addition to "climate change", "primary energy demand" and "resource depletion" as key impact categories, road transport, especially in cities, is a key driver of the emission of particulate matter, which can have harmful effects on human health. Other airborne pollutants (SOx, NOx) play a major role and thus should also be investigated when assessing road transport.
- In addition to the above, for effective comparisons also with non-xEVs add also POCP, Particulate Matter Formation, Eutrophication Potential, Acidification Potential. Possibly also land use (depends on quality of data, particularly for biofuels).

### 5.11.3 Group 1: Selection of Impact Categories and Assessment Methodologies

Victor José Ferreira, IREC, ES

- Initial survey results and other discussion points
  - Provide a complete environmental footprint at endpoint level analysis (explaining the contribution to those endpoint results in terms of environmental problems and life cycle stages)
  - GWP, total primary energy demand and its shares, total material demand and its shares. Amount and time of occupation (land type of categories), climate neutrality index, material circularity index.
  - LCA is not relevant methodology for biodiversity, eco-toxicity and human toxicity
  - GHG-emissions for the produced car and environmental and social impact of the needed raw materials, such as Li, Co, Ni, Cu, Steel and Al
  - Consequential LCA instead of attributional for EVs evaluation

The summary of the group 1 work is shown in the following two tables (**GREEN: mostly agreed**; **RED: further development necessary**)

Environmental Categories and methodology for Evs			
ENVIRONMENTAL Categories	Unit (Methodology examples)	Discussion outputs	
Resource (material and energy) use	Abiotic depletion (elements)	kg Sb-eq (CML, midpoint)	These are properly to evaluate the environmental due to their maturity stage for easy understanding from EVs industrial sector
	Abiotic depletion (fossil)	MJ (CML, midpoint)	
	Primary energy	MJ (Primary energy non resources (net cal. Value midpoint)	
	Water use	m <sup>3</sup> (ReCiPe, midpoint), TRACI	
Emissions	Global Warming Potential	kg CO <sub>2</sub> -eq (CML, midpoint), TRACI	These are properly to evaluate the environmental due to their maturity stage for easy understanding from EVs industrial sector
	Acidification potential	kg SO <sub>2</sub> -eq (CML, midpoint), TRACI	
	Photochemical ozone creation potential	kg ethene-eq (CML, midpoint), TRACI	
	Eutrophication potential	kg PO <sub>4</sub> 3–eq (CML, midpoint), TRACI	
	Particulate matter	kg PM2.5 eq (ReCiPe, midpoint)	
	Smog formation	TRACI, midpoint	



Environmental Categories and methodology for Evs			
ENVIRONMENTAL Categories		Unit (Methodology examples)	Discussion outputs
Land use	Land use	m2 x yr annual crop land (Recipe, midpoint), TRACI	It is complicated to quantify in the models. Site specific issues bring difficult tfor the evaluation
			<p>This category is useful for the LCA research study (Academy)</p> <p>Keep the information as we can consider the updating for the next years</p>
Toxicity risk	Human toxicity potential – Cancer	CTUh (USEtox 2.01, midpoint), TRACI	It is complex. Site specific is very difficult to be addressed. It depends of the LCA purpose (aligned with the goal and scope). Maybe, in the future we will have new models to reflect the site specific issues
	Human toxicity potential – Non-Cancer	CTUh (USEtox 2.01, midpoint), TRACI	
	Fresh water aquatic ecotoxicity	kg-DCB-eq (CML, midpoint), TRACI	This category is useful for the LCA research study (Academy)
	Marine aquatic ecotoxicity	kg-DCB-eq (CML, midpoint), TRACI	Keep the information as we can consider the updating for the next years
	Terrestrial ecotoxicity	kg-DCB-eq (CML, midpoint), TRACI	
Protection areas	Hunan health Ecosystem health Resource availability	DALYs PDFm2yr MJ	They do not working in our approach since we are considering not consider midpoint to feel the endpoint indicators.

## 5.11.4 Group 2: Most Relevant Impacts for Comparing EVs and ICE

Jarod Cory Kelly, Argonne, USA

Summary of statements/comments of participants:

- GHG, CED, material requirement.
  - Focus on global impacts
  - Local impacts still relevant
  - Impacts beyond physics (social aspects, some skepticism) are outside LCA
  - Can LCA respond to the “S” in ESG
- Agreement on global impacts
- Local impacts may get mixed up (locationality (x-y, and z dim))
  - Clumping makes it less useful
  - PC comments on using in-take fractions (extent to which emissions are taken in by humans)
- Endpoints – tire emissions mixed with mg/km alongside exhaust emissions (size of PM issue (sort of), roadside emissions issue, mass/cubic meter)
- What are most important now?
  - GHG
  - CED
  - Primary energy (fossil and renewable shares)
  - Material intensity

- Resource depletion
  - Doesn't think that LCA is currently a good tool for this issue
  - Look at resource scarcity/criticality analysis (factor in together with LCA), can be factored into an EV world- think about material flow analysis (MFA): very relevant to recycling (coupled tool with LCA)
    - Seconded: many materials associated with mining processes that maybe neglected in the final LCA
    - ICEV uses more mtl in use phase, and BEV more in the production phase? Is there an increase in tradeable material (ores used in mtls used for batteries)
    - Expand the intersection of MFA and LCA
- GWP, primary energy, acidification pot., eutrophication pot., smog formation pot: traditional LCA impact cat. are well characterized
  - Cautious of expanding to other categories
  - BEV v. ICEV: the above cat are useful
  - Would like to see addition of water – how to assess correctly? (Scarcity, consumption, etc.)
    - Critique of Gabi software characterization of water (lumping together), how things are counted
    - ISO committees look at net loss of “water”, has it been polluted or not, includes scarcity
  - Skeptical of extending to other area b/c lose focus and controversial, not as confident in modeling
- Comparison between ICEV and EV
  - LCA comparisons are important, but focusing on decarbonizing that only focuses on powertrain is insufficient
    - Include modal (or vehicle down-size) shifts to provide more context in comparison
    - This can have a much greater impact
  - Built environment sets some limits
  - probably overestimating shared cars, ownership change of vehicles, how will things look for autonomous vehicles (suggests either increase or decrease, wide range of perspectives here)
  - haven't commented on the role of battery in the utility sector, how to use EV battery in the system (incentivize inclusion in utility management)

- Question about how to do “replacement” of vehicles or modal shifting
  - EVs have larger upfront burden
  - Fixation on urban dwellers
  - Exurban drive more km, might be better to focus on decarbonize
- Other impacts are very relevant
  - Things like noise (not in LCA)
  - Spatial occupation (infrastructure in general devoted vehicles)
  - Safety, could these be different between EV and ICEV
    - this is highly regulated and don't see how LCA could deal with
    - Thermal runaway, hydrogen issues, conventional has issues as well
    - Probably outside the scope b/c already highly regulated
- LCA should be a thing that directs us not a precise thing
  - Dynamic examination of hot spots
  - Avoid static-based evaluation (using today to comment on tomorrow without advancement in technology, etc.)
  - More of map than an endpoint

## 6 Task 30 “Assessment of Environmental Effects of Electric Vehicles”

**Members:** Austria, Canada, Germany, Spain, South Korea, Turkey, USA

Electric vehicles have the potential to substitute for conventional vehicles to contribute to the sustainable development of the transportation sector worldwide, for example, in the reduction of greenhouse gas (GHG) and particle emissions. There is international consensus that the improvement of the sustainability of electric vehicles can only be analyzed on the basis of life cycle assessment (LCA), which includes the production, operation, and the end-of-life treatment of the vehicles and the fuel cycle. All environmental impacts must include the whole value chain and - if relevant - interactions from recycling in the dismantling phase to the production phase, if recycled material is used to produce new vehicles.

The aim of Task 30 (2016 – 2021) is to analyze and assess environmental effects of electric vehicles (EVs) on water, land use, resources and air based on life cycle assessment in a cooperation of the participating countries in the International Energy Agency (IEA).

Task 30 is using the results of the completed Task 19 “Life Cycle Assessment of Electric Vehicles” (2011 – 2015, [www.ieahev.org/tasks/task-19-life-cycle-assessment-of-evs/](http://www.ieahev.org/tasks/task-19-life-cycle-assessment-of-evs/), led by JOANNEUM RESEARCH) as a foundation to subsequently examine the environmental effects – benefits and impacts - of vehicles with an electric drivetrain (EVs), based on life cycle assessment (LCA). With an eye on the three phases of LCA, such as production, operation and dismantling of EVs, various environmental effects of EVs on water, land use, resources and air, among others, will be analyzed and assessed. Thereby a strong accent is put on the comparison of environmental effects between pure battery EVs (BEV) and Plug-in hybrids (PHEVs) on one hand and conventional ICE vehicles using gasoline and diesel on the other side.

In recent years the focus in environmental assessments of electric vehicles was on global warming and primary energy consumption. But now it is recognized that other impacts gain additional relevance and must be addressed by life cycle based comparisons like water, land use, resource consumption, local PM and NO<sub>x</sub>-emissions. Therefore Task 30 will focus on following topics covering methodologies, data and case studies:

- Effects of EVs on water (emissions to water, waste water, “Water Footprint” of EVs)
- Effects on EVs on land use-resources-waste (land use, occupation and degradation, demand of renewable and fossil resources, recycling)
- Effects on EVs on air (local emissions and effects of NO<sub>x</sub>, PM and C<sub>x</sub>H<sub>y</sub>, human health effect and non-energy related emissions from tires and brakes)
- Overall environmental effects and their assessment (comparing and assessing different impact categories, single score methodologies, stakeholder involvement).

Within the Task, methodologies for helping countries implement EVs by identifying possibilities to maximize the environmental benefits will be developed. Besides, various case studies will be analyzed and networking combined with information exchange will be supported within the Task’s frames (Figure 1). The Task will proceed by holding a series of expert workshops addressing the following objectives:

- Methodologies on assessment of environmental effects
- Analyses of necessary and available data

- Overview of international studies/literature
- Analyses of current knowledge and future challenges
- Overview of key actors and stakeholders and their involvement
- Communication strategies to stakeholders
- Summarizing further R&D demand

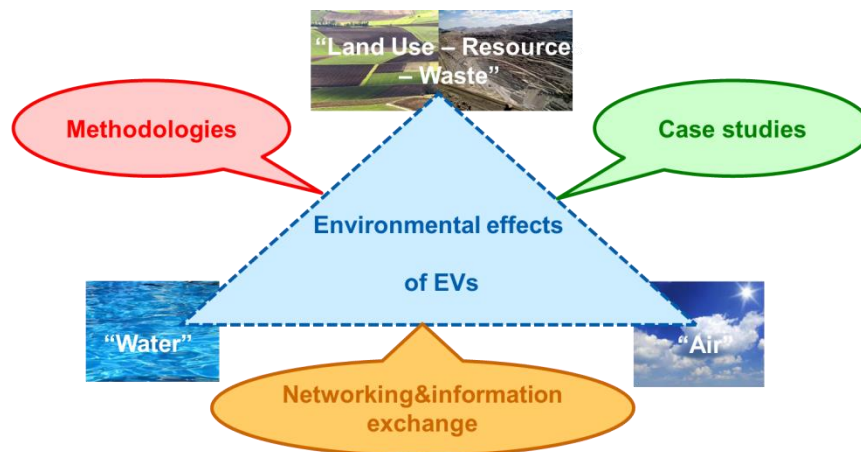

Figure 1: Working method in Task 30

Members in this Task will compile a list of environmental benefits and impacts of EVs with the goal to increase their overall acceptance by providing facts and figures on the environmental effects of EVs. Thus, numerous advantages of EVs compared to conventional vehicles will be shown. These results should help the industry and government to support further development and employment of EVs in all transport modes. The results will document and summarize the state of current knowledge and future challenges (incl. methodologies and case studies) on

- Effects of electric vehicles on water
- Effects of electric vehicles on Land use – resources – waste
- Effects of electric vehicles on air
- Overall environmental effects and their assessment of EVs
- R&D demand.

In addition to these technical and scientific results a glossary on “Frequently asked questions” (FAQ), a framework for Communication strategies to stakeholders and dissemination activities (e.g. proceedings, reports, papers, notes, presentations) will be available.

### Contact Details of the Operating Agents

For further information, please contact the Task 30 Operating Agent:

**Dr. Gerfried Jungmeier**

JOANNEUM RESEARCH Forschungsgesellschaft mbH

LIFE – Centre for Climate, Energy and Society

Waagner-Biro-Strasse 100

A-8020 Graz, Austria

[gerfried.jungmeier@joanneum.at](mailto:gerfried.jungmeier@joanneum.at)

+43 664 602 876 7630

**Dr. Víctor José Ferreira**

IREC – Catalonia Institute for Energy Research

Jardins de les Dones de Negre, 1 2<sup>a</sup>PI

Sant Adrià de Besòs 08930

[viferreira@irec.cat](mailto:viferreira@irec.cat)

+34 933 562 615

[www.ieahev.org/tasks/task-30-assessment-of-environmental-effects-of-electric-vehicles/](http://www.ieahev.org/tasks/task-30-assessment-of-environmental-effects-of-electric-vehicles/)